

IN THE UNITED STATES DISTRICT COURT
FOR THE WESTERN DISTRICT OF PENNSYLVANIA

DOGGIE DENTAL INC., and
PETER DERTSAKYAN,

Plaintiffs,

v.

CDOFFICE, ACGE LLC, AIKOPETS,
AOMETECH, AZOOCO CO.,
BIGSUPERMALL, BLAMCES
INNOVATION, BUDDY & BELLA,
BUNTHA.WINEE7098, BUYER'S
HAPPINESS, COLORFOR, COOLOH
BIKE, CRESPO STORE, CUTEBOOM,
DREAM ALLISON, ELLIARY-L,
ERICHOME, ET BBQ, EXOMART
(FORMERLY KNOWN AS TRIDENT
INCORPORATED), EYE SEE,
FIRELONG S. LTD, FOCUSES-USA,
FREYAMALL US, GARDENCOLO,
GIZHOME, HANY, HEALTHNEXUS,
HONG BANGZHUANGSHI ,
HOUZEMANN, HSNEYF, HUAI HUA
SHI ZHI YUAN MAO YI YOU XIAN
GONG SI, HUDUDU, IACROS,
IO.PRODUCTS, JI+, JUNE-MALL ,
JUSTIDEA88, KAIERCAT®, KANHAP,
KIDYBELL, KNY GLOBAL, KURILIN
STORE, LED PRO, LESANLI,
LIFEHACKR, LINZZE, LIPETY STORE,
LITTLE WORLD-US, LIVECREATIVE,
LKWXW , LOVELY PETS, LUCKY EGG
STORE, MAYII , MC ONE, MEL-MART,
MENNA PETS, MEWAJUMP
TECHNOLOGY, MIYHA, MOLANLY,
MUZII DIRECT, NARAKSPORT, NGOS,
NOOYI, NOTTODAY, OAKEN.OC9,
ORGEN, ORIGINAL STRENGTH,
PACIFIC-HOME , PAMLULU,
PNPCORP, PREP SELLERS, QOUYA
DIRECT, QP IMPORT SHOP,
RJSEMIFUN, ROYI, SDEER, SHERRY

Civil Action No.

FILED UNDER SEAL

MEI, SINGSKA, SMARTPET
(FORMERLY KNOWN AS QPQEQTQ),
SMOOTHEDO, SOAR COMPANY
LIMITED, SOLCLAIR, SONG YUAN,
SPLOVEUNIAA, SQUISHYLAND,
STAR PETS CO., START US, SUPER
STORE – SYMINGTON, TAKEBEST-
US, TALL SHOP, TIME4DEAL, TINY
FUN (FORMERLY KNOWN AS
SFYJUNHAO), TODAY'S DEALS
STORE, TOLOCO MAX , TRANS
GLOBAL, USAMS ORIGINAL, WAK-
US, WANKADA, WEIPUTEK,
WELLNESSPIC, WINSB,
WONDERFUL320, WOOWI0760 , XI
TING, YCL-US, YEEPEE, YSTECH,
ZCISSY, ZCXINW, ZERGSTORE,
ZISITA, ABEDOE DROPSHIPPING
STORE, ABEDOE ENERGETIC STORE,
ABEDOE FRANCHISED STORE,
ANIMAL ZONE STORE,
ARCTANGENT STORE, BETTERPET
STORE, BOLUX OFFICIAL STORE,
CHINELY STORE, CHONGLEGU
OFFICIAL STORE, CINDY
HOMEWARE STORE, COMFORTABLE
PETS HOUSE STORE, DAILY
GADGETS STORE, DAILY LIFE
HOUSE STORE, DO DROP SHIPPING
STORE, DOGBABY OFFICIAL STORE,
DREAMING LIFE STORE, DSRAY
STORE, DT STORE STORE,
EASYDREAM STORE, ETSREWO
STORE, FACEMASK FACTORY
STORE, FARM ASSISTANT STORE,
FIYDNDS STORE, GREEN HONEYPET
STORE, H&F STORE, HALASHOP
STORE, HANTAJANSS STORE,
HAPPYPET STORE, HEREHERE
STORE, HEYPET STORE, HOMEYARD
STORE, HTOP HOMELIVING STORE,
JANREE LIFE STORE, JAYHOME
STORE, JOYLIVE STORE, JOYLOVE
STORE, JUNEJOUR DIRECT STORE,
KATHLEENHOUSE0086 STORE,
KEMISIDI KEMISIDI STORE, KKM

5072153 STORE, LEAGUE OF PETS STORE, LEISURE AND HOLIDAYS STORE, LEMONBEST FRANCHISED STORE, LEMONBEST INTELLIGENT STORE, LHUANG ONLINE STORE, LIXING RETAIL STORE, LOVEPETS STORE, LYPET STORE, MGKPET GLOBAL STORE, MT HOMEWARE STORE, OVERSEAS DROPSHIPPING FACTORY STORE, PAWACA HOUSE STORE, PAWS UP STORE, PETCLOUD STORE, PETS HOMES STORE, QLUQ GARDEN STORE, SAB LOVES LIFE STORE, SHERGUT STORE, SHOP BEAUTIFUL LIFE STORE, SHOP09201996 STORE, SHOP4399105 STORE, SHOP5243276 STORE, SHOP5251291 STORE, SHOP5251295 STORE, SHOP5316019 STORE, SHOP5367212 STORE, SHOP5568062 STORE, SHOP5680040 STORE, SHOP5700129 STORE, SHOP5794112 STORE, S-I-M-P-L-E STORE, SMARTPET STORE, STRIKATE STORE, TIANXUAN03 STORE, TIEHO WARM HOUSE STORE, TOPFENG HARVEST STORE, ULTRASOUND PET DAVID STORE, ULTRASOUND PET MIMI STORE, ULTRASOUND PET OFFICIAL STORE, VOFORD OFFICIAL STORE, WARMING STORE, WEIXINBUY FRANCHISE STORE, WONDER FOR PETS STORE, XINLING STORE, XINLUHOME STORE, XINYOU STORE, YOCOMYLY 511511 STORE, YU2019 STORE, ZHANGYI HOMEGARDEN DECORATION STORE, ZLOOG OFFICIAL STORE, AJIESHOW, ALICEBABY678, ANNIE BABY STORE, BESTOPE, BIIGEOLED580, CAIJU TEMAI LUCKY, CHANGUSHOP, CHEETAHQIONG, CHENLIPINGSTORY, CHUNFUWANJUDIAN, CIELOSPORT, CLIX4129, COREY RAPPE, CY916, FANGMINGSO, FASHION TOOLS,

FENFENMEN, FENGNALIA, FU GUI
CONVENIENCE STORE,
FUZHOUYOUKENMAOYIYOUXIANG
ONGSI, GAOMEIJIAO2156,
GEGECOMPANY, GIFTENZA,
GLOBAL MTSHP, GLORIOUSSHOW,
GONGJIANGYANG, H877XOQPU,
HANNAMACE, HH_MANGO,
HONGXIHUALAPTOP, HUDALENG,
HZSDYOUTH23, IMIXEXPRESSIVE
FAITH, J83491860, JOSED02, LA
BOLEADA, LOVE FOR LIFE&SELF,
MAKE SHOPPING FUNNY AGAIN,
MILK BREAD, MING FASHION
STORE, MINGPINGMAIYI, MUMU913,
MYDEAL365, MYMIN2543, MZJH33,
NANTENGDA, NBOSOPPKSM,
NEWFIREPINLER, NINGHAI SUNRAY,
NISHGNEKAHGD, NXHIPNNER,
OUFUHENG, OVERLACKCAT,
PAMPERS, PANATIENDA, PANDITA,
PINAQZHAO70, QTWKGNUI, SAVE
YOUR DOLLARS, SDAGJK, SEA
EATING, SEEKNFIND, SEHBESTHAIR,
SELLINGFUN, SHENZHEN SHI SANDE
KEJI YOUXIAN GONGSI,
SHENZHENMINGSHUNXIN,
SHIZIHUIBAO, SHOPAUCTION,
SKKYY, SMART - KIDS JUICER,
SMARTPP, SOLARFLY, STALLINGS,
SUNEUISN2, TOAEON, TTKXTTXF,
UVSHOPPING, VENDING SHOPS, W5
FACTORY, WENVHGRTE10, WWD
FASHION STORE, XD FASHION
STORE, XIAOYESMILE, YDH789,
YIBLAKEJI, YKLESDEST88, ZEWOQ-
SHOP, ZRKKGM, ZUCCYOUTH0139,
ZX007, and
ZZ YIZE,

Defendants.

COMPLAINT FOR DAMAGES AND INJUNCTIVE RELIEF

Doggie Dental, Inc. (“Doggie Dental”), a California corporation, and Peter Dertsakyan (“Dertsakyan”), an individual (collectively, Doggie Dental and Dertsakyan are hereinafter referred to as “Plaintiffs”), hereby sue Defendants, the Individuals, Partnerships, and Unincorporated Associations identified in the Caption and which are set forth in **Schedule “A”** hereto (collectively “Defendants”). Defendants have willfully infringed one or more of the claims of U.S. Patent No. 10,477,838 (“Plaintiffs’ Patent” or “the ‘838 patent”) by offering for sale, selling, and distributing knock-off versions of Plaintiffs’ BRISTLY[®] dog toothbrush (“Infringing Products”). In support of their claims, Plaintiffs allege as follows:

NATURE OF THE ACTION

1. Dertsakyan is the inventor of the BRISTLY[®] dog toothbrush and the owner of intellectual property related thereto; Doggie Dental is the exclusive licensee of such intellectual property. In 2016 Dertsakyan developed the idea behind the BRISTLY[®] dog toothbrush. June 2017 saw the launch of the BRISTLY[®] dog toothbrush for beta testing. Over 50,000 dog owners experienced effortless daily tooth brushing of their dogs with BRISTLY. In early 2018, development and testing of a new version of the BRISTLY[®] dog toothbrush occurred. In June 2018 a crowdfunding campaign was launched on kickstarter.com. In less than two months, \$466,000 was raised with the assistance of nearly 11,000 backers and reached its funding goal in one day; the campaign was featured on the homepage of kickstarter.com as one of its successful campaigns. The crowdfunding campaign was continued on indiegogo.com where an additional \$534,000 was raised with the assistance of over 11,000 additional backers. The crowdfunding campaign for the BRISTLY[®] dog toothbrush is the campaign with the highest number of backers

and the highest amount raised of any pet campaigns. The new version of the BRISTLY[®] dog toothbrush went on sale in October 2018 (“Plaintiffs’ Product”).

2. Defendants have offered for sale, sold, and distributed knock-off versions of the Plaintiffs’ Product which closely mimic the appearance of Plaintiffs’ product and infringe at least one claim of the ‘838 patent. Moreover, Defendants’ sale, distribution, and advertising of the Infringing Product are highly likely to cause consumers to believe that Defendants are offering a genuine version of Plaintiffs’ Product when they are not.

3. Shown below are the six types of Infringing Product offered for sale by the Defendants:

Plaintiffs’ Product



Type 1 Infringing Product



Plaintiffs' Product



Type 2 Infringing Product



Plaintiffs' Product



Type 3 Infringing Product



Plaintiffs' Product



Type 4 Infringing Product



Plaintiffs' Product



Type 5 Infringing Product



Plaintiffs' Product



Type 6 Infringing Product



4. Defendants' actions have resulted in actual confusion in the marketplace between Defendants' Infringing Product and the genuine version of Plaintiffs' Product. Numerous purchasers of Defendants' Infringing Product have contacted Plaintiffs to complain about the performance of the Infringing Product believing same to be a genuine version of Plaintiffs' Product. Examples of such complaints include "my dog destroyed your teeth cleaning thing in 10 seconds" and "I was so worried my dog may have eaten parts of it that I had to check him over at the vet." Such complaints and negative comments are not just made directly to Plaintiffs,

but are also posted by members of the public on various websites and social media sites for all the world to see.

5. Defendants' Infringing Products are substantially inferior to the genuine product. Plaintiffs' Product is made of natural rubber. Defendants' Infringing Products are made with silicone or other materials. With poorly designed and manufactured products, Defendants' Infringing Products create serious public safety risks and threaten to destroy the reputation of high quality that Plaintiffs' Products have earned. A graphic illustration of the significant danger that the Infringing Products present to animals was brought to the Plaintiffs' attention by a pet owner who believed that Plaintiffs sold a faulty and defective product when in actuality the pet owner purchased a knock-off off masquerading as an authentic version of Plaintiffs' Product. The dog had chewed apart the fake product, swallowed a portion, and underwent corrective surgery to remove the piece. The pet owner provided the photographs below.

Infringing Product Chewed by Dog



Injured Dog After Surgery



The pet owner wanted Doggie Dental to pay for the damages caused by the fake product. Additionally, the pet owner has previously publicized this post on Doggie Dental's publicly available Facebook page:



Joyce Fazewski Bartlin DO NOT BUY!!!ALMOST KILLED MY DOG. BREAKS INTO PIECES BEFORE YOU NOTICE. MY DOG HAD SURGERY A WEEK LATER FOR AN OBSTRUCTION FROM THIS TOOTHBRUSH

Like · Reply · See Response · 1d



This pet owner’s experience and posting highlight both the actual confusion between the Infringing Products and the genuine version of Plaintiffs’ Product and the immediate and irreparable injury being incurred by the Plaintiffs.

6. Plaintiffs have taken numerous steps to protect the BRISTLY[®] dog toothbrush. Dertsakyan is the owner of U.S. Trademark Registration No. 5,815,298 for BRISTLY directed to “Non-medicated dental preparations for pets, namely, toothpaste and preparations for removing plaque; Home dental care products for dogs and cats, namely, toothpaste; Dental care and oral hygiene products for pets, namely, tooth cleaning preparations; Non-edible dental chews for pets; Non-medicated oral dental chews for dogs.” A copy of this registration attached hereto as **Exhibit 1**.

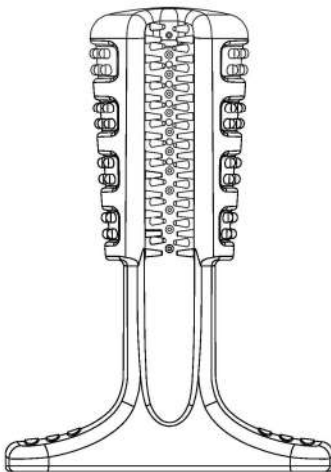
7. Dertsakyan is also the owner of U.S. Trademark Registration No. 5,844,832 for BRISTLY directed to “Toothbrushes for animals; Toothbrushes for pets; Home dental care products for dogs and cats, namely, toothbrush.” A copy of this registration attached as **Exhibit 2**.

8. Dertsakyan is the owner of U.S. copyright registration VA 2-122-455 directed to various photographs related to the BRISTLY[™] dog toothbrush (the “Plaintiffs’ Works”). A copy of Dertsakyan’s copyright registration certificate, together with copies of the deposit materials, is attached hereto as **Exhibit 3**. Dertsakyan is also the owner of unregistered copyrights related to the BRISTLY[®] dog toothbrush.

9. Dertsakyan is also the owner of various design patent applications directed to the BRISTLY[®] dog toothbrush, including an issued European Registered Community Design

(005818606-0001), an issued U.S. design patent D 901104, and a pending Chinese design patent application. A copy of Dertsakyan's Registered Community Design is attached hereto as

Exhibit 4. All of the design patent applications have common figures, and one of the figures is set forth below:



10. Dertsakyan is also the owner of U.S. Patent No. 10,477,838 for “Pet chew toy for dental self-cleaning by domestic pets,” which issued on November 19, 2019. A copy of the ‘838 patent is attached hereto as **Exhibit 5.**

11. On information and belief, Defendants’ sale of Infringing Products gives rise to a plausible expectation that discovery will reveal that Defendants’ actions all arise from the same transaction, occurrence, or series of transactions. Specifically, on information and belief, Defendants are actively participating in a conspiracy to distribute and sell Infringing Products. For example, Defendants, on information and belief, are working together to manufacture, arrange the manufacture of and/or sell and otherwise distribute the Infringing Products. Moreover, the Infringing Products all infringe on at least one claim of the Plaintiffs’ Patent and share similar characteristics including, for example, colors, shapes, and sizes.

12. Plaintiffs therefore bring this action for Patent Infringement under 35 U.S.C. § 271, and The All Writs Act, 28 U.S.C. § 1651(a).

JURISDICTION AND VENUE

13. This Court has subject matter jurisdiction over this action pursuant to 28 U.S.C. §§ 1331 and 1338.

14. This Court may exercise personal jurisdiction over a non-resident of the State in which the Court sits to the extent authorized by the state's laws. Fed. R. Civ. P. 4(e). Pennsylvania authorizes personal jurisdiction over each Defendant pursuant to 42 Pa. Cons. Stat. § 5322 (a) which provides in pertinent part: “A tribunal of this Commonwealth may exercise personal jurisdiction over a person ... as to a cause of action or other matter arising from such person: (1) Transacting any business in this Commonwealth. Without excluding other acts which may constitute transacting business for the purpose of this paragraph: (ii) The doing of a single act in this Commonwealth for the purpose of thereby realizing pecuniary benefit ... (3) Causing harm or tortious injury by an act or omission in this Commonwealth. (4) Causing harm or tortious injury by an act or omission outside this Commonwealth ... (10) Committing any violation within the jurisdiction of the Commonwealth of any statute, home rule charter, local ordinance or resolution, or rule or regulation promulgated thereunder by any government unit or of any order of court or other government unit.” In the alternative, Federal Rule of Civil Procedure 4(k) confers personal jurisdiction over the Defendants because, upon information and belief, Defendants regularly conduct, transact and/or solicit business in Pennsylvania and in this judicial district, and/or derive substantial revenue from their business transactions in Pennsylvania and in this judicial district and/or otherwise avail themselves of the privileges and protections of the laws of the Commonwealth of Pennsylvania such that this Court's assertion of

jurisdiction over Defendants does not offend traditional notions of fair play and due process, and/or Defendants' illegal counterfeiting and infringing actions caused injury to Plaintiffs in Pennsylvania and in this judicial district such that Defendants should reasonably expect such actions to have consequences in Pennsylvania and in this judicial district, for example:

a. Upon information and belief, at all times relevant hereto, Defendants were and/or are systematically directing and/or targeting their business activities at consumers in the United States, including Pennsylvania, through on-line platforms with Merchant Storefronts (as defined *infra*), via on-line marketplace websites, such as Amazon.com, under the Seller IDs, as well as any and all as yet undiscovered accounts with Merchant Storefronts held by or associated with Defendants, their respective officers, employees, agents, servants and all persons in active concert or participation with any of them ("User Accounts"), through which consumers in the United States, including Pennsylvania, can view the one or more of Defendants' Merchant Storefronts that each Defendant operates, uses to communicate with Defendants regarding their listings for Infringing Products and to place orders for, receive invoices for and purchase Infringing Products for delivery in the U.S., including Pennsylvania, as a means for establishing regular business with the U.S., including Pennsylvania.

b. Upon information and belief, certain Defendants are sophisticated sellers, each operating one or more commercial businesses using their respective User Accounts through which Defendants, their respective officers, employees, agents, servants and all persons in active concert of participation with any of them, operate storefronts to manufacture, import, export, advertise, market, promote, distribute, offer for sale and/or otherwise deal in products, including the Infringing Products, which are held by or

associated with Defendants, their respective officers, employees, agents, servants and all persons in active concert or participation with any of them (“Merchant Storefront(s)”) in wholesale quantities at significantly below-market prices to consumers worldwide, including to those in the U.S., and specifically Pennsylvania.

c. Upon information and belief, Defendants’ Merchant Storefronts reflect multiple sales to consumers all over the world, including repeat sales to consumers in the U.S. and into this judicial district.

d. Upon information and belief, all Defendants accept payment in U.S. Dollars and offer shipping to the U.S., including to Pennsylvania.

e. Upon information and belief, at all times relevant, Defendants have transacted business with consumers located in the U.S., including Pennsylvania, for the sale and shipment of Infringing Products.

f. Upon information and belief, Defendants are employing and benefiting from substantially similar, paid advertising and marketing and advertising strategies in order to make their Merchant Storefronts selling illegal goods appear more relevant and attractive to search result software across an array of search words, including but not limited to “BRISTLY”, and “WORLD’S MOST EFFECTIVE DOG TOOTHBRUSH”. By their actions, Defendants are causing concurrent and indivisible harm to Plaintiffs and the consuming public by (i) depriving Plaintiffs of their right to fairly compete for space within the various on-line marketplace search results and reducing the visibility of the Plaintiffs’ Product on various on-line marketplaces and/or diluting and driving down the retail market price for the Plaintiffs’ Product (ii) causing an overall degradation of the value of the goodwill associated with Plaintiffs’ Marks and Plaintiffs’ Product; and (iii)

increasing Plaintiffs' overall cost to market its goods and educate consumers about its brand and products.

g. Upon information and belief, Defendants have cooperated, communicated their plans with one another, shared information, and coordinated their efforts, all in order to create an illegal marketplace operating in parallel to the legitimate marketplace of Plaintiffs' and the legally authorized resellers of Plaintiffs' genuine goods.

h. Upon information and belief, Defendants are concurrently targeting their infringing activities toward consumers and causing harm in Allegheny County, Pennsylvania.

i. Upon information and belief, Defendants likely reside and/or operate in foreign jurisdictions with lax trademark and patent enforcement systems and are cooperating by creating an illegal stream of infringing and counterfeit goods.

j. Upon information and belief, Defendants are aware of Plaintiffs, their genuine BRISTLY[®] dog toothbrush product, and are aware that their illegal infringing actions alleged herein are likely to cause injury to Plaintiffs in the United States, in Pennsylvania and in this judicial district specifically, as Plaintiffs conducts substantial business in Pennsylvania.

k. Plaintiffs are suffering irreparable and indivisible injury and suffered substantial damages as a result of Defendants' unauthorized and wrongful sale of counterfeit and infringing goods.

15. Venue is proper, *inter alia*, pursuant to 28 U.S.C. § 1391 because, for example:

a. Upon information and belief, Defendants conduct, transact, and/or solicit business in this judicial district.

b. Upon information and belief, Defendants or their agent(s) may be found in this district because personal jurisdiction is proper in this district.

c. Upon information and belief, this is a judicial district in which a substantial part of the events or omissions giving rise to the infringement claims occurred, or a substantial part of the property that is the subject of the action is situated.

d. Defendants not resident in the United States may be sued in this judicial district because personal jurisdiction is proper in this district.

THE PLAINTIFFS

16. Plaintiff Doggie Dental, Inc., is a California corporation has a mailing address of 827 Hollywood Way #465, Burbank, California 91505. Doggie Dental is the exclusive licensee of the intellectual property relating to the BRISTLY[®] dog toothbrush.

17. Plaintiff Peter Dertsakyan a/k/a Petros Dertsakyan, is an individual who resides in California and has a mailing address of 827 Hollywood Way #465, Burbank, California 91505. Dertsakyan is the inventor of the BRISTLY[®] dog toothbrush and the owner of the intellectual property relating thereto.

18. Doggie Dental is, in part, engaged in the business of manufacturing and distributing throughout the world, including within this district, the BRISTLY[®] dog toothbrush, through its website, bristly.com, its authorized seller on amazon.com, and various retail establishments, including Petsense. Defendants, through the sale and offer to sell Infringing Products are

directly, and unfairly, competing with Plaintiffs' economic interest in the Commonwealth of Pennsylvania and causing Plaintiffs harm within this jurisdiction.

19. Like many other brand owners, Plaintiffs suffer ongoing daily and sustained violations of their rights at the hands of infringers, such as Defendants herein, who wrongfully reproduce Plaintiffs' Products for the twin purposes of (i) duping and confusing the consuming public and (ii) earning substantial profits from the sale of their Infringing Products. The natural and intended byproduct of Defendants' actions is the erosion and destruction of the goodwill associated with Plaintiff's Products and the destruction of the legitimate market sector in which Plaintiffs operate.

20. The recent explosion of counterfeiting and infringement over the Internet, including through online marketplace platforms, has created an environment that requires brand owners, such as Plaintiffs, to expend significant time and money across a wide spectrum of efforts in order to protect both consumers and Plaintiffs from the ill effects of confusion and the erosion of the goodwill associated with Plaintiffs' brand and products.

THE DEFENDANTS

21. The Defendants are individuals and/or business entities of unknown makeup, each of whom, upon information and belief, either reside or operate in foreign jurisdictions, or redistribute products from the same or similar sources in those locations. Defendants have the capacity to be sued pursuant to Federal Rule of Civil Procedure 17(b). Defendants target their business activities toward consumers throughout the United States, including within this district, and conduct pervasive business through the operation of, at least, one fully interactive commercial Internet based e-commerce store via, at least, the Internet based online marketplaces Amazon.com, ebay.com, aliexpress.com, and wish.com, all under the Seller IDs.

22. Upon information and belief, the Defendants use aliases in conjunction with the operation of their businesses as set forth in **Schedule “A”** hereto.

23. Defendants are the past and present controlling forces behind the sale of products infringing at least one claim of the ‘838 patent described herein using at least the Seller IDs.

24. Upon information and belief, Defendants directly engage in unfair competition with Plaintiffs and their authorized resellers by willfully advertising, offering for sale and selling goods infringing upon at least one claim of the ‘838 patent to consumers within the United States and this district through several fully interactive, commercial Internet websites and Internet based e-commerce stores operating under, at least, the storefronts, the Seller IDs, and any additional domain names, websites and corresponding website URLs or seller identifications and store URL aliases not yet known to Plaintiffs. Defendants have purposefully directed some portion of their illegal activities towards consumers in the Commonwealth of Pennsylvania through the advertisement, offer to sell, sale, and/or shipment of Infringing Products into the Commonwealth.

25. Defendants have registered, established or purchased, and maintained the on-line marketplace website storefronts and Seller IDs. Upon information and belief, Defendants have engaged in fraudulent conduct with respect to the registration of the storefronts and Seller IDs by providing false and/or misleading information to the Internet based e-commerce platforms where they offer for sale and/or sell, during the registration or maintenance process related to their respective Seller ID. Upon information and belief, Defendants have anonymously registered and maintained some of the Seller IDs for the sole purpose of engaging in illegal infringing activities.

26. Upon information and belief, Defendants will continue to register or acquire new seller identification aliases for the purpose of selling and offering for sale goods infringing at least one claim of the '838 patent unless preliminarily and permanently enjoined.

27. Defendants' Internet-based businesses amount to nothing more than illegal operations established and operated in order to infringe the intellectual property rights of Plaintiffs.

28. Defendants' business names, i.e., the Seller IDs, associated payment accounts, and any other alias seller identification names used in connection with the sale of goods infringing on at least one claim of the '838 patent are essential components of Defendants' online activities and are the means by which Defendants further their infringement scheme and cause harm to Plaintiffs.

COMMON FACTUAL ALLEGATIONS

Plaintiffs and Their BRISTLY Dog Toothbrush

29. Plaintiffs developed and sell a unique and revolutionary product under their registered trademark BRISTLY® ("Plaintiffs' Mark") that safely and easily permits dogs to brush their own teeth removing plaque and tarter ("Plaintiffs' Product"). Plaintiffs identified the need for this product and created the market for this product. Below is an image of one of Plaintiffs' Products, which retails for \$16.99:



The Plaintiffs' Mark is inherently distinctive, as recognized by the U.S. Patent and Trademark Office in issuing two trademark registrations on the Principal Register.

30. Plaintiffs' On November 19, 2019, the U.S. Patent and Trademark Office issued the '838 patent, the claims of which protect Plaintiffs' Product. The '838 patent has never been assigned or licensed to any of the Defendants in this matter. Plaintiffs have provided constructive notice of the '838 patent by placing the patent number of the '838 patent on the packaging of Plaintiffs' Product.

31. Plaintiffs' Bristly product has been featured in videos or articles by numerous media outlets, including MSN (<https://www.msn.com/en-sg/lifestyle/lifestylegeneral/a-new-chew-toy-will-help-your-dog-brush-its-own-teeth/ar-AAA8pvh>), Pet Lover Geek (<https://www.facebook.com/petlovergeek/videos/613996128985404>), Askmen (https://www.askmen.com/entertainment/guy_gear/best-new-kickstarters-for-june-28-2018.html), Interesting Engineering (<https://interestingengineering.com/this-chew-stick-for-dogs-helps-them-achieve-good-oral-health>), Awesome Stuff 365 (<https://awesomestuff365.com/bristly-toothbrush-for-dogs/>), star2.com (<https://www.star2.com/living/2018/07/28/toothbrushing-stick-dogs-clean-teeth/>), Dude (<http://www.dudeiwantthat.com/household/pets/bristly-toothbrush-for-dogs.asp>), Gaget flow (<https://thegadgetflow.com/blog/bristly-is-the-chew-toy-that-cleans-your-dogs-teeth/> and <https://thegadgetflow.com/portfolio/dog-tooth-brushing-stick/>), The Gadgeteer (<https://thegadgeteer.com/2018/07/20/micro-veggie-growing-tray-tiny-edc-pen-a-toothbrush-for-dogs-and-more-notable-crowdfunding-campaigns/>), Steemit (<https://steemit.com/steemhunt/@adarshagni/bristly-chew-stick-for-dogs>), New Atlas (<https://newatlas.com/bristly-dog-toothbrush/55401/>), TheThings.com

(<https://www.thethings.com/chew-toy-helps-dogs-brush-teeth>), slashpets
(<https://www.slashpets.com/bristly-toothbrush/>), Cool Business Ideas
(<https://www.coolbusinessideas.com/archives/toothbrush-for-your-doggy/>), Cool Hunting
(<https://coolhunting.com/design/bristly-dog-toothbrush/>), MNN
(<https://www.mnn.com/family/pets/stories/answer-dog-toothbrushing-struggle>), Gismo Review
(<https://www.gismoreview.com/bristly-the-toothbrush-for-dog/>), Product Watch
(<https://productwatch.co/hate-brushing-your-dogs-teeth-meet-bristly-and-forget-your-tribbles/>),
Mental Floss (<http://mentalfloss.com/article/551054/new-chew-toy-will-help-your-dog-brush-its-own-teeth>), and Trend Hunter (<https://www.trendhunter.com/trends/bristly>).

Defendants' Wrongful and Infringing Conduct

32. Upon information and belief, Defendants are, through at least the Internet based e-commerce stores operating under the Seller IDs, promoting, selling, offering for sale and distributing goods that willfully infringe at least one claim of the '838 patent while marketing their knock-off products in a willful attempt to pass off their knock-off products as the genuine version of Plaintiffs' Products.

33. Upon information and belief, Defendants' Infringing Products are of a quality substantially and materially different than that of Plaintiffs' genuine goods. Defendants, upon information and belief, are actively using, promoting and otherwise advertising, distributing, selling, and/or offering for sale substantial quantities of their Infringing Products with the knowledge and intent that such goods will be mistaken for the genuine high quality goods offered for sale by Plaintiffs despite Defendants' knowledge that they are without authority to use the subject matter of the '838 patent.

34. Defendants advertise their Infringing Products for sale to the consuming public via Internet based e-commerce stores on, at least, one Internet marketplace using at least the Seller IDs. In so advertising these goods, Defendants improperly and unlawfully infringe at least one claim of the '838 patent without Plaintiffs' permission.

35. As part of their overall infringement and counterfeiting scheme, Defendants are, upon information and belief, concurrently employing and benefitting from substantially similar, advertising and marketing strategies based, in large measure, upon an illegal use of infringements of the '838 patent in order to make their e-commerce stores selling illegal goods appear more relevant and attractive to consumers online. By their actions, Defendants are contributing to the creation and maintenance of an illegal marketplace operating in parallel to the legitimate marketplace for Plaintiffs' genuine goods. Defendants are causing, individual, concurrent and indivisible harm to Plaintiffs and the consuming public by (i) depriving Plaintiffs and other third parties of their right to fairly compete for space within search engine results and reducing the visibility of Plaintiffs' genuine goods on the World Wide Web, (ii) causing actual consumer confusion, (iii) harm to Plaintiffs' reputations, including tarnishing their status as the innovator in this market, (iv) an overall degradation of the value of the goodwill associated with the Plaintiffs' brand, and (v) increasing Plaintiffs' overall cost to market its goods and educate consumers about its brand via the Internet.

36. Plaintiffs confirmed that Defendants were and/or are still currently offering for sale and/or selling Infringing Products for sale to the consuming public via Internet based e-commerce stores on, at least, one Internet marketplace using at least the Seller IDs and that Defendants provide shipping and/or have actually shipped Infringing Products to customers located within this judicial district.

37. There is no question that the Infringing Product itself and the manner in which it is marketed is designed to confuse and mislead consumers into believing that they are purchasing Plaintiffs' Product or that the Infringing Product is otherwise approved by or sourced from Plaintiffs, thereby trading on the goodwill and reputation of Plaintiffs.

38. Upon information and belief, at all times relevant hereto, Defendants in this action had full knowledge of Plaintiffs' ownership of the '838 patent. Defendants' use of the '838 patent is without Plaintiffs' consent or authorization.

39. Defendants are engaging in the above-described illegal infringing activities knowingly and intentionally or with reckless disregard or willful blindness to Plaintiffs' rights for the purpose of infringing the '838 patent and trading on Plaintiffs' goodwill and reputation. If Defendants' intentional infringing activities are not preliminarily and permanently enjoined by this Court, Plaintiffs and the consuming public will continue to be harmed.

40. Defendants' above identified infringing activities are likely to cause confusion, deception, and mistake in the minds of consumers before, during, and after the time of purchase. Moreover, Defendants' wrongful conduct is likely to create a false impression and deceive customers, the public, and the trade into believing there is a connection or association between Plaintiffs' Products and Defendants' Infringing Products, which there is not.

41. Upon information and belief, Defendants' payment and financial accounts are being used by Defendants to accept, receive, and deposit profits from Defendants' infringing and unfairly competitive activities connected to their Seller IDs and any other alias e-commerce stores, photo albums, seller identification names, domain names, or websites being used and/or controlled by them.

42. Further, upon information and belief, Defendants are likely to transfer or secret their assets to avoid payment of any monetary judgment awarded to Plaintiffs.

43. Plaintiffs have no adequate remedy at law.

44. Plaintiffs are suffering irreparable injury and have suffered substantial damages as a result of Defendants' unauthorized and wrongful infringement of at least one claim of the '838 patent. If Defendants' infringing activities are not preliminarily and permanently enjoined by this Court, Plaintiffs and the consuming public will continue to be harmed.

45. The harm and damages sustained by Plaintiffs have been directly and proximately caused by Defendants' wrongful reproduction, use, advertisement, promotion, offers to sell, and sale of their Infringing Products.

COUNT I – PATENT INFRINGEMENT (35 U.S.C. § 271 (a))

46. Plaintiffs hereby adopt and re-allege the allegations set forth in the preceding paragraphs as if set forth herein.

47. Plaintiffs are the owner of U.S. Patent No. 10,477,838 B2 (“the ‘838 Patent”), issued November 19, 2019, for “PET CHEW TOY FOR DENTAL SELF-CLEANING BY DOMESTIC PETS” and which covers Plaintiffs' Product. A true and correct copy of which is attached as **Exhibit 5**.

48. The Accused Type 1-6 Products infringe at least Claim 1 of the '838 patent, as more fully detailed in **Exhibits 6-11**, respectively.

49. Defendants have infringed and continue to infringe the '838 patent either directly or indirectly through acts of contributory infringement or inducement in violation of 35 U.S.C. §

271, by making, using, selling, importing and/or offering to sell Infringing Products, namely the pet toothbrushes that are nearly identical to Plaintiffs' Product.

50. Defendants' infringement, contributory infringement and/or inducement to infringe has injured Plaintiffs and they, therefore, is entitled to recover damages adequate to compensate it for such infringement, but in no event less than a reasonable royalty.

51. Defendants' infringement, contributory infringement and/or inducement to infringe has been willful and deliberate because Defendants have notice of or knew of the '838 patent and have nonetheless injured and will continue to injure Plaintiff, unless and until this Court enters an injunction, which prohibits further infringement and specifically enjoins further manufacture, use, sale, importation and/or offer for sale of products or services that come within the scope of the '838 patent.

52. Based on Defendants' wrongful conduct, Plaintiff is entitled to injunctive relief as well as monetary damages and other remedies as provided by the Patent Act, including damages that Plaintiff has sustained and will sustain as a result of Defendants' illegal and infringing actions as alleged herein, enhanced discretionary damages and reasonable attorneys' fees and costs.

PRAYER FOR RELIEF

WHEREFORE, Plaintiffs demands judgment on all Counts of this Complaint and an award of equitable relief and monetary relief against Defendants as follows:

a. Entry of temporary, preliminary and permanent injunctions pursuant to 35 U.S.C. § 283, and Federal Rule of Civil Procedure 65 enjoining Defendants, their agents, representatives, servants, employees, and all those acting in concert or participation therewith, from

manufacturing or causing to be manufactured, importing, advertising or promoting, distributing, selling or offering to sell their Infringing Products;

c. Entry of an Order that, upon Plaintiffs' request, any Internet marketplace website operators and/or administrators that are provided with notice of the injunction, including but not limited to the online marketplaces hosted by Amazon.com, eBay.com, Aliexpress.com, and Context Logic, Inc. d/b/a wish.com, identify any e-mail address known to be associated with Defendants' respective Seller ID, and cease facilitating access to any or all e-commerce stores through which Defendants engage in the promotion, offering for sale, and/or sale of Infringing Products.

d. Entry of an Order that, upon Plaintiffs' request, any Internet marketplace website operators and/or administrators who are provided with notice of the injunction, including but not limited to online marketplaces hosted by Amazon.com, eBay.com, Aliexpress.com, and Context Logic, Inc. d/b/a wish.com permanently remove any and all listings offering for sale Infringing Products via the e-commerce stores operating under the Seller IDs, including any and all listings linked to the same seller or linked to any other alias seller identification name being used and/or controlled by Defendants to promote, offer for sale and/or sell Infringing Products.

e. Entry of an Order that, upon Plaintiffs' request, any Internet marketplace website operators and/or administrators who are provided with notice of the injunction, including but not limited to online marketplaces hosted by at least one of Amazon.com, eBay.com, Aliexpress.com, and Context Logic, Inc. d/b/a wish.com, immediately cease fulfillment of and sequester all goods of each Defendant or other Seller under a Seller ID offering for sale the Infringing Product in its inventory, possession, custody, or control, and surrender those goods to Plaintiffs.

f. Entry of an order awarding Plaintiffs damages adequate to compensate for the infringement of its patent, but in no event less than a reasonable royalty for the use made of the invention by the Defendants, together with interest and costs as fixed by the Court pursuant to 35 U.S.C. § 284 and that the award be trebled as provided for under 35 U.S.C. §284.

g. Entry of an Order finding that this case is exceptional and an award to Plaintiffs of its attorney fees and costs as provided by for under 35 U.S.C. § 285.

h. Entry of an Order that, upon Plaintiffs' request, any financial institutions, payment processors, banks, escrow services, money transmitters, or marketplace platforms, including but not limited to, Zhejiang Ant Small and Micro Financial Services Group Co., Ltd. AliPay (China) Internet Technology Co. Ltd., and Alipay.com Co., Ltd. (collectively referred to as "AliPay")¹, Amazon Payments, Inc., PayPal, Inc. d/b/a paypal.com, and Context Logic, Inc. d/b/a wish.com, or marketplace platforms, including but not limited to, Amazon.com, ebay.com, aliexpress.com, and Context Logic, Inc d/b/a wish.com, and their related companies and affiliates, identify and restrain all funds, up to and including the total amount of judgment, in all financial accounts and/or sub-accounts used in connection with the Seller IDs or other domain names, alias seller identification names, or e-commerce store names or store URLs used by Defendants presently or in the future, as well as any other related accounts of the same customer(s) and any other accounts which transfer funds into the same financial institution account(s), to be surrendered to Plaintiffs in partial satisfaction of the monetary judgment entered herein.

i. Entry of an award of pre- and post-judgment interest on the judgment amount.

¹ WorldPay US, Inc. ("WorldPay") processes transactions on behalf of Alibaba and Alipay, which may appear as "Aliexpress" on a cardholder's credit card statement.

j. Entry of an order for any further relief as the Court may deem just and proper.

DEMAND FOR JURY TRIAL

Plaintiffs respectfully demand a trial by jury on all claims.

Respectfully submitted,

February 25, 2021

/s/ Stanley D. Ference III

Stanley D. Ference III

Pa. ID No. 59899

courts@ferencelaw.com

Brian Samuel Malkin

Pa. ID No. 70448

bmalkin@ferencelaw.com

FERENCE & ASSOCIATES LLC

409 Broad Street

Pittsburgh, Pennsylvania 15143

(412) 741-8400 - Telephone

(412) 741-9292 - Facsimile

Attorneys for Plaintiffs

Doggie Dental, Inc. and

Peter Dertsakyan

Schedule “A”
Defendants With Store Name and Seller ID

Defendant No.	Store Name	Seller ID
1	CDOFFICE	A2HXCKS2AV7XY3
2	ACGE LLC	A1BKKTQIKG0Q1B
3	AikoPets	A2M36Z0WA1TNMA
4	AomeTech	AJ5KGWPO1ZJP6
5	Azooco Co.	A1O7E2VP3WKO5T
6	Bigsupermall	AZBBFPJUQ1X5P
7	Blamces innovation	A20RRMVQSEBION
8	Buddy & Bella	AP87H0LBW6ANU
9	Buntha.winee7098	A2P7HKPXZ86JGM
10	Buyer's Happiness	A36AW7PWD83LJO
11	Colorfor	A2E9631H7LXS19

12	Cooloh Bike	A2EFMTFHX7SHZ8
13	Crespo store	ANIGTDIU94MQJ
14	Cuteboom	AO4DRR9OW5IW3
15	Dream Allison	A3L05QW1K3Z4G2
16	Ellinary-L	A24J7S9IW08C0W
17	Erichome	A1G3TRH46Z9DNM
18	ET BBQ	A1EQ7KZKHOU0FF
19	ExoMart (Formerly Known As Trident Incorporated)	AWFILDA9GR8EJ
20	Eye see	A2R4QSOM0GN8MP
21	Firelong S. Ltd	A1XC6YUUHFOOER
22	Focuses-USA	A1NIV3RVE2CVSZ
23	Freyamall US	A2C9WB9G49X2M3
24	Gizhome	A3EQWXS3T1RKI
25	HANY	A1Q3HM0IW8DRWS
26	healthnexus	A3DQZWP4ZMBLDB

27	hong bangzhuangshi	A2NSJW1EFUROOE
28	Houzemann	A3TRBQSQHPBJLR
29	HSNEYF	A1TIJ72TNNFTCQ
30	huai hua shi zhi yuan mao yi you xian gong si	AOKYVXXZ9D2G3
31	HUDUDU	A3AGCMKNL8JYH8
32	iAcros	A27WHABR7AW05V
33	IO.Products	A37VBGZ52HT94
34	JI+	A14QKGO0YYJFU3
35	June-mall	A180WI6RJABFBE
36	JUSTIDEA88	A1WZ2466W8SDA5
37	Kaiercat®	A15RNIB7Q8W7KU
38	kanhap	A3ENRCMFU8KOHC
39	KIDYBELL	A7C19INY0C10K
40	KNY Global	A4PE0YIU2AQ05
41	Kurilin Store	A3THKZPKKBDSZ9

42	LED Pro	A1T8OC4PUSA4W
43	LESANLI	A7JGX5H7MCPYB
44	Lifehackr	A2R11B235CDHSW
45	Linzze	A3E65FQZ8ST8KT
46	LIPETY Store	A35GGQ2DSQXORQ
47	Little World-US	A3ENZ260X3A00C
48	LiveCreative	A2XRB451VK224M
49	LKwxw	A3MW9GZDA7Y04W
50	Lovely Pets	A1OP7QLWWPVI8R
51	Lucky Egg Store	A1SSUBEAKOBA9F
52	MaYii	A113KDYJJ9EE95
53	Mc One	A1WL6UPZIK4MD0
54	Mel-Mart	A26GP9M2HNYK3V
55	Menna Pets	A2TXAGO012HA5Y
56	Mewajump Technology	A2UBRE946Z6VKI
57	Miyha	A3VJO6QDJD6C4U

58	MOLANLY	A3NNKZ0BUYXWV2
59	Muzii Direct	A14MB4USO4XU9T
60	narakSPORT	A26UJ9L8PVPDPO
61	NGOS	A3QXGJUOG5THRX
62	Nooyi	ABFS5TDY6LZNA
63	NOTTODAY	A3S88F4ORA904G
64	Oaken.OC9	A2LBTJ4DJQ85HA
65	orgen	A29ZTMV1PGB313
66	Original strength	ACVVZMVDJD971
67	Pacific-Home	A101LMTM9SJTJR
68	Pamlulu	A3ECFQ4JCPB2ZK
69	PNPCORP	A3VZETOCQRLQRW
70	Prep Sellers	AQI96X0P68180
71	Qouya Direct	A5B3L0GDJGJ2M
72	QP Import Shop	A16CZEJ6UZKOJ9
73	RJSEMIFUN	A20IW23DGCN59H

74	ROYI	AION4MBMNOSQ1
75	SDEER	APJ40UTQTO3ZP
76	Sherry Mei	A3L25SVOB5O0ND
77	Singska	A3PHC31CZ9QG6E
78	SmartPet (Formerly Known As QPQEQTQ)	A39LUGBQZM45RQ
79	Smoothedo	A2QNX1667XQR64
80	Soar Company Limited	ABHW0YRNLZDAI
81	SOLCLAIR	A3CE0WUVA70I2S
82	Song Yuan	A2M4EHE8HBPOAM
83	SPLOVEUNIAA	A1A17HBMAV0S3Y
84	Squishyland	A111QTMTAAAFU8
85	Star Pets Co.	A2YYBLWBQ55N77
86	Start US	A171IIL06RBPJ5
87	Super Store - Symington	A8CJCC0K1MERY
88	TAKEBEST-US	ASB1IXO9O6LAO

89	Tall shop	A2Z96SY8672GBG
90	Time4Deal	A2NRXN29VIRA1V
91	TINY Fun (Formerly Known As SFYjunhao)	AARSYJHPVT5UK
92	Today's Deals Store	A29X7F4112D6LH
93	TOLOCO MAX	A3LM29QNJTJ4YW
94	Trans Global	A31JT4RCS4EPR5
95	usams original	A3K2RIQKJ8SW2W
96	WAK-US	AYYV4X5XQ6A7O
97	WANKADA	A3QI1JHBDN2JSU
98	WeipuTek	A20F2K66M5H7R7
99	WellnessPic	ALI94TR7IPL0O
100	Winsb	A33C2BFU0OSBLW
101	wonderful320	AATDU7ZJEZK05
102	woowi0760	A35H1SJPCAGBPM
103	Xi Ting	A28LZPPVYER8VP

104	YCL-US	AEBPR4AHQIKUQ
105	YeePee	A2W3SBIT2R3OYC
106	YStech	A3SY16CS62BSU8
107	ZCISSY	A2QNNNZN2K33W6
108	ZCXINW	AJTCY0WAPBPZV
109	ZergStore	AFLWH54SY0QFI
110	ZISITA	A1I1KBQGAK3KBQ
111	ABEDOE DropShipping Store	4430072
112	ABEDOE Energetic Store	4412156
113	ABEDOE Franchised Store	3091109
114	Animal Zone Store	5570006
115	Arctangent Store	5068441
116	Betterpet Store	5191019
117	Bolux Official Store	4242008
118	chinely Store	5068164
119	CHONGLEGU Official Store	5369301

120	Cindy Homeware Store	4506014
121	Comfortable Pets House Store	1934942
122	Daily Gadgets Store	5049011
123	Daily Life House Store	5419227
124	Do Drop shipping Store	3514108
125	Dogbaby Official Store	1817157
126	Dreaming Life Store	2335118
127	DSRAY Store	4385019
128	DT Store Store	5073076
129	Easydream Store	5050290
130	ETSREWO Store	5209005
131	Facemask factory Store	5737156
132	FARM ASSISTANT Store	1702147
133	FIYDNDS Store	4979086
134	Green HoneyPet Store	5371089
135	H&F Store	2906124

136	Halashop Store	5007150
137	HANTAJANSS Store	4428002
138	HappyPet Store	3866042
139	herehere Store	5441303
140	HEYPET Store	2389086
141	HomeYard Store	424242
142	HTOP Homeliving Store	5564084
143	Janree Life Store	5545007
144	Jayhome Store	4058012
145	JOYLIVE Store	5789518
146	Joylove Store	5429126
147	Junejour Direct Store	5401045
148	KathleenHouse0086 Store	5370219
149	KEMISIDI Kemisidi Store	4526038
150	KkM 5072153 Store	5072153
151	League of Pets Store	5006319

152	Leisure and Holidays Store	5517077
153	LemonBest Franchised Store	1767312
154	LemonBest Intelligent Store	4627028
155	Lhuang Online Store	5419212
156	LiXing retail Store	5507028
157	LovePets Store	3474026
158	LYPet Store	4038010
159	MGKPET Global Store	5049344
160	Mt homeware Store	5499083
161	Overseas Dropshipping Factory Store	5419171
162	Pawaca House Store	2801150
163	Paws Up Store	3376023
164	PetCloud Store	5378198
165	Pets Homes Store	5042204
166	QLUQ Garden Store	4881025
167	SAB loves life Store	5277021

168	Shergut Store	4503097
169	Shop beautiful life Store	3100045
170	shop09201996 Store	5017168
171	Shop4399105 Store	4399105
172	Shop5243276 Store	5243276
173	Shop5251291 Store	5251291
174	Shop5251295 Store	5251295
175	Shop5316019 Store	5316019
176	Shop5367212 Store	5367212
177	Shop5568062 Store	5568062
178	Shop5680040 Store	5680040
179	Shop5700129 Store	5700129
180	Shop5794112 Store	5794112
181	S-I-M-P-L-E Store	5069022
182	Smartpet Store	4706019
183	STRIKATE Store	4767032

184	Tianxuan03 Store	4410179
185	TieHo Warm House Store	5249063
186	TOPFENG Harvest Store	4429180
187	Ultrasound Pet David Store	4826012
188	Ultrasound Pet Mimi Store	5438156
189	Ultrasound Pet Official Store	4637027
190	VOFORD Official Store	4002007
191	warming Store	5051239
192	WEIXINBUY Franchise Store	3115085
193	Wonder For Pets Store	5110009
194	XinLing Store	5623178
195	XinluHome Store	4644096
196	XinYou Store	4391017
197	YOCOMYLY 511511 Store	511511
198	YU2019 Store	5048186
199	Zhangyi HomeGarden Decoration	1271096

	Store	
200	Zloog Official Store	5045006
201	aJIESHOW	5d57db89560eca4252eebc98
202	Alicebaby678	5993eac7eea5c56ee78660d0
203	Annie baby store	591057257e5f0b2c1732becb
204	Bestope	5a15526c9fbc5165f55c3590
205	biigeoled580	5d5f9b753d24b75081c4fe80
206	caiju temai lucky	5af6b7715ccdca7afc2e26d0
207	Changushop	58170c628d2bf61987815cc0
208	Cheetahqiong	5ab10cfda6bf7a56f1df6394
209	chenlipingstory	5b3478dab40ac115187e8adc
210	chunfuwanjudian	5b3f032f1c895306f19469be
211	CieloSport	5dca20c4739c24024063c575
212	clix4129	5dc03b85df5137841cb0b673
213	Corey Rappe	5e73964a5021d6c9903ff08d
214	cy916	5abcd55c22fad77e75eb83fd

215	fangmingso	5e16dab28ea5a7048d448532
216	fashion tools	58d65c417586f72c8f9ec0f8
217	fenfenmen	5b3b00348584ad1524d5a250
218	Fengnalia	5ca9ac8ca6ab651cee25c8de
219	FU GUI Convenience Store	5d5d55001d862975e9bfd798
220	fuzhouyoukenmaoyiyouxiangongsi	570b82003a698c33a07a16ff
221	gaomeijiao2156	5d47ba2d4f7ba752bfd67bf7
222	gegecompany	581da4ac34afa75459f662b5
223	Giftenza	5e778af629e7865cfc55bd63
224	Global MTshop	5cbf1ee84cd44a132973af95
225	GLORIOUSHOW	5ad04c5b421595798d8f43e2
226	gongjiangyang	5a1678f77276537ea2ea0651
227	H877XOQPU	5e7ba756865f1a94b08c4b7e
228	hannamace	5e43ba34e763db5d7a4921d1
229	HH_mango	5d3d91b3ab0c792ec0a59d1c
230	hongxihualaptop	591c04c5dce6ce2d9db269d0

231	hudaleng	5b5144971e70532481b05343
232	hzsdyouth23	58d617d962982052aba8da51
233	ImixExpressive Faith	5dff6d328a92b34c7320789d
234	j83491860	59f71424518c1c0c7512bd82
235	josed02	5dc21a5480c41b0395ddff52
236	La Boleada	5da5e26ac095e14580b49b38
237	Love for Life&Self	5dff02ef0cfa143d49e76cab
238	Make Shopping Funny Again	5bec2cc99639b4595b027ba0
239	milk bread	58c10f544aae6052172673d9
240	Ming Fashion Store	548ef2cbb9cb9261bf879445
241	mingpingmai	5b67c4a303523d3d4887721b
242	mumu913	5e54a35d35caa93e35006d17
243	MyDeal365	5ac3036ba71fbf304137ae49
244	Mymin2543	5def477670f95b0392d61767
245	Mzjh33	58bd59029657445312713e83
246	nantengda	5e84203cab205e7eae8dcb37

247	nbosoppxksm	5aefbfe01c25004e5cfbf313
248	Newfirepinler	58b3dcfdcb842150e9cc8b7d
249	Ninghai sunray	58a166727477cb510673faaf
250	nishgnekahgd	5a9e9c7267d25c2510337f5f
251	nxhipnner	5b14a51b7e43f21f285ebbf6
252	oufuheng	580cb7ce251ffe199bc07159
253	OverlackCat	5ab886b61c256d1f094e3f04
254	Pampers	5def4e0370f95b047ed61852
255	Panatienda	5de5dcc602c87406d35c9b91
256	Pandita	5dab2f1569ce7503c0f82e16
257	pinaozhao70	5b4febef0fa3695898e47e0e
258	qtwkgnu	5d4fedc47ad24274cbf71fd4
259	Save Your Dollars	5b4cc056d5dbc250fee33b3e
260	sdagjk	5d4ec4911527546dc2ad52ec
261	Sea eating	5d5a889c2736784edc1780fe
262	seekNfind	5e91f67c1a25abd3afb767f9

263	SEHbesthair	56a9c2423a698c52507694f6
264	sellingfun	53a94b04ff4d6d61827b593b
265	Shenzhen Shi Sande Keji Youxian Gongsi	5b4c18a5aa70863379694d06
266	shenzhenmingshunxin	54215d7cf420dd08ee38cff5
267	shizihuibao	5a0587728cf0ed27084f76d7
268	shopauction	599e82ae2351346206c3cd71
269	skkyy	5e61bcac2ff71a004e9c6d07
270	Smart - Kids Juicer	595b972737635d60b412e62e
271	Smartpp	58e61422d1ac210fb0b52919
272	Solarfly	584e57452f5e535aaf9b61d1
273	stallings	5e43cbd92906c929006dda7f
274	suneuisn2	5e0ae54a4f77a60234ce7c02
275	TOAEON	5d48dd3360c79c63c169fb1f
276	tkxtxf	59a7cc93bf255305c95d0a38
277	uvshopping	58ee0d4fca1ebd5e5725f1bd

278	Vending shops	57640e526dd5a55e28205152
279	W5 Factory	5d5deaac560eca35ca0f187a
280	wenvhgrte10	5e4ce21401ba9d174f318fc9
281	WWD Fashion Store	5d85c90ea9356a4e79a74ce4
282	XD Fashion Store	5d786b2a51da4f64ca27dcc6
283	xiaoyesmile	58f09a598a60c363bf281c23
284	YDH789	5af51bb98699ce7c14d20389
285	yiblakeji	5e43ab4f2906c94e3d6d5788
286	yklesdest88	5d61f62040defd5a1f888092
287	ZeWoo-Shop	547884818edcfa5656ca94d5
288	ZRKKGM	5d57aeb640defd63baaca7ea
289	zuccyouth0139	59f5421be6503337d8899a16
290	ZX007	5e92c98c1a25ab2180bad479
291	ZZ YIZE	5d5cc17d40defd36e7a725a3

LISTING OF EXHIBITS

- Exhibit 1.....U.S. Trademark Reg. No. 5,815,298 for BRISTLY
- Exhibit 2.....U.S. Trademark Reg. No. 5,844,832 for BRISTLY
- Exhibit 3.....U.S. Copyright Reg. No. VA 2-122-455 for “Photos of In Use
Pet/Dog Toy for Oral Hygiene”
- Exhibit 4.....European Registered Community Design No. 005818606-0001
- Exhibit 5.....U.S. Patent No. 10,477,838
- Exhibit 6.....Comparison of Type 1 Infringing Product to claim 1 of U.S. Patent
No. 10,477,838
- Exhibit 7.....Comparison of Type 2 Infringing Product to claim 1 of U.S. Patent
No. 10,477,838
- Exhibit 8.....Comparison of Type 3 Infringing Product to claim 1 of U.S. Patent
No. 10,477,838
- Exhibit 9.....Comparison of Type 4 Infringing Product to claim 1 of U.S. Patent
No. 10,477,838
- Exhibit 10.....Comparison of Type 5 Infringing Product to claim 1 of U.S. Patent
No. 10,477,838
- Exhibit 11.....Comparison of Type 6 Infringing Product to claim 1 of U.S. Patent
No. 10,477,838

EXHIBIT 1

United States of America

United States Patent and Trademark Office

BRISTLY

Reg. No. 5,815,298

Registered Jul. 23, 2019

Int. Cl.: 3

Trademark

Principal Register

Dertsakyan, Peter (UNITED STATES INDIVIDUAL)
7700 Babcock Ave
North Hollywood, CALIFORNIA 91605

CLASS 3: Non-medicated dental preparations for pets, namely, toothpaste and preparations for removing plaque; Home dental care products for dogs and cats, namely, toothpaste; Dental care and oral hygiene products for pets, namely, tooth cleaning preparations; Non-edible dental chews for pets; Non-medicated oral dental chews for dogs

FIRST USE 6-00-2018; IN COMMERCE 6-00-2018

THE MARK CONSISTS OF STANDARD CHARACTERS WITHOUT CLAIM TO ANY PARTICULAR FONT STYLE, SIZE OR COLOR

SER. NO. 88-177,120, FILED 10-31-2018



Andrei Iancu

Director of the United States
Patent and Trademark Office

EXHIBIT 2

United States of America

United States Patent and Trademark Office

BRISTLY

Reg. No. 5,844,832

Registered Aug. 27, 2019

Int. Cl.: 21

Trademark

Principal Register

Dertsakyan, Peter (UNITED STATES INDIVIDUAL)
7700 Babcock Ave
North Hollywood, CALIFORNIA 91605

CLASS 21: Toothbrushes for animals; Toothbrushes for pets; Home dental care products for dogs and cats, namely, toothbrush

FIRST USE 2-1-2017; IN COMMERCE 2-1-2017

THE MARK CONSISTS OF STANDARD CHARACTERS WITHOUT CLAIM TO ANY PARTICULAR FONT STYLE, SIZE OR COLOR

SER. NO. 88-310,557, FILED 02-21-2019



Andrei Iancu

Director of the United States
Patent and Trademark Office

EXHIBIT 3

Certificate of Registration



This Certificate issued under the seal of the Copyright Office in accordance with title 17, *United States Code*, attests that registration has been made for the work identified below. The information on this certificate has been made a part of the Copyright Office records.

Kay A. Leigh

Acting United States Register of Copyrights and Director

Registration Number

VA 2-122-455

Effective Date of Registration:

September 27, 2018

Title

Title of Work: Photos of In Use Pet/Dog Toy For Oral Hygiene

Completion/Publication

Year of Completion: 2018
Date of 1st Publication: June 20, 2018
Nation of 1st Publication: United States

Author

◦ Author: Petros Dertsakyan
Author Created: photograph, 2-D artwork
Citizen of: United States
Domiciled in: United States
Year Born: 1987

Copyright Claimant

Copyright Claimant: Petros Dertsakyan
7700 Babcock Ave., North Hollywood, CA, 91605, United States
Transfer statement: author is claimant

Limitation of copyright claim

Material excluded from this claim: sculpture
New material included in claim: photograph, 2-D artwork

Rights and Permissions

Organization Name: David R. Preston, Ph.D., J.D., APC
Name: David Preston
Email: preston@drpna.com
Telephone: (858)724-0375
Alt. Telephone: (858)735-7132

Address: 10765 Wallingford Road
San Diego, CA 92126 United States

Certification

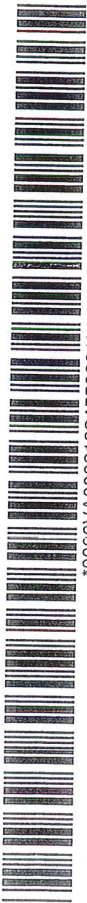
Name: David R. Preston
Date: September 27, 2018
Applicant's Tracking Number: DOGD-106.C.3

Correspondence: Yes
Copyright Office notes: Basis for Registration: Unit of publication



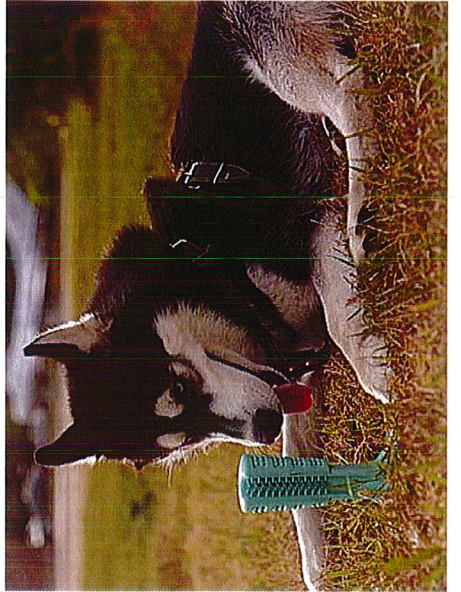
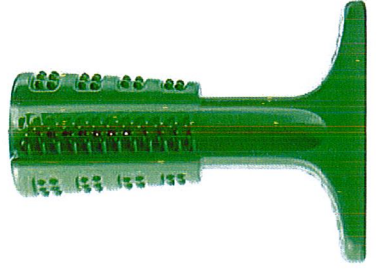
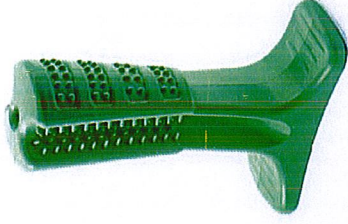
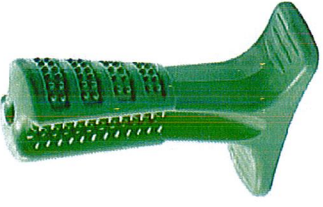
Registration #: VA0002122455
Service Request #: 1-6990498131

David R. Preston, Ph.D., J.D., APC
David Preston
10765 Wallingford Road
San Diego, CA 92126 United States

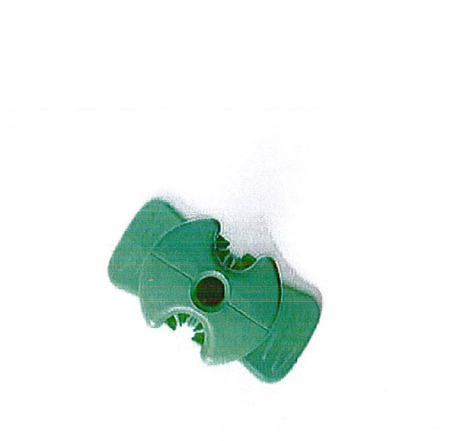
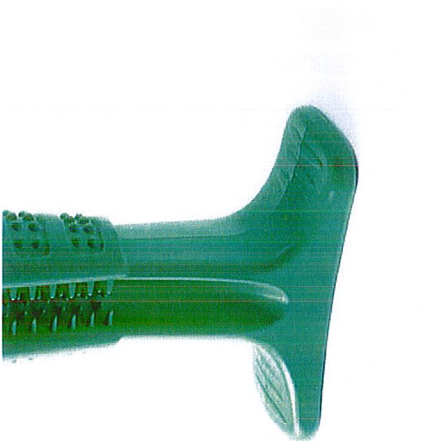
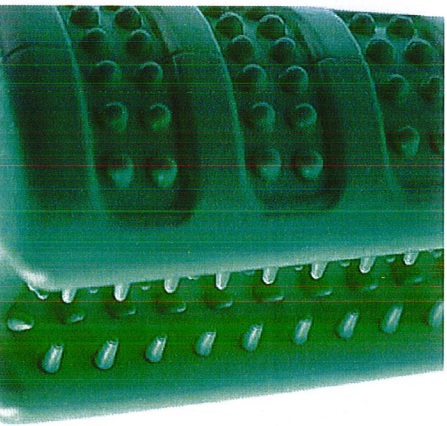
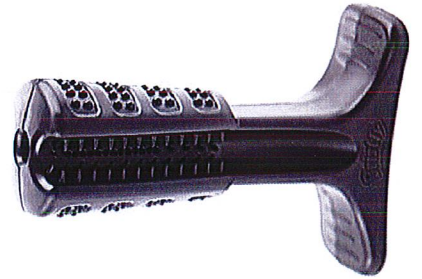
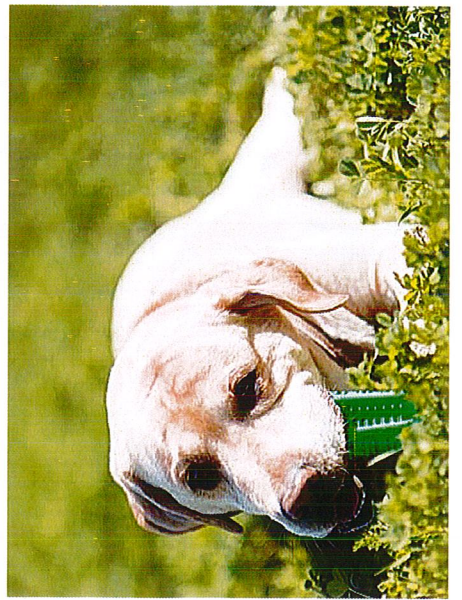
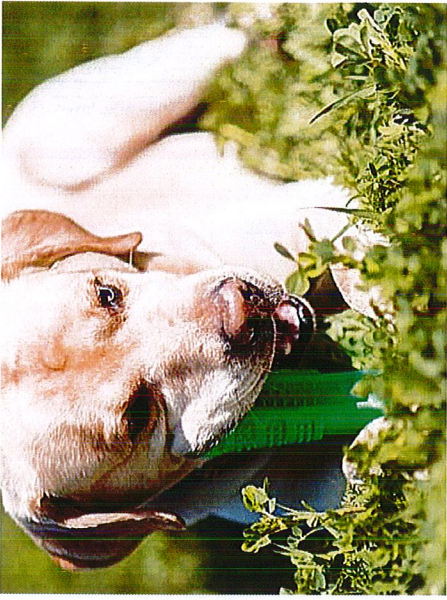


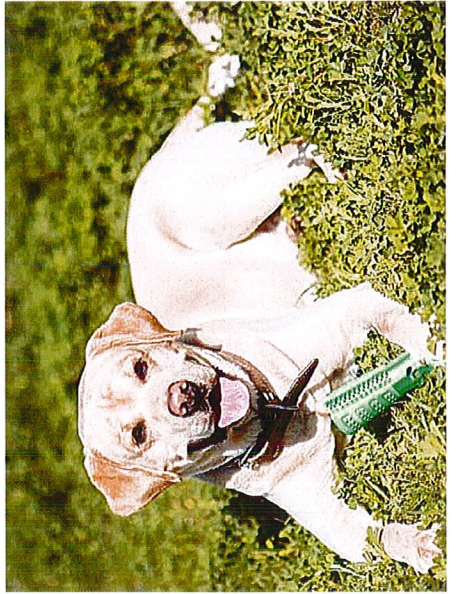
0000VA0002122450201

Deposit Materials

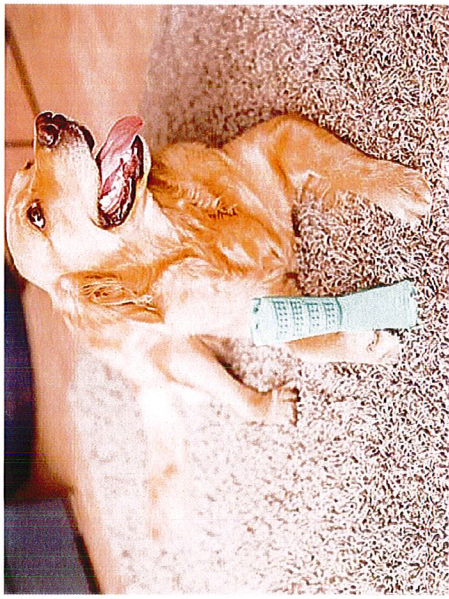
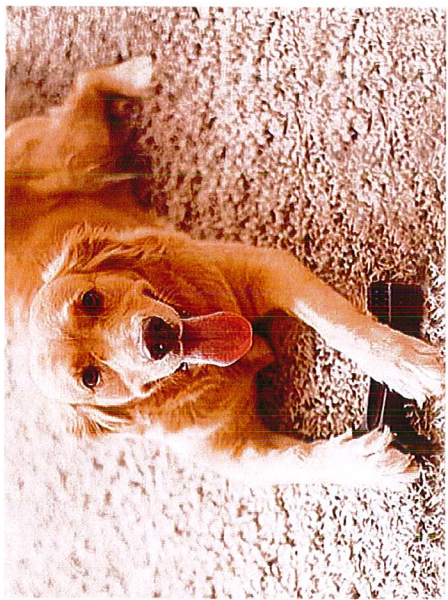
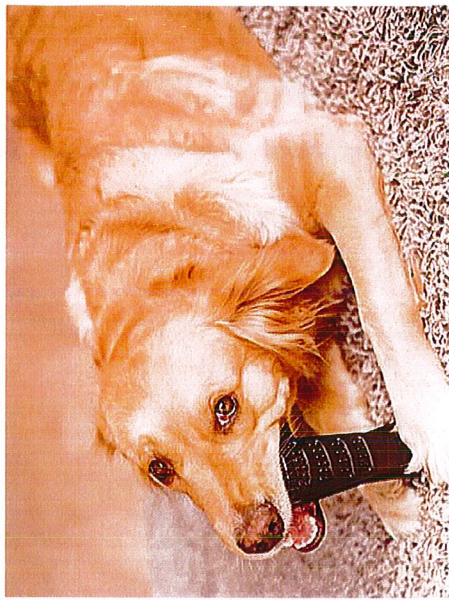


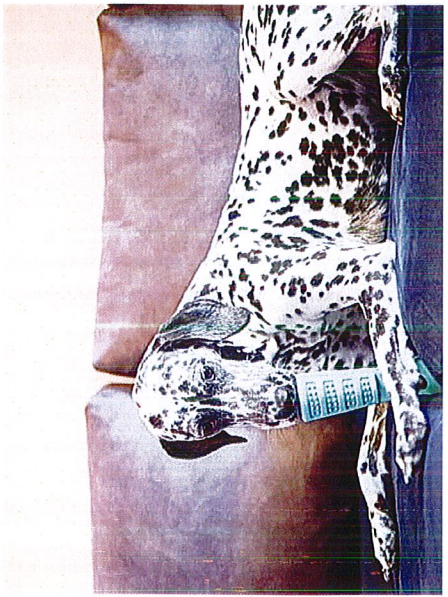
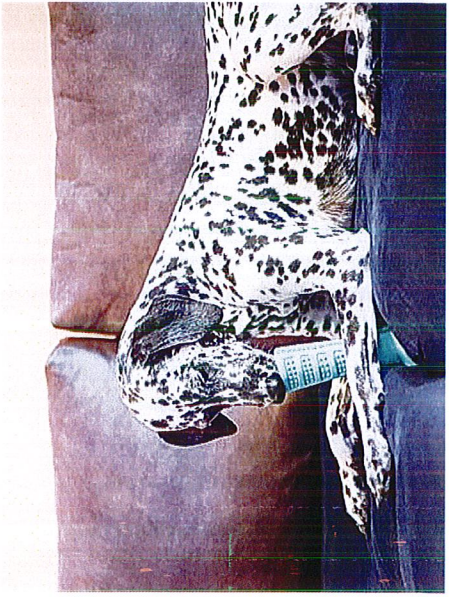
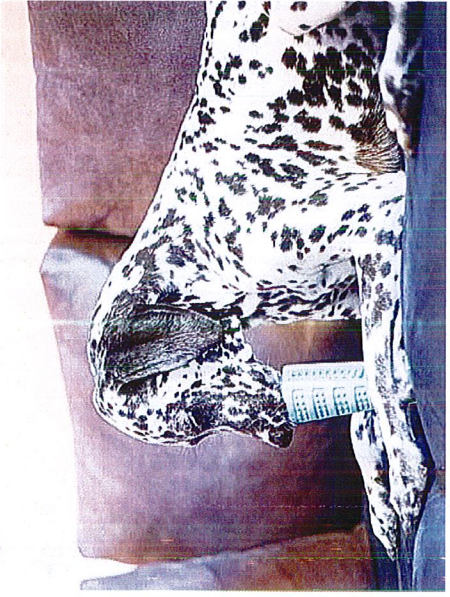
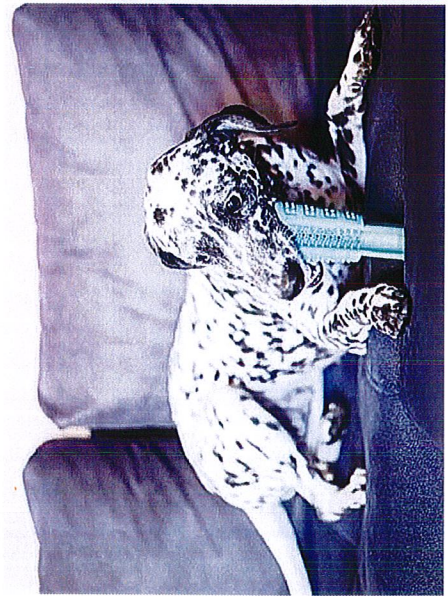
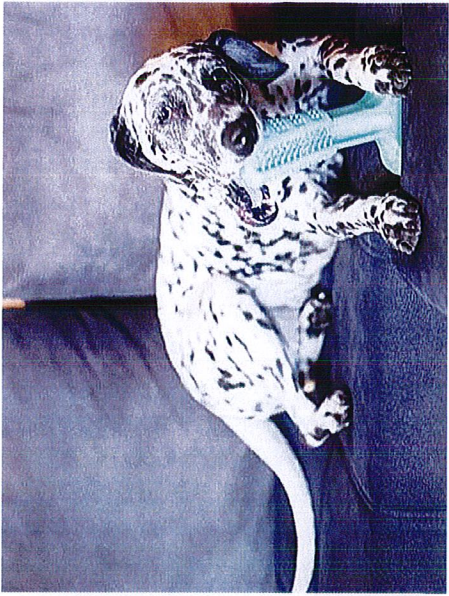
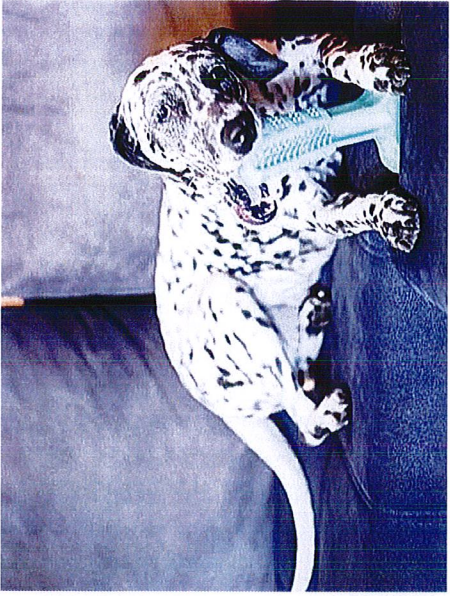
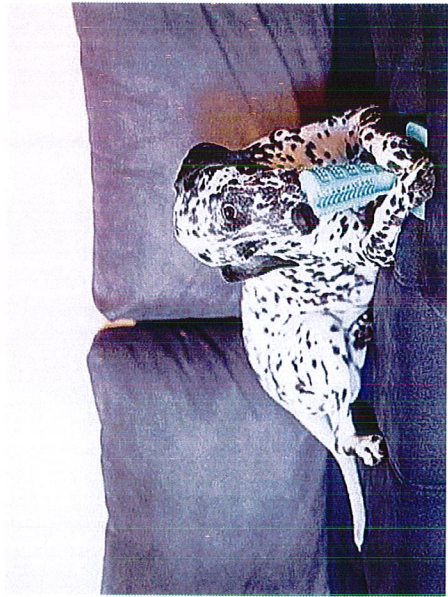
www.Brits

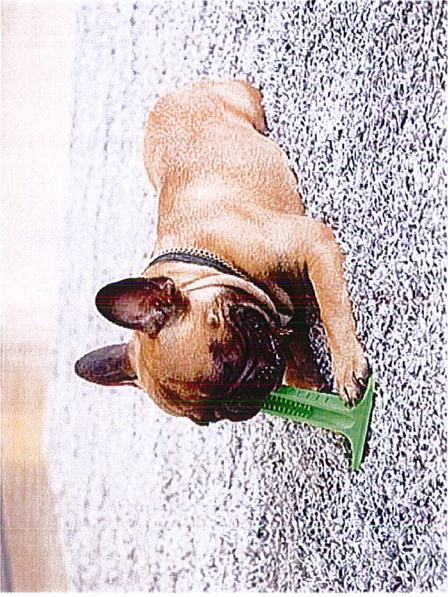












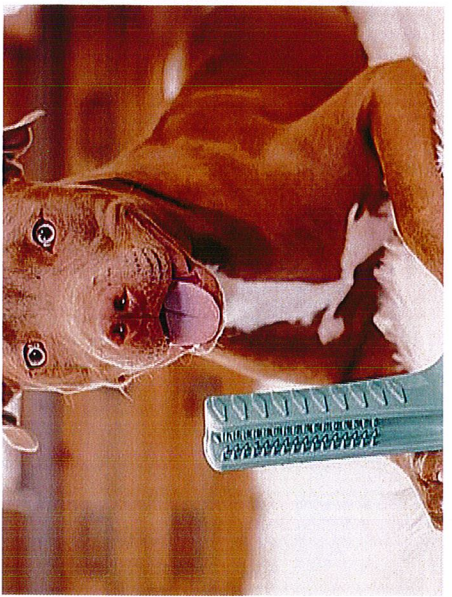
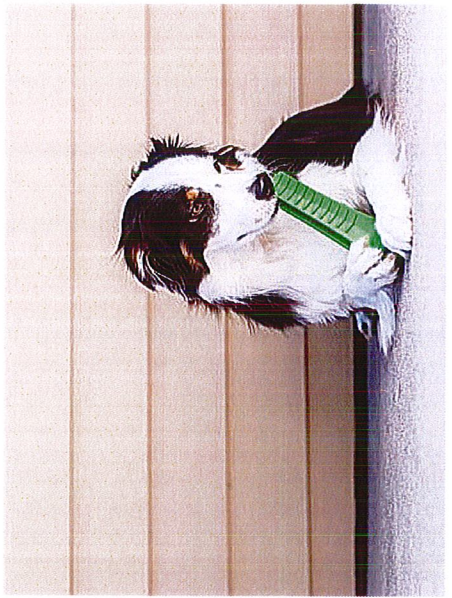
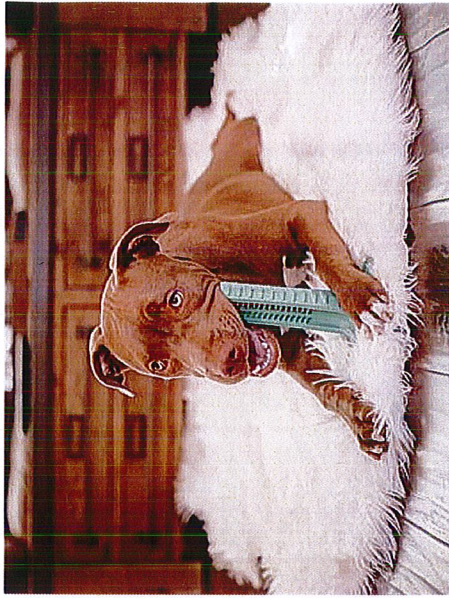




EXHIBIT 4

Registered / Eingetragen 07/11/2018

No 005818606-0001



EUROPEAN UNION INTELLECTUAL
PROPERTY OFFICE
CERTIFICATE OF REGISTRATION

This Certificate of Registration is hereby issued for the
Registered Community Design identified below. The
corresponding entries have been recorded in the
Register of Community Designs.

AMT DER EUROPÄISCHEN UNION FÜR
GEISTIGES EIGENTUM
EINTRAGUNGSRUKUNDE

Diese Eintragungsurkunde wird für das unten genannte
eingetragene Gemeinschaftsgeschmacksmuster
ausgestellt. Die entsprechenden Einträge sind in das
Register für Gemeinschaftsgeschmacksmuster
aufgenommen worden.

The Executive Director / Der
Exekutivdirektor

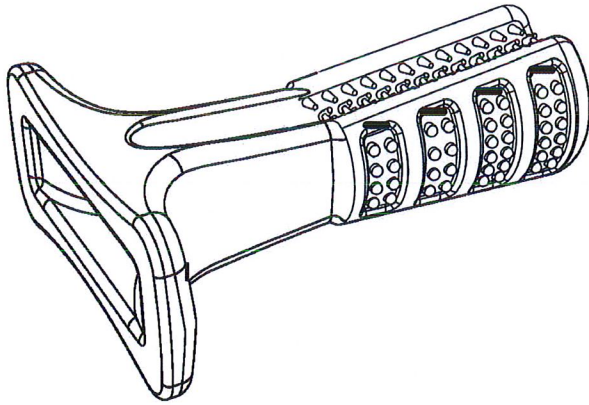
Christian Archambeau

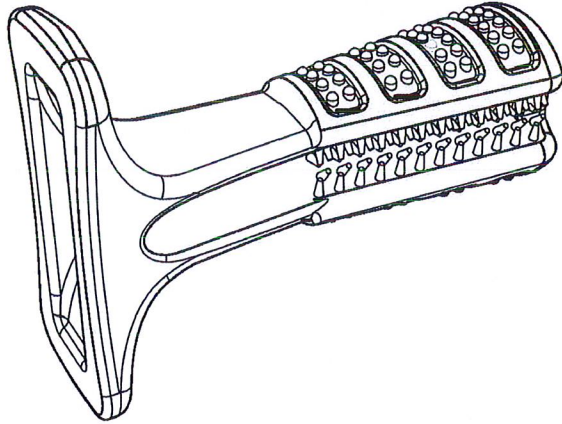


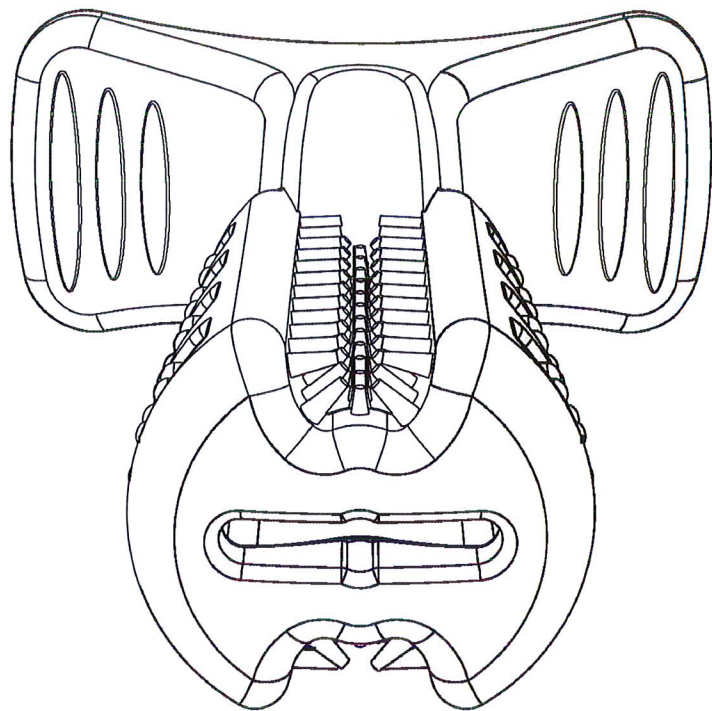
www.euiipo.europa.eu

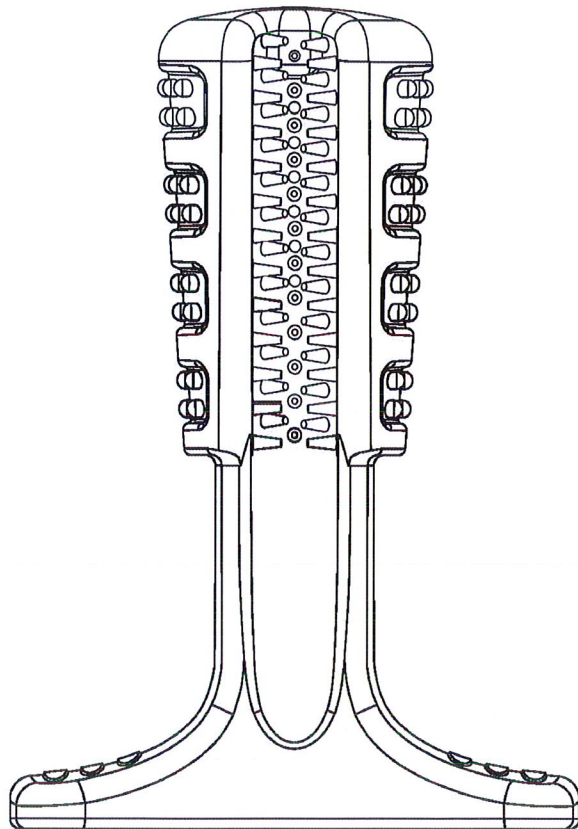


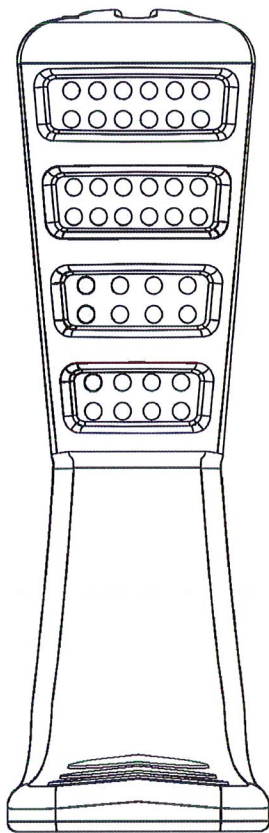
21 005818606-0001
25 EN - DE
22 07/11/2018
15 07/11/2018
45 15/01/2019
11 005818606-0001
73 Peter Dertsakyan
7700 Babcock Avenue
North Hollywood California 91605
ESTADOS UNIDOS (DE AMÉRICA)
74 SCHAUMBURG UND PARTNER PATENTANWÄLTE MBB
Mauerkircherstr. 31
D-81679 München
ALEMANIA
51 30 - 99
54 **BG** - Играчки за животни
ES - Juguetes para animales
CS - Hračky pro zvířata
DA - Legetøj til dyr
DE - Spielzeug für Tiere
ET - Loomamänguasjad
EL - Παιχνίδια για ζώα
EN - Toys for animals
FR - Jouets pour animaux
IT - Giocattoli per animali
LV - Dzīvnieku rotaļlietas
LT - Gvūnų žaislai
HR - Igračke za životinje
HU - Játékok állatoknak
MT - Ġugarelli għall-animali
NL - Speelgoed voor dieren
PL - Zabawki dla zwierząt
PT - Brinquedos para animais
RO - Jucării pentru animale
SK - Hračky pre zvieratá
SL - Igrače za živali
FI - Eläinten lelut
SV - Djurleksaker
30 US - 18/09/2018 - 29/663,715
57
55

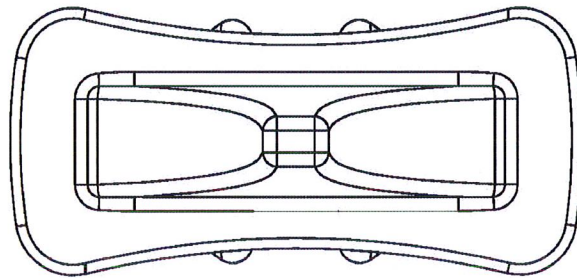












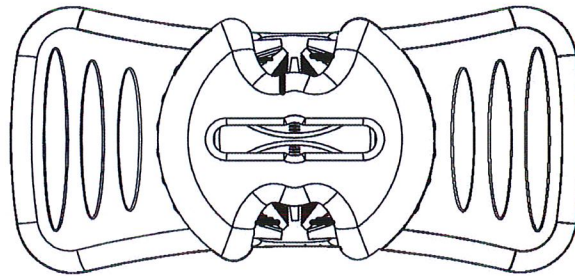


Exhibit 5



US010477838B2

(12) **United States Patent**
Dertsakyan

(10) **Patent No.:** **US 10,477,838 B2**
(45) **Date of Patent:** **Nov. 19, 2019**

(54) **PET CHEW TOY FOR DENTAL
SELF-CLEANING BY DOMESTIC PETS**

(71) Applicant: **Peter Dertsakyan**, North Hollywood,
CA (US)

(72) Inventor: **Peter Dertsakyan**, North Hollywood,
CA (US)

(*) Notice: Subject to any disclaimer, the term of this
patent is extended or adjusted under 35
U.S.C. 154(b) by 0 days.

(21) Appl. No.: **15/472,206**

(22) Filed: **Mar. 28, 2017**

(65) **Prior Publication Data**

US 2018/0295811 A1 Oct. 18, 2018

Related U.S. Application Data

(60) Provisional application No. 62/314,353, filed on Mar.
28, 2016.

(51) **Int. Cl.**
A01K 15/02 (2006.01)
A46B 9/02 (2006.01)
A46B 1/00 (2006.01)

(52) **U.S. Cl.**
CPC **A01K 15/026** (2013.01); **A46B 1/00**
(2013.01); **A46B 9/026** (2013.01); **A46B**
2200/1086 (2013.01)

(58) **Field of Classification Search**
USPC 119/702, 709–711; D30/160; 426/805,
426/144, 143, 104; 433/1; 424/442, 49
See application file for complete search history.

(56) **References Cited**

U.S. PATENT DOCUMENTS

1,408,520	A *	3/1922	Larsen	401/183
3,007,441	A *	11/1961	Eyer	A01K 13/002
					15/167.1
3,853,412	A *	12/1974	Griffin	A46B 11/0041
					15/104.061
5,072,481	A *	12/1991	Frank Weyer	A46B 5/0054
					15/167.2
D325,821	S *	5/1992	Schwartz	D4/106
5,360,026	A *	11/1994	Klinkhammer	A46B 5/002
					132/308
5,407,287	A *	4/1995	Braun	A46B 11/0017
					401/176
5,497,526	A *	3/1996	Klinkhammer	A46B 5/0012
					132/309
5,711,759	A *	1/1998	Smith	A61J 17/006
					601/139

(Continued)

OTHER PUBLICATIONS

Materials relating to Busy Buddy Bristle Bone, from www.chewy.com, obtained Sep. 25, 2018.

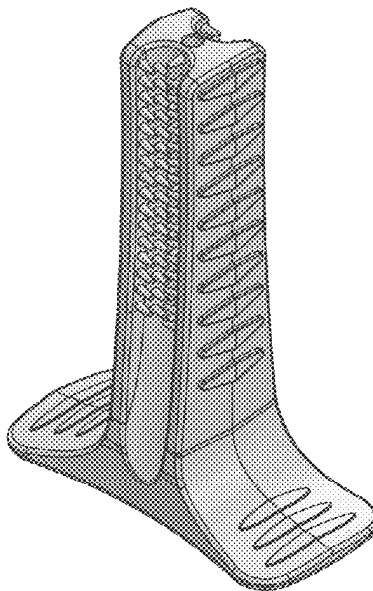
(Continued)

Primary Examiner — Andrea M Valenti
(74) *Attorney, Agent, or Firm* — David R. Preston

(57) **ABSTRACT**

A pet chew toy allowing for the self-cleaning of teeth by domestic pets. The pet toy includes one or more cavities into which a pet's teeth may engage, and the inner and outer surfaces of the cavities may have scrubbing elements designed to enhance removal of plaque and other unhygienic products from a pet's teeth and gums. The chew toy may further include projections to enhance stabilization of the chew toy by the pet, and a reservoir and dispensing system for pet toothpaste or similar additive.

17 Claims, 6 Drawing Sheets



(56)

References Cited

U.S. PATENT DOCUMENTS

5,842,249 A * 12/1998 Sato A46B 5/0008
15/167.2
5,944,516 A * 8/1999 Deshaies A61D 5/00
15/167.1
D417,319 S * 11/1999 Weiss, Jr. D30/119
6,116,191 A 9/2000 Suchowski
6,148,771 A * 11/2000 Costello A01K 15/026
119/709
D453,242 S * 1/2002 Kaplan A01K 15/026
D30/160
6,405,681 B1 * 6/2002 Ward A01K 15/026
119/707
6,739,287 B1 5/2004 Sarantis
D501,961 S 2/2005 Jager
D564,714 S * 3/2008 Axelrod D30/160
7,490,579 B2 2/2009 Axelrod
D635,309 S * 3/2011 Axelrod D30/160
8,166,600 B2 * 5/2012 Lee A46B 5/0062
15/167.1
8,807,088 B2 8/2014 Axelrod
8,935,992 B2 * 1/2015 Axelrod A01K 15/025
119/709
D771,326 S * 11/2016 Lai D30/160
9,744,014 B2 * 8/2017 Smith A61C 19/04
9,770,010 B2 * 9/2017 Wechsler A01K 15/026
2002/0083539 A1 * 7/2002 Bella A46B 5/0016
15/106
2004/0137118 A1 7/2004 Axelrod
2004/0216693 A1 11/2004 Handelsman
2005/0015908 A1 * 1/2005 Hanlon A46B 5/02
15/167.2
2006/0150919 A1 * 7/2006 Thomason A01K 15/026
119/710
2007/0015100 A1 * 1/2007 Morris A61D 5/00
433/1

2007/0101946 A1 * 5/2007 Penny A01K 13/00
119/709
2009/0208898 A1 * 8/2009 Kaplan A46B 9/045
433/80
2009/0276972 A1 * 11/2009 Dugan A46B 7/00
15/167.2
2011/0011351 A1 * 1/2011 Simoni A01K 15/026
119/709
2013/0266905 A1 * 10/2013 Smith A61C 19/04
433/1
2013/0305999 A1 * 11/2013 Axelrod A01K 15/026
119/710
2014/0060442 A1 * 3/2014 Ressemann A01K 13/00
119/61.5
2014/0123421 A1 * 5/2014 Minano Fernandez
A46B 9/045
15/110
2014/0224184 A1 * 8/2014 Dewey A01K 15/026
119/709
2018/0243063 A1 * 8/2018 Coopersmith A01K 15/026

OTHER PUBLICATIONS

Materials relating to Busy Buddy, from www.petsafe.net, obtained Sep. 25, 2018.
Materials relating to Busy Buddy Bristle Bone, from <https://ps.factoryoutletstore.com>, obtained Sep. 25, 2018.
Materials relating to Busy Buddy Bristle Bone, from <https://store/petsafe.net>, obtained Sep. 25, 2018.
Materials relating to Nylabone DuraChew Double Action Round Ball Bacon Flavor Dog Toy, from www.chewy.com, obtained Sep. 25, 2018.
Materials relating to Nylabone DuraChew Double Action Dental Chew Bacon Flavor Dog Toy, from www.chewy.com, obtained Sep. 25, 2018.

* cited by examiner

Figure 1

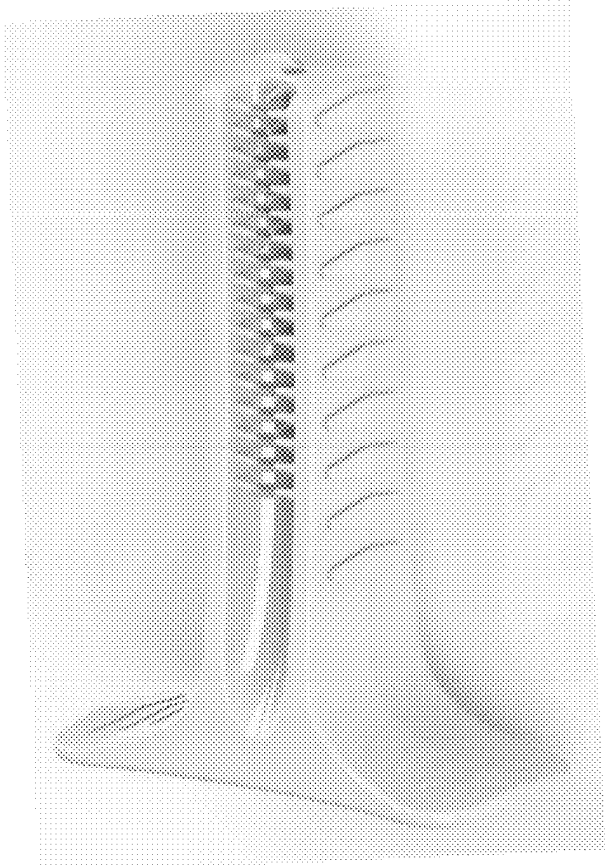


Figure 2

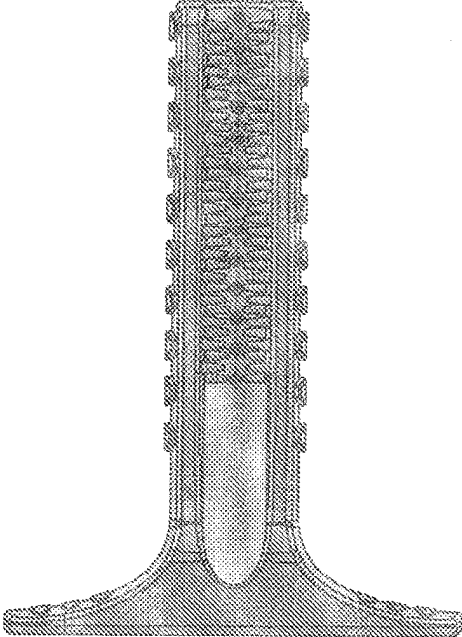


Figure 3

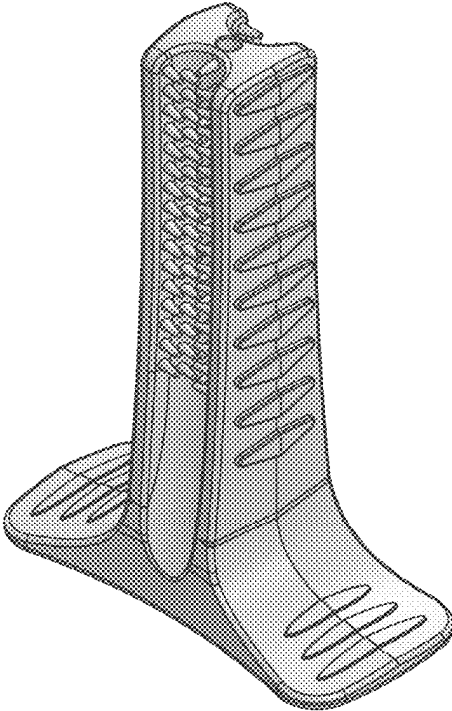


Figure 4

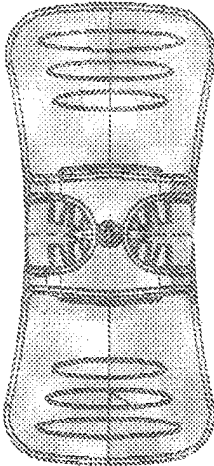
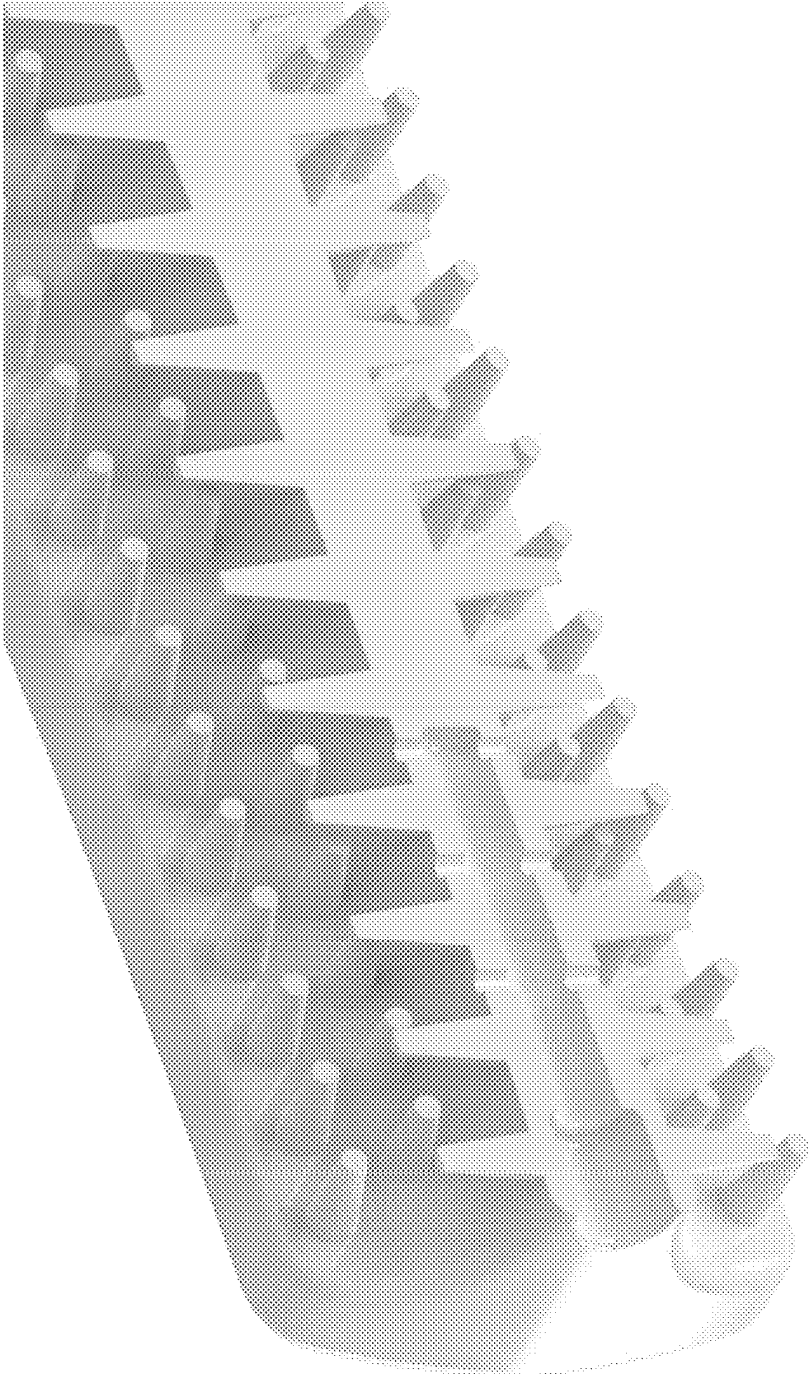


Figure 5



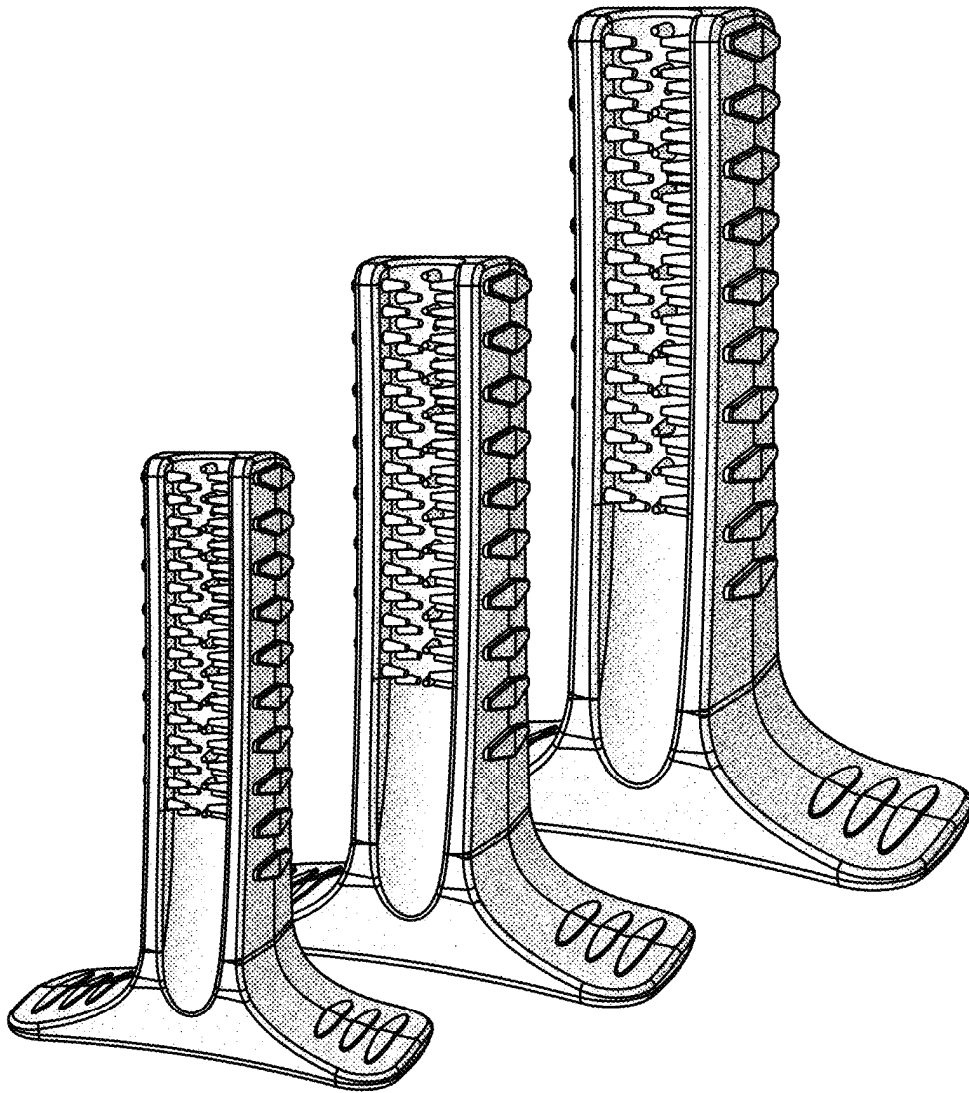


FIG. 6

1

**PET CHEW TOY FOR DENTAL
SELF-CLEANING BY DOMESTIC PETS**

CROSS-REFERENCE TO RELATED
APPLICATIONS

The present application claims priority to provisional application 62/314,353, filed Mar. 28, 2016, entitled "Toy for a Domestic Pet to Brush Its Own Teeth" which is incorporated by reference in its entirety herein.

STATEMENT REGARDING FEDERALLY
SPONSORED RESEARCH

Not applicable.

JOINT RESEARCH AGREEMENT STATEMENT

Not applicable.

FIELD OF THE INVENTION

The present invention relates to a pet chew toy and dental hygiene system, and particularly to pet chew toy allowing for the dental self-cleaning by domestic pets.

BACKGROUND

Maintaining the dental hygiene of domestic pets is a well-known issue. Like humans, domestic pets such as dogs and cats develop bacterial infections, known generally as plaque, on the surface and in the spaces between the teeth of said pets. In addition to the malodorous breath and appearance of domestic pets suffering from an excess of plaque, it can also precipitate the gum disease gingivitis, damage to the pet's teeth, and other material detriment to the oral health of the pet. If left routinely uncleaned, it can harden and become almost impossible to remove without professional assistance.

Traditional methods of cleaning the teeth of pets has involved labor-intensive manual cleaning by the pet owner, a process which is both time-consuming and often results in unnecessary antagonism between the domestic pet and its owner.

Wild relatives of domestic pets, such as wild dogs and wolves, use the frictional effects of gnawing on bones and other hard objects to clean their teeth of plaque and residual pieces of food. The use of domestic pet chew toys as a method of mimicking these natural dental hygiene methods for domestic pets is known in the art. As a consequence, many domestic animal chews or chew toys have been produced of rawhide or other hard surface and configured in such a way as to mimic the shape and feel of natural bone. Other products have introduced additional artificial features to improve upon the natural cleaning action of a domestic pet's chewing action on bone, such as the use of additional projections on a surface of the chew toy.

Information relevant to attempts to address these problems can be found in US Patent Application No. 2004/0216693 to Handelsman; U.S. Pat. No. 6,116,119 to Suchowski; U.S. Pat. No. 6,739,287 to Sarantis; U.S. Pat. D501,961 to Jager; US Patent Application no. 2004/0137118 to Axelrod; and U.S. Pat. Nos. 8,807,088 and 7,490,579 to Axelrod. However, each one of these references suffers from one or more disadvantages. One consistent failing of existing products relates to a domestic pet's propensity to grip or hold an object between its front paws. Domestic pets will

2

naturally seek to stabilize the subject of their chewing action, allowing for a stronger and more satisfying engagement by the pet's mouth, while increasing the friction applied to the pet's teeth and oral cavity by the bone or chew toy. Another failing of existing products is the inability to use pet toothpaste and other supplementary dental hygiene products in conjunction with the chewing action of the chew toys. This leaves the need for supplementary manual cleaning by the domestic pet owner. Yet another disadvantage of existing products is the lack of differentiated surfaces for inner and outer domestic pet teeth. Domestic pets, such as dogs and cats, have substantially different shape and spacing in their teeth between the front of their mouths, wherein are located canines and other long, large teeth, and the smaller, more closely spaced teeth in the back of the pets' mouths. The differences in size and spacing of these teeth suggest the need for different surfaces with different textures and projections adapted to the particular needs of that portion of the domestic pet's dental structures.

For the foregoing reasons, there is a need for an improved domestic pet chew toy that allows domestic pets to clean their own teeth.

SUMMARY

The present invention is directed to an apparatus that satisfies this need.

One possible embodiment of the invention takes the form of a chew toy for use by a domestic pet such as a dog, cat or other domesticated animal. This embodiment comprises a central member for engagement of a domestic pet's oral cavity, which includes at least one inner surface defining a cavity and an outer surface, each or both of which may have a variety of scrubbing elements affixed to them.

Another possible embodiment comprises a central member for engagement of a domestic pet's oral cavity, said member having a first end and a second end. The second end further comprises one or more projections, which may be circular or otherwise shaped, which are substantially flat and oriented perpendicular to the length of the central member. The projections allow the member to be stood upright and gripped by a domestic pet, using its front paws.

Yet another possible embodiment includes a reservoir running the length of the central member of a chew toy, in which, by way of non-limiting example, flavored toothpaste for domestic pets can be retained. Smaller dispensing holes are present in the central member perpendicular to the reservoir, allowing the toothpaste or other products to be dispensed into the oral cavity of a domestic pet when the central member is engaged by said pet's oral cavity.

BRIEF DESCRIPTION OF THE DRAWINGS

These and other features, aspects, and advantages of the present invention will become better understood with reference to the following description, appended claims, and drawings where:

FIG. 1 shows an embodiment of the invention having a central member with an inner surface defining a cavity, perpendicular stabilizing projections, and a plurality of scrubbing elements on the inner and outer surfaces of the central member.

FIG. 2 shows a side-view of an embodiment of the invention, showing the multiplicity of scrubbing elements projecting from the inner surfaces defining the cavity, and the outer surfaces of the member.

3

FIG. 3 shows an embodiment of the invention wherein the central member has inner surfaces defining two separate cavities.

FIG. 4 shows a top-down view of the embodiment of FIG. 3, with the positioning for an optional additional reservoir to retain pet toothpaste shown at center.

FIG. 5 shows a lengthwise cut-away of the central member of the embodiment of FIG. 3, demonstrating the shape and positioning of the additional reservoir, and smaller perpendicular holes for dispensing toothpaste retained in said reservoir.

FIG. 6 shows a comparison between different possible sizes of an embodiment of the invention.

DETAILED DESCRIPTION

In the Summary above and in the Detailed Description, and the claims below, and in the accompanying drawings, reference is made to particular features of the invention. It is to be understood that the disclosure of the invention in this specification includes all possible combinations of such particular features. For example, where a particular feature is disclosed in the context of a particular aspect or embodiment of the invention, or a particular claim, that feature can also be used, to the extent possible, in combination with and/or in the context of other particular aspects and embodiments of the invention, and in the invention generally.

The term “comprises” and grammatical equivalents thereof are used herein to mean that other components, ingredients, steps, etc. are optionally present. For example, an article “comprising” (or “which comprises”) components A, B, and C can consist of (i.e., contain only) components A, B, and C, or can contain not only components A, B, and C but also one or more other components.

The term “at least” followed by a number is used herein to denote the start of a range beginning with that number (which may be a range having an upper limit or no upper limit, depending on the variable being defined). For example, “at least 1” means 1 or more than 1. The term “at most” followed by a number is used herein to denote the end of a range ending with that number (which may be a range having 1 or 0 as its lower limit, or a range having no lower limit, depending upon the variable being defined). For example, “at most 4” means 4 or less than 4, and “at most 40%” means 40% or less than 40%. When, in this specification, a range is given as “(a first number) to (a second number)” or “(a first number)-(a second number),” this means a range whose lower limit is the first number and whose upper limit is the second number. For example, 25 to 100 mm means a range whose lower limit is 25 mm, and whose upper limit is 100 mm.

In one possible embodiment of the invention, as shown in FIG. 1, takes the form of a chew toy having a central member. The chew toy may be made of any suitable material, including by way of non-limiting example any non-toxic plastic. The central member comprises at least one inner surface, defining a cavity having an open end running the length of the central member and an additional open side at the top end of the central member. Said cavity should be of sufficient depth to allow full penetration by the front or back teeth of a domestic pet. The size of the central member, and therefore relative depth of the cavity, may be varied to suit a variety of domestic pet breeds, as shown in FIG. 6. By providing inner and outer surfaces for contact with the teeth and gums of a domestic pet, faster and more complete cleaning action is achieved on the pet’s teeth and gums by maximizing the area of contact and friction between the

4

central member and the pet’s teeth and gums. In addition, further cleaning action is achieved by the simultaneous contact of the surfaces of the member with the forward and inner teeth of the pet.

As shown in FIG. 2, the outer surface of the central body may have affixed to it a plurality of scrubbing elements. As also shown in FIG. 2, the inner surface defining the cavity may also have affixed to it an additional plurality of scrubbing elements.

The scrubbing elements affixed to the outer and inner surfaces may vary in size and shape. By way of example, they could take the form of bristles, pyramids, cones, rectangles, or any of a variety of other desirable configurations. The scrubbing elements affixed to the outer surface of the central member might, in one possible embodiment, be of a different shape or size than the scrubbing elements affixed to the inner surface, as shown in FIG. 2. Similarly, the size and shape of the scrubbing elements affixed to the inner surface might be the same as those affixed to the outer surface of the central member. This allows the scrubbing elements to be adapted to the differential spacing, tooth shape, and mouth size of a variety of domestic pets.

A further aspect of the present invention is shown in FIG. 1, comprising the substantially flat perpendicular projections. Although the embodiment shown in FIG. 1 has the projections take the form of two flanges or separate extensions, one of skill in the art will understand that the projection or projections can take a variety of shapes and sizes. Non-limiting examples might be a singular projection forming a circular base to the central member, or a multiplicity of flanges allowing a pet to grip the projections from a variety of angles. These projections allow a pet to fully stabilize the chew toy upright using their natural gripping action with the front paws.

In contrast to the rough or knobbed ends of natural bones or typical pet chew toys, here the domestic pet can fully pin down and stabilize the central member of the chew toy such that it is fully upright and immobile. This allows for a much stronger grip on the central body by the mouth of the domestic pet, increasing the friction between the surface of the chew toy and the pet’s teeth. This allows for superior cleaning and removal of plaque, leftover food, and other detrimental material from the mouth of the pet.

Yet a further aspect of the present invention is shown in FIG. 4, showing one possible embodiment of the central reservoir for toothpaste or other substances suitable for dispensing. Here, the opening allows for input of a pet toothpaste or other appropriate substance into the reservoir, which is dispensed through perpendicular holes to the main cavity or cavities of the chew toy. Although in this particular embodiment the reservoir takes a cylindrical form, other embodiments might include one or more reservoirs of different shapes or locations.

Another possible embodiment of the present invention is shown in FIG. 3. Here, the central member comprises two inner surfaces, each defining separate cavities similar to the single cavity shown in FIG. 1. By providing a second cavity, a domestic pet can simultaneously engage not just the forward and rear of the pet’s teeth and gums simultaneously, but on the top and bottom of the pet’s mouth as well.

What is claimed is:

1. A chew toy for pet dental hygiene, comprising:
 - a) a central chewing member,
 - comprising:
 - i) at least two U-shaped grooves that comprise, on at least a portion of all internal surfaces of said at

5

least two U-shaped grooves, a plurality of protruding scrubbing elements;

- a) wherein said at least two U-shaped grooves generally define said central chewing member with a first and second end;
 - b) further wherein said at least two U-shaped grooves are arranged parallel to each other and perpendicular, at said second end, to an at least one bottom stabilizing portion;
 - c) further wherein said at least two U-shaped grooves are each substantially the length of said central chewing member;
 - d) further wherein said at least two U-shaped grooves are positioned on opposing sides of said central chewing member;
 - e) further wherein each said at least two U-shaped grooves is generally U-shaped in cross section across said central chewing member;
 - ii) a plurality of nub shaped elements positioned on an outside surface of said central chewing member,
 - iii) at least one central aperture in said first end of said central chewing member and an at least one longitudinal cavity that begins at said aperture and runs at least a portion of the length of said central chewing member;
 - iv) at least one dispensing hole communicating between said at least one longitudinal cavity and said at least two U-shaped grooves, wherein said at least one dispensing hole is perpendicular to said at least one longitudinal cavity;
- b) said at least one bottom stabilizing portion, comprising:
- i) at least one substantially flat projection that stabilizes said chew toy when in use;
 - ii) wherein said at least one projection is perpendicular to said central chewing member;
 - iii) wherein said at least one bottom stabilizing portion is configured to stabilize said chew toy in an upright position; and
- wherein said chew toy is a unitary structure made of non-toxic material.
2. The chew toy of claim 1, wherein at least one of said at least two U-shaped grooves are sufficiently deep to clean teeth to the gum line.

6

3. The chew toy of claim 1, wherein said protruding scrubbing elements comprise bristles.

4. The chew toy of claim 1, wherein said at least one longitudinal cavity is configured to hold at least one substance.

5. The chew toy of claim 4, wherein said substance comprises toothpaste.

6. The chew toy of claim 1, wherein said at least one dispensing hole is adapted to transfer at least one substance between said at least one longitudinal cavity and said at least two U-shaped grooves.

7. The chew toy of claim 6, wherein said substance comprises toothpaste.

8. The chew toy of claim 1, wherein said pet comprises a dog.

9. The chew toy of claim 1, further wherein said chew toy is operable as a toothbrush for use by pets to brush their own teeth.

10. The chew toy of claim 1, wherein when chew toy is in use, multiple teeth and multiple surfaces of teeth are cleaned.

11. The chew toy of claim 1, wherein said chew toy comprises a single, unitary structure.

12. The chew toy of claim 1, wherein said chew toy comprises natural rubber.

13. A method of promoting pet dental hygiene, comprising:

- a) providing a pet in need of promotion of dental hygiene;
- b) providing a chew toy of claim 1;
- c) allowing said pet to engage with said chew toy; wherein the dental hygiene of said pet is promoted.

14. The method of claim 13,

wherein said chew toy comprises toothpaste.

15. The method of claim 13, wherein said pet comprises a dog.

16. The method of claim 13, wherein at least one of said at least two grooves are sufficiently deep to clean teeth to the gum line.

17. The method of claim 13, wherein when chew toy is in use, multiple teeth and multiple surfaces of teeth are cleaned.

* * * * *

Exhibit 6

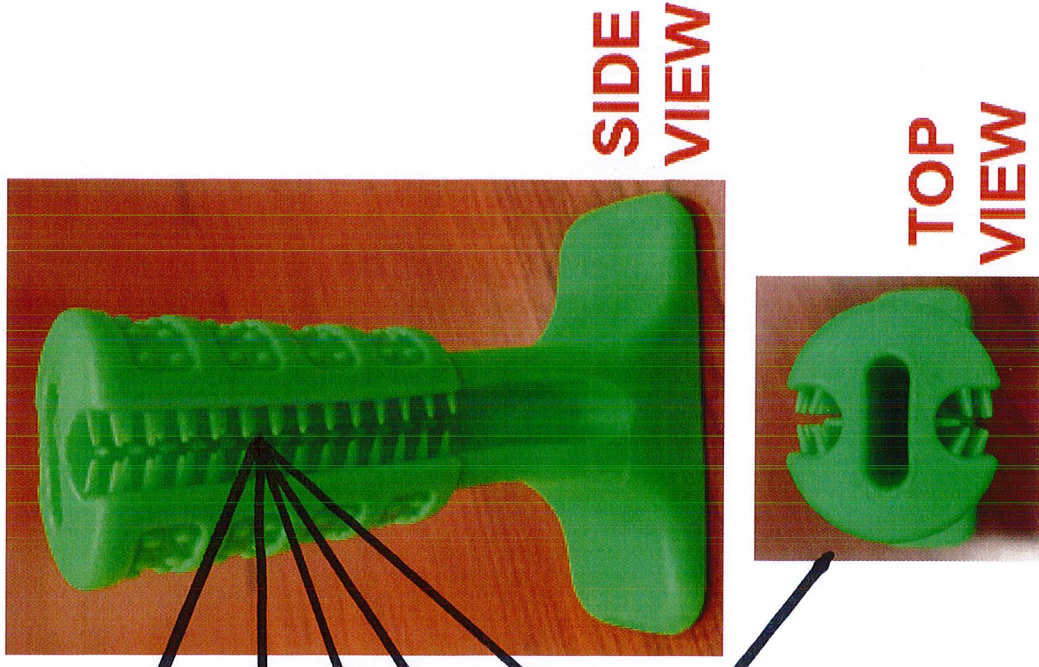
Text of Claim 1

A chew toy for pet dental hygiene, comprising:

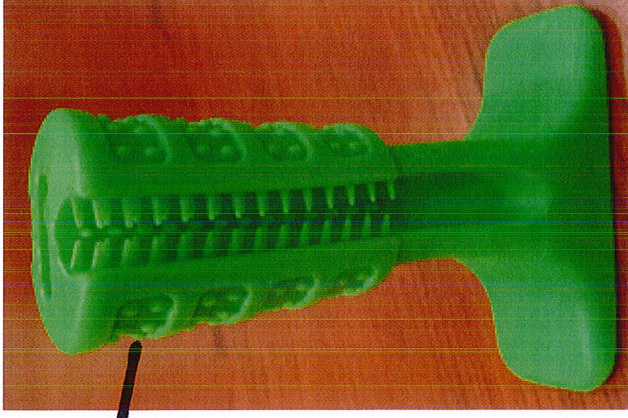
- a) a central chewing member, comprising:
 - i) at least two U-shaped grooves that comprise, on at least a portion of all internal surfaces of said at least two U-shaped grooves, a plurality of protruding scrubbing elements;
 - a) wherein said at least two U-shaped grooves generally define said central chewing member with a first and second end;
 - b) further wherein said at least two U-shaped grooves are arranged parallel to each other and perpendicular, at said second end, to an at least one bottom stabilizing portion;
 - c) further wherein said at least two U-shaped grooves are each substantially the length of said central chewing member;
 - d) further wherein said at least two U-shaped grooves are positioned on opposing sides of said central chewing member;
 - e) further wherein each said at least two U-shaped grooves is generally U-shaped in cross section across said central chewing member;

Type 1 Infringing Product

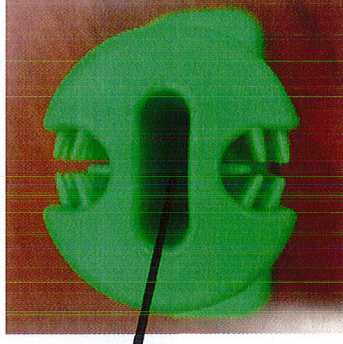
This is the preamble.



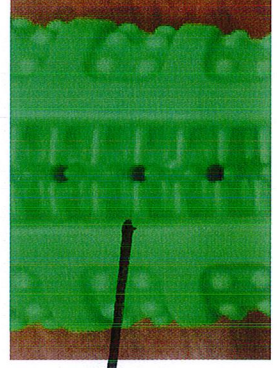
ii) a plurality of nub shaped elements positioned on an outside surface of said central chewing member,



iii) at least one central aperture in said first end of said central chewing member and an at least one longitudinal cavity that begins at said aperture and runs at least a portion of the length of said central chewing member;



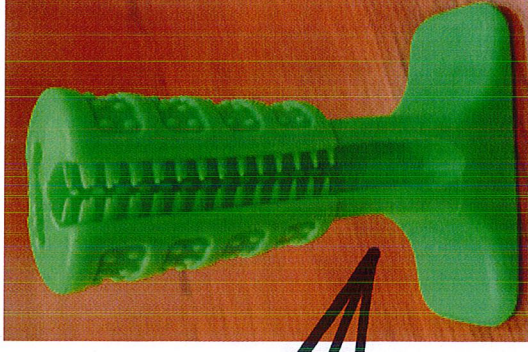
iv) at least one dispensing hole communicating between said at least one longitudinal cavity and said at least two U-shaped grooves, wherein said at least one dispensing hole is perpendicular to said at least one longitudinal cavity;



Type 1 Infringing Product against claim 1 of U.S Patent No. 10,477,838

b) said at least one bottom stabilizing portion, comprising:

- i) at least one substantially flat projection that stabilizes said chew toy when in use;
- ii) wherein said at least one projection is perpendicular to said central chewing member;
- iii) wherein said at least one bottom stabilizing portion is configured to stabilize said chew toy in an upright position; and



wherein said chew toy is a unitary structure made of non-toxic material.

Chew toy is a unitary structure made of non-toxic material.

Exhibit 7

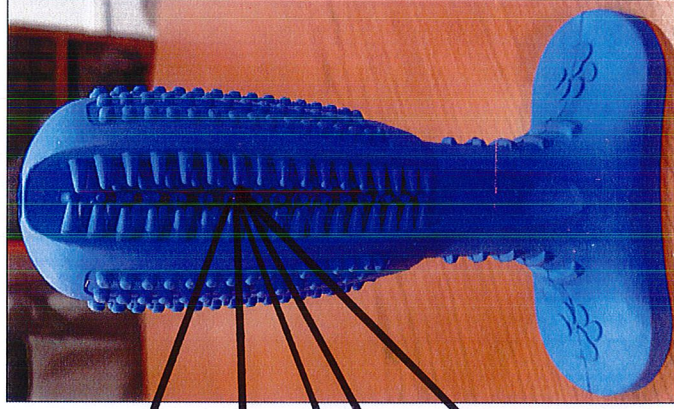
Text of Claim 1

A chew toy for pet dental hygiene, comprising:

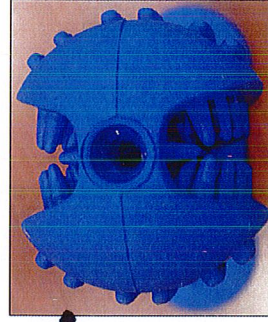
- a) a central chewing member, comprising:
 - i) at least two U-shaped grooves that comprise, on at least a portion of all internal surfaces of said at least two U-shaped grooves, a plurality of protruding scrubbing elements;
 - a) wherein said at least two U-shaped grooves generally define said central chewing member with a first and second end;
 - b) further wherein said at least two U-shaped grooves are arranged parallel to each other and perpendicular, at said second end, to an at least one bottom stabilizing portion;
 - c) further wherein said at least two U-shaped grooves are each substantially the length of said central chewing member;
 - d) further wherein said at least two U-shaped grooves are positioned on opposing sides of said central chewing member;
 - e) further wherein each said at least two U-shaped grooves is generally U-shaped in cross section across said central chewing member;

Type 2 Infringing Product

This is the preamble.

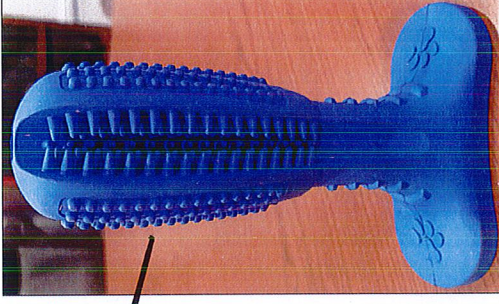


SIDE VIEW

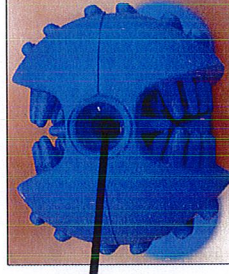


TOP VIEW

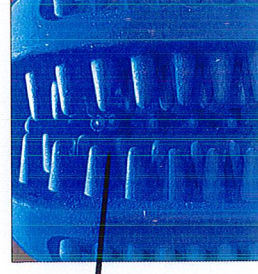
ii) a plurality of nub shaped elements positioned on an outside surface of said central chewing member,



iii) at least one central aperture in said first end of said central chewing member and an at least one longitudinal cavity that begins at said aperture and runs at least a portion of the length of said central chewing member;



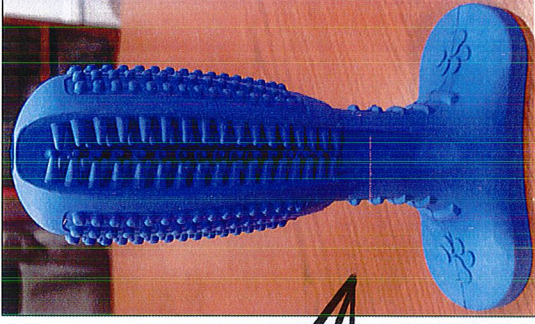
iv) at least one dispensing hole communicating between said at least one longitudinal cavity and said at least two U-shaped grooves, wherein said at least one dispensing hole is perpendicular to said at least one longitudinal cavity;



Type 2 Infringing Product against claim 1 of U.S Patent No. 10,477,838

b) said at least one bottom stabilizing portion, comprising:

- i) at least one substantially flat projection that stabilizes said chew toy when in use;
- ii) wherein said at least one projection is perpendicular to said central chewing member;
- iii) wherein said at least one bottom stabilizing portion is configured to stabilize said chew toy in an upright position; and



wherein said chew toy is a unitary structure made of non-toxic material.

Chew toy is a unitary structure made of non-toxic material.

Exhibit 8

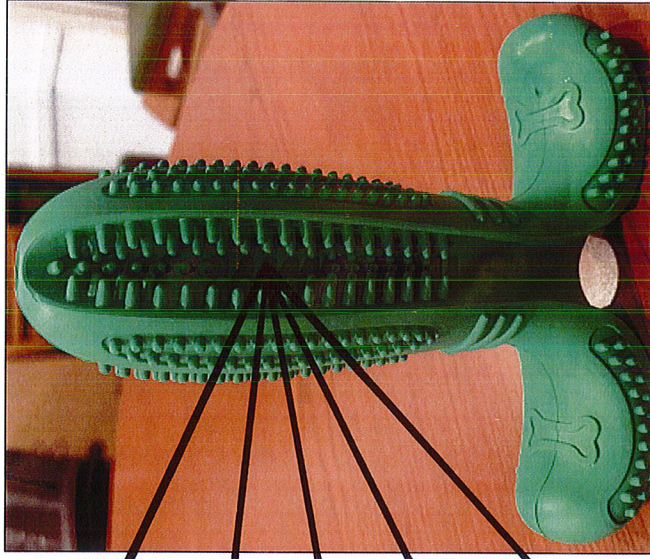
Text of Claim 1

A chew toy for pet dental hygiene, comprising:

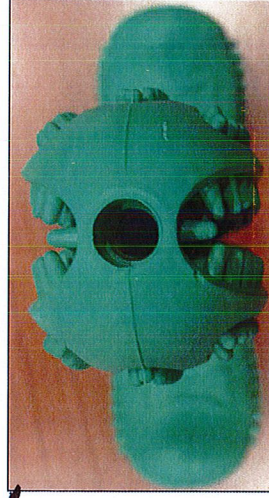
- a) a central chewing member, comprising:
 - i) at least two U-shaped grooves that comprise, on at least a portion of all internal surfaces of said at least two U-shaped grooves, a plurality of protruding scrubbing elements;
 - a) wherein said at least two U-shaped grooves generally define said central chewing member with a first and second end;
 - b) further wherein said at least two U-shaped grooves are arranged parallel to each other and perpendicular, at said second end, to an at least one bottom stabilizing portion;
 - c) further wherein said at least two U-shaped grooves are each substantially the length of said central chewing member;
 - d) further wherein said at least two U-shaped grooves are positioned on opposing sides of said central chewing member;
 - e) further wherein each said at least two U-shaped grooves is generally U-shaped in cross section across said central chewing member;

Type 3 Infringing Product

This is the preamble.



SIDE VIEW

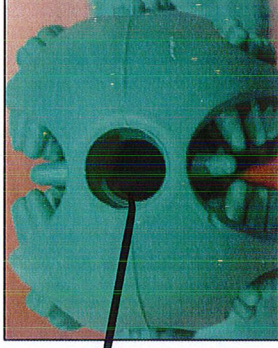


TOP VIEW

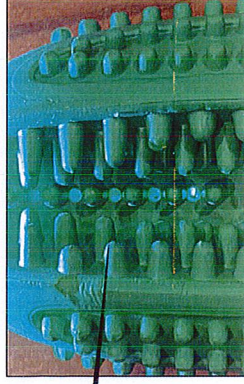
ii) a plurality of nub shaped elements positioned on an outside surface of said central chewing member,



iii) at least one central aperture in said first end of said central chewing member and an at least one longitudinal cavity that begins at said aperture and runs at least a portion of the length of said central chewing member;



iv) at least one dispensing hole communicating between said at least one longitudinal cavity and said at least two U-shaped grooves, wherein said at least one dispensing hole is perpendicular to said at least one longitudinal cavity;



Type 3 Infringing Product against claim 1 of U.S Patent No. 10,477,838

b) said at least one bottom stabilizing portion, comprising:

- i) at least one substantially flat projection that stabilizes said chew toy when in use;
- ii) wherein said at least one projection is perpendicular to said central chewing member;
- iii) wherein said at least one bottom stabilizing portion is configured to stabilize said chew toy in an upright position; and



wherein said chew toy is a unitary structure made of non-toxic material.

Chew toy is a unitary structure made of non-toxic material.

Exhibit 9

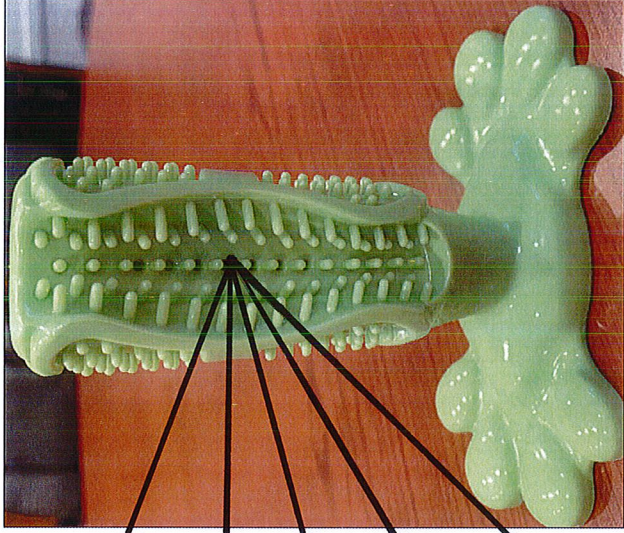
Text of Claim 1

A chew toy for pet dental hygiene, comprising:

- a) a central chewing member, comprising:
 - i) at least two U-shaped grooves that comprise, on at least a portion of all internal surfaces of said at least two U-shaped grooves, a plurality of protruding scrubbing elements;
 - a) wherein said at least two U-shaped grooves generally define said central chewing member with a first and second end;
 - b) further wherein said at least two U-shaped grooves are arranged parallel to each other and perpendicular, at said second end, to an at least one bottom stabilizing portion;
 - c) further wherein said at least two U-shaped grooves are each substantially the length of said central chewing member;
 - d) further wherein said at least two U-shaped grooves are positioned on opposing sides of said central chewing member;
 - e) further wherein each said at least two U-shaped grooves is generally U-shaped in cross section across said central chewing member;

Type 4 Infringing Product

This is the preamble.

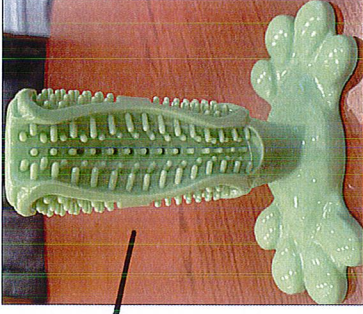


**SIDE
VIEW**



**TOP
VIEW**

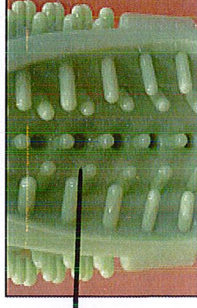
ii) a plurality of nub shaped elements positioned on an outside surface of said central chewing member,



iii) at least one central aperture in said first end of said central chewing member and an at least one longitudinal cavity that begins at said aperture and runs at least a portion of the length of said central chewing member:

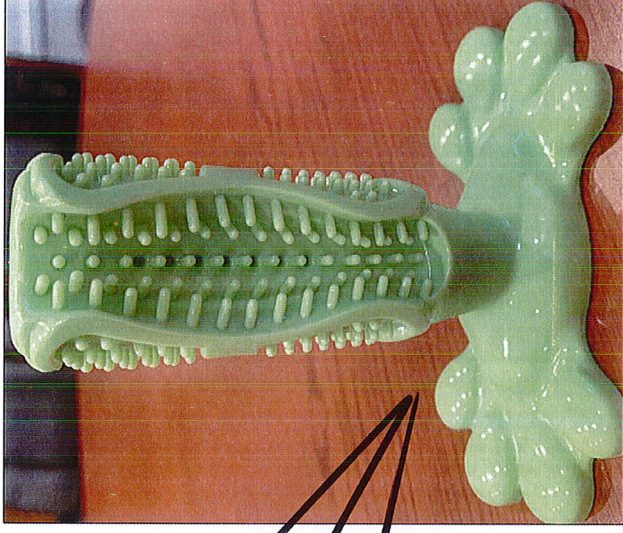


iv) at least one dispensing hole communicating between said at least one longitudinal cavity and said at least two U-shaped grooves, wherein said at least one dispensing hole is perpendicular to said at least one longitudinal cavity;



Type 4 Infringing Product against claim 1 of U.S Patent No. 10,477,838

- b) said at least one bottom stabilizing portion, comprising:
 - i) at least one substantially flat projection that stabilizes said chew toy when in use;
 - ii) wherein said at least one projection is perpendicular to said central chewing member;
 - iii) wherein said at least one bottom stabilizing portion is configured to stabilize said chew toy in an upright position; and



wherein said chew toy is a unitary structure made of non-toxic material.

Chew toy is a unitary structure made of non-toxic material.

Exhibit 10

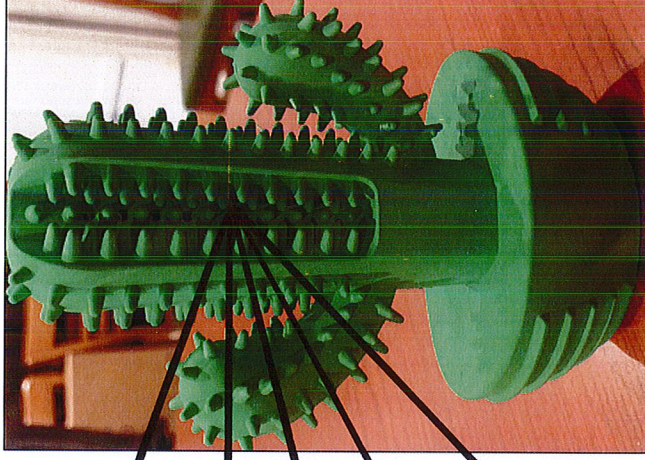
Text of Claim 1

A chew toy for pet dental hygiene, comprising:

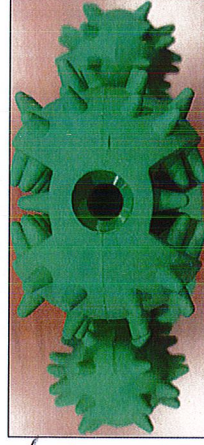
- a) a central chewing member, comprising:
 - i) at least two U-shaped grooves that comprise, on at least a portion of all internal surfaces of said at least two U-shaped grooves, a plurality of protruding scrubbing elements;
- a) wherein said at least two U-shaped grooves generally define said central chewing member with a first and second end;
- b) further wherein said at least two U-shaped grooves are arranged parallel to each other and perpendicular, at said second end, to an at least one bottom stabilizing portion;
- c) further wherein said at least two U-shaped grooves are each substantially the length of said central chewing member;
- d) further wherein said at least two U-shaped grooves are positioned on opposing sides of said central chewing member;
- e) further wherein each said at least two U-shaped grooves is generally U-shaped in cross section across said central chewing member;

Type 5 Infringing Product

This is the preamble.

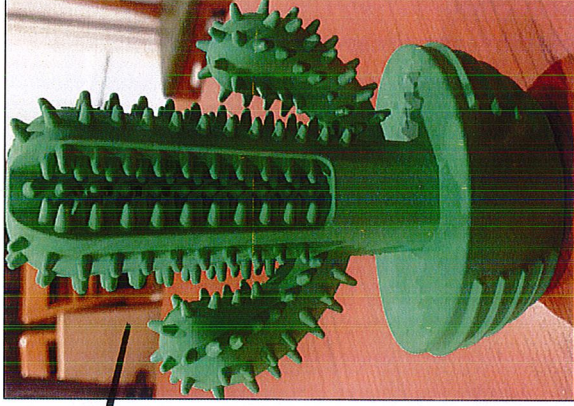


**SIDE
VIEW**

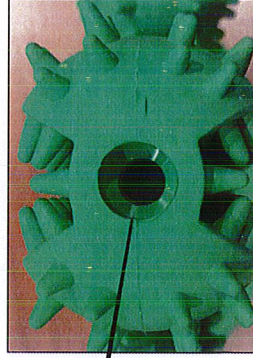


**TOP
VIEW**

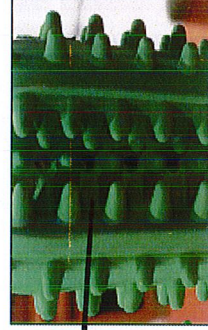
ii) a plurality of nub shaped elements positioned on an outside surface of said central chewing member,



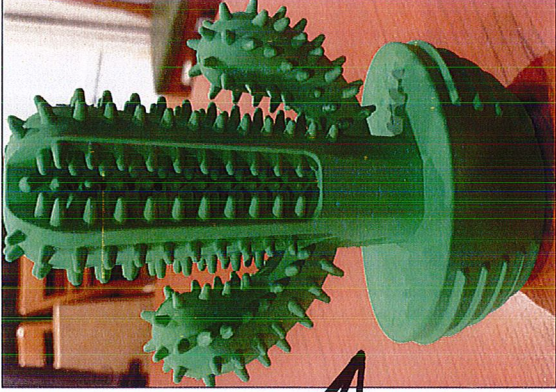
iii) at least one central aperture in said first end of said central chewing member and an at least one longitudinal cavity that begins at said aperture and runs at least a portion of the length of said central chewing member;



iv) at least one dispensing hole communicating between said at least one longitudinal cavity and said at least two U-shaped grooves, wherein said at least one dispensing hole is perpendicular to said at least one longitudinal cavity;



- b) said at least one bottom stabilizing portion, comprising:
 - i) at least one substantially flat projection that stabilizes said chew toy when in use;
 - ii) wherein said at least one projection is perpendicular to said central chewing member;
 - iii) wherein said at least one bottom stabilizing portion is configured to stabilize said chew toy in an upright position; and



wherein said chew toy is a unitary structure made of non-toxic material.

Chew toy is a unitary structure made of non-toxic material.

Exhibit 11

Text of Claim 1

A chew toy for pet dental hygiene, comprising:

a) a central chewing member, comprising:

i) at least two U-shaped grooves that comprise, on at least a portion of all internal surfaces of said at least two U-shaped grooves, a plurality of protruding scrubbing elements;

a) wherein said at least two U-shaped grooves generally define said central chewing member with a first and second end;

b) further wherein said at least two U-shaped grooves are arranged parallel to each other and perpendicular, at said second end, to an at least one bottom stabilizing portion;

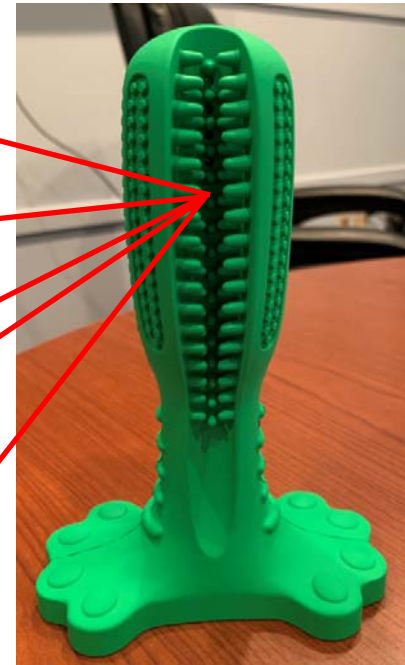
c) further wherein said at least two U-shaped grooves are each substantially the length of said central chewing member;

d) further wherein said at least two U-shaped grooves are positioned on opposing sides of said central chewing member;

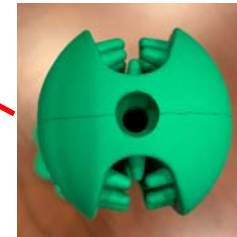
e) further wherein each said at least two U-shaped grooves is generally U-shaped in cross section across said central chewing member;

Type 6 Infringing Product

This is the preamble.



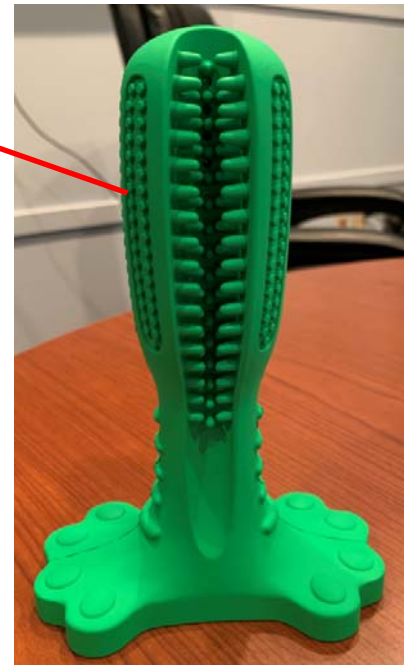
SIDE VIEW



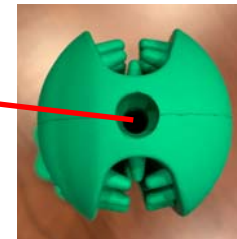
TOP VIEW

Type 6 Infringing Product against claim 1 of U.S Patent No. 10,477,838

ii) a plurality of nub shaped elements positioned on an outside surface of said central chewing member,



iii) at least one central aperture in said first end of said central chewing member and an at least one longitudinal cavity that begins at said aperture and runs at least a portion of the length of said central chewing member;



iv) at least one dispensing hole communicating between said at least one longitudinal cavity and said at least two U-shaped grooves, wherein said at least one dispensing hole is perpendicular to said at least one longitudinal cavity;



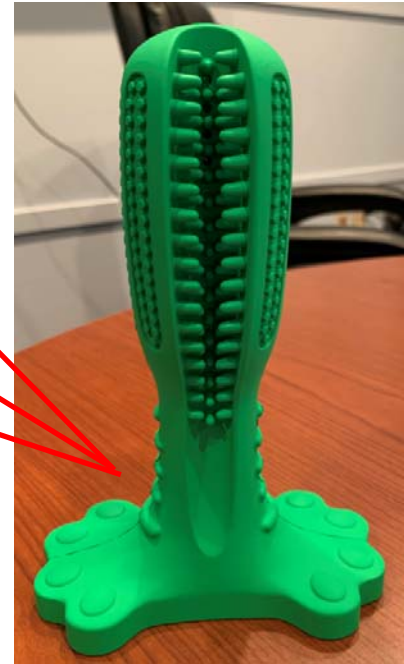
Type 6 Infringing Product against claim 1 of U.S Patent No. 10,477,838

b) said at least one bottom stabilizing portion, comprising:

i) at least one substantially flat projection that stabilizes said chew toy when in use;

ii) wherein said at least one projection is perpendicular to said central chewing member;

iii) wherein said at least one bottom stabilizing portion is configured to stabilize said chew toy in an upright position; and



wherein said chew toy is a unitary structure made of non-toxic material.

Chew toy is a unitary structure made of non-toxic material.