

UNITED STATES DISTRICT COURT
WESTERN DISTRICT OF PENNSYLVANIA

PIKE BRANDS LLC,

Plaintiff,

v.

TEEGEM, BLESSING BABY,
CHAEAMODY, CHUBBY ZEBRA,
DADIOUS, HEATHYBABY, INFANT
SELF, IYOOO, IZZZHH, KIDDAZZLE,
MICOLAN, PANDAEAR, SODEE,
TERMICHY, and TONGXING US,

Defendants.

Civil Action No.

FILED UNDER SEAL

COMPLAINT FOR DAMAGES AND INJUNCTIVE RELIEF

PIKE BRANDS LLC, a Delaware limited liability company (“Plaintiff”), hereby sues Defendants, the Individuals, Partnerships, and Unincorporated Associations identified in the Caption and which are set forth in **Schedule “A”** hereto (collectively “Defendants”). Each of the Defendants has (a) willfully infringed at least one of the Plaintiff’s Design Patents described below; (b) willfully infringed on the Plaintiff’s Trade Dress; and (c) unfairly competing by offering for sale, selling, and distributing knock-off versions of Plaintiff’s Grabease and Nooli brand baby utensils (“Infringing Products”). The Plaintiff therefore brings this Complaint for Design Patent Infringement, Trade Dress Infringement and Unfair Competition seeking money damages and injunctive relief. In support of its claims, Plaintiff alleges as follows:

NATURE OF THE ACTION

1. PIKE BRANDS LLC owns all of the intellectual property arising from and related to the innovative Grabease and Nooli brand baby utensils (as pictured below):



Plaintiff's Grabease Baby Utensils



Plaintiff's Nooli Baby Utensils

2. Defendants have offered for sale, sold, and distributed knock-off versions of the Plaintiff's Products which infringe at least one of Plaintiff's Patents. Moreover, Defendants' sale, distribution, and advertising of the Infringing Products are highly likely to cause consumers to believe that Defendants are offering a genuine version of Plaintiff's Products when they are not.

3. Shown below are the example types of Infringing Products compared to Plaintiff's Products offered for sale by the Defendants:



Plaintiff's Baby Utensils



Defendant chaelmody's Infringing Listing



Defendant TeeGem's Infringing Listing



Defendant Infant Self's Infringing Listing

4. As poorly designed and manufactured products, Defendants' Infringing Products may disappoint a customer who may give the product a bad review.

5. Defendants' Infringing Products are substantially inferior to the genuine product. With poorly designed and manufactured products, Defendants' Infringing Products create serious public safety risks and threaten to destroy the reputation of high quality that Plaintiff's Products have earned.

6. Plaintiff's Products are marketed and advertised extensively including on its websites grabease.com and noolibaby.com and its storefronts on Amazon.com. The unique features of Plaintiff's Products and the manner in which they are marketed and advertised, including the distinct photographs, the design, the instructions, the packaging, and the unique presentation of the product, all comprise Plaintiff's valuable intellectual property ("IP") and all have become distinct in consumer's minds such that consumers associate all of this IP with Plaintiff's Products. Screenshots from Plaintiff's Websites and Amazon Store are attached as Complaint **Exhibit 1**.

7. The innovative features of Plaintiff's Products are protected by numerous design patents as set forth below and more fully described in **Exhibits 2A – 2D** which are true and correct copies of each of the Plaintiff's Patents. Pike Brands owns all of these patents:

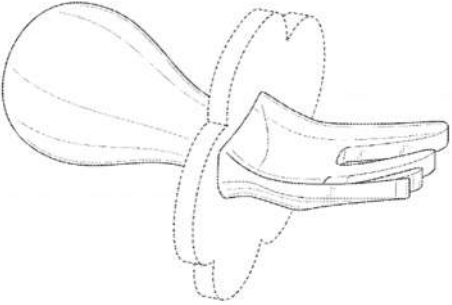
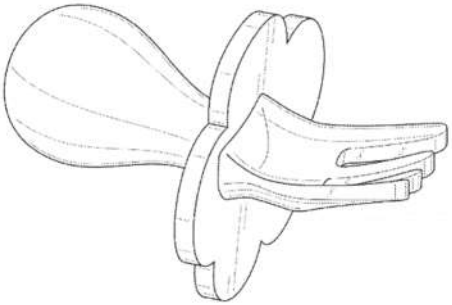
| | | |
|--|---------------------|---|
| <p>U.S. Design Patent No. RE48,520 for TODDLER FORK (the "520 Patent")</p> | <p>TODDLER FORK</p> |  |
| <p>U.S. Design Patent No. RE48,743 for TODDLER FORK (the "743 Patent")</p> | <p>TODDLER FORK</p> |  |
| | | |

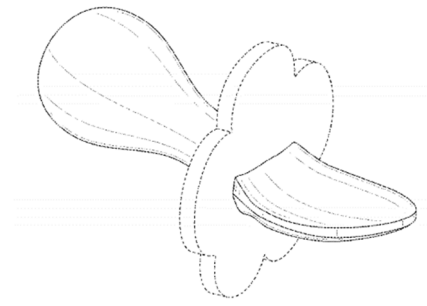
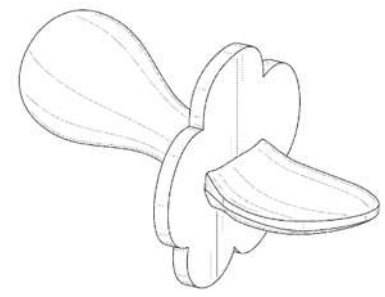
| | | |
|---|----------------------|---|
| <p>U.S. Design Patent No. RE48,531 for TODDLER SPOON (the “531 Patent”)</p> | <p>TODDLER SPOON</p> |  |
| <p>U.S. Design Patent No. 799,280 for TODDLER SPOON (the “280 Patent”)</p> | <p>TODDLER SPOON</p> |  |

Although the ‘531 Patent is a reissue of the ‘280 Patent, the ‘280 Patent has not been surrendered because there remains a pending application for reissue of the ‘280 Patent. Although the ‘743 Patent is a reissue patent, the claims of the ‘743 Patent are substantially similar to those of the original Design Patent D799,910 (“the ‘910 Patent”). Each of the Plaintiff’s Patents covers the unique, novel, and non-obvious ornamental design and appearance of Pike Brands’ baby utensils.

8. On information and belief, Defendants’ sale of Infringing Products gives rise to a plausible expectation that discovery will reveal that Defendants’ actions all arise from the same transaction, occurrence, or series of transactions. Specifically, on information and belief,

Defendants are actively participating in a conspiracy to distribute and sell Infringing Products. For example, Defendants, on information and belief, are working together to manufacture, arrange the manufacture of and/or sell and otherwise distribute the Infringing Products. Moreover, the Infringing Products all infringe on at least one of Plaintiff's Patents. They use common advertising schemes and patterns and sources of their products.

9. Plaintiff therefore brings this action for Patent Infringement under 35 U.S.C. § 271, and The All Writs Act, 28 U.S.C. § 1651(a).

JURISDICTION AND VENUE

10. This Court has jurisdiction over the subject matter of this action pursuant to 15 U.S.C. § 1121 (action arising under the Lanham Act), 28 U.S.C. § 1331 (federal question), 28 U.S.C. § 1338(a) (any Act of Congress relating to patents or trademarks), 28 U.S.C. § 1338(b) (action asserting claim of unfair competition joined with a substantial and related claim under the trademark laws), and 28 U.S.C. § 1367 (supplemental jurisdiction).

11. This Court may exercise personal jurisdiction over a non-resident of the State in which the Court sits to the extent authorized by the state's laws. Fed. R. Civ. P. 4(e). Pennsylvania authorizes personal jurisdiction over each Defendant pursuant to 42 Pa. Cons. Stat. § 5322 (a) which provides in pertinent part: "A tribunal of this Commonwealth may exercise personal jurisdiction over a person ... as to a cause of action or other matter arising from such person: (1) Transacting any business in this Commonwealth. Without excluding other acts which may constitute transacting business for the purpose of this paragraph: (ii) The doing of a single act in this Commonwealth for the purpose of thereby realizing pecuniary benefit ... (3) Causing harm or tortious injury by an act or omission in this Commonwealth. (4) Causing harm

or tortious injury by an act or omission outside this Commonwealth ... (10) Committing any violation within the jurisdiction of the Commonwealth of any statute, home rule charter, local ordinance or resolution, or rule or regulation promulgated thereunder by any government unit or of any order of court or other government unit.” In the alternative, Federal Rule of Civil Procedure 4(k) confers personal jurisdiction over the Defendants because, upon information and belief, Defendants regularly conduct, transact and/or solicit business in Pennsylvania and in this judicial district, and/or derive substantial revenue from their business transactions in Pennsylvania and in this judicial district and/or otherwise avail themselves of the privileges and protections of the laws of the Commonwealth of Pennsylvania such that this Court's assertion of jurisdiction over Defendants does not offend traditional notions of fair play and due process, and/or Defendants’ illegal counterfeiting and infringing actions caused injury to Plaintiff in Pennsylvania and in this judicial district such that Defendants should reasonably expect such actions to have consequences in Pennsylvania and in this judicial district, for example:

a. Upon information and belief, at all times relevant hereto, Defendants were and/or are systematically directing and/or targeting their business activities at consumers in the United States, including Pennsylvania, through on-line platforms with Merchant Storefronts (as defined *infra*), via on-line marketplace websites, such as Amazon.com, under the Seller IDs, as well as any and all as yet undiscovered accounts with Merchant Storefronts held by or associated with Defendants, their respective officers, employees, agents, servants and all persons in active concert or participation with any of them (“User Accounts”), through which consumers in the United States, including Pennsylvania, can view the one or more of Defendants’ Merchant Storefronts that each Defendant operates, uses to communicate with Defendants regarding their listings for Infringing Products and

to place orders for, receive invoices for and purchase Infringing Products for delivery in the U.S., including Pennsylvania, as a means for establishing regular business with the U.S., including Pennsylvania.

b. Upon information and belief, certain Defendants are sophisticated sellers, each operating one or more commercial businesses using their respective User Accounts through which Defendants, their respective officers, employees, agents, servants and all persons in active concert of participation with any of them, operate storefronts to manufacture, import, export, advertise, market, promote, distribute, offer for sale and/or otherwise deal in products, including the Infringing Products, which are held by or associated with Defendants, their respective officers, employees, agents, servants and all persons in active concert or participation with any of them (“Merchant Storefront(s)”) in wholesale quantities at significantly below-market prices to consumers worldwide, including to those in the U.S., and specifically Pennsylvania.

c. Upon information and belief, Defendants’ Merchant Storefronts reflect multiple sales to consumers all over the world, including repeat sales to consumers in the U.S. and into this judicial district.

d. Upon information and belief, all Defendants accept payment in U.S. Dollars and offer shipping to the U.S., including to Pennsylvania.

e. Upon information and belief, at all times relevant, Defendants have transacted business with consumers located in the U.S., including Pennsylvania, for the sale and shipment of Infringing Products.

f. Upon information and belief, some Defendants are employing and benefiting from substantially similar, paid advertising and marketing and advertising strategies in order to make their Merchant Storefronts selling illegal goods appear more relevant and attractive to search result software across an array of search words, including but not limited to “NOOLI”, “GRABEASE”, “TODDLER SPOON”, “TODDLER FORK”, “BABY SPOON”, and “BABY FORK”. By their actions, Defendants are causing concurrent and indivisible harm to Plaintiff and the consuming public by (i) depriving Plaintiff of its right to fairly compete for space within the various on-line marketplace search results and reducing the visibility of the Plaintiff’s Products on various on-line marketplaces and/or diluting and driving down the retail market price for the Plaintiff’s Products (ii) causing an overall degradation of the value of the goodwill associated with Plaintiff’s Products; and (iii) increasing Plaintiff’s overall cost to market its goods and educate consumers about its brand and products.

g. Upon information and belief, Defendants have cooperated, communicated their plans with one another, shared information, and coordinated their efforts, all in order to create an illegal marketplace operating in parallel to the legitimate marketplace of Plaintiff’s and the legally authorized resellers of Plaintiff’s genuine goods.

h. Upon information and belief, Defendants are concurrently targeting their infringing activities toward consumers and causing harm in Allegheny County, Pennsylvania.

i. Upon information and belief, Defendants likely reside and/or operate in foreign jurisdictions with lax trademark and patent enforcement systems and are cooperating by creating an illegal stream of infringing and counterfeit goods.

j. Upon information and belief, Defendants are aware of Plaintiff, its genuine NOOLI and GRABEASE brand baby utensils, and are aware that their illegal infringing actions alleged herein are likely to cause injury to Plaintiff in the United States, in Pennsylvania and in this judicial district specifically, as Plaintiff conducts substantial business in Pennsylvania.

k. Plaintiff is suffering irreparable and indivisible injury and suffered substantial damages as a result of Defendants' unauthorized and wrongful sale of infringing goods.

12. Venue is proper, *inter alia*, pursuant to 28 U.S.C. § 1391 because, for example:

a. Upon information and belief, Defendants conduct, transact, and/or solicit business in this judicial district.

b. Upon information and belief, Defendants or their agent(s) may be found in this district because personal jurisdiction is proper in this district.

c. Upon information and belief, this is a judicial district in which a substantial part of the events or omissions giving rise to the infringement claims occurred, or a substantial part of the property that is the subject of the action is situated.

d. Defendants not resident in the United States may be sued in this judicial district because personal jurisdiction is proper in this district.

THE PLAINTIFF

13. Plaintiff, PIKE BRANDS LLC, is a Delaware limited liability company and has its principal place of business at 113 Cherry Street, PMB 89249, Seattle, Washington 98104-2205 US.

14. Plaintiff is, in part, engaged in the business of manufacturing and distributing throughout the world, including within this district, the NOOLI and GRABEASE baby utensils, through its websites (*See Exhibit 1*), its authorized storefronts on amazon.com, and various retail establishments. Defendants, through the sale and offer to sell Infringing Products are directly, and unfairly, competing with Plaintiff's economic interest in the Commonwealth of Pennsylvania and causing Plaintiff harm within this jurisdiction.

15. Like many other brand owners, Plaintiff suffers ongoing daily and sustained violations of its rights at the hands of infringers, such as Defendants herein, who wrongfully reproduce Plaintiff's Products for the twin purposes of (i) duping and confusing the consuming public and (ii) earning substantial profits from the sale of their Infringing Products. The natural and intended byproduct of Defendants' actions is the erosion and destruction of the goodwill associated with Plaintiff's Products and the destruction of the legitimate market sector in which Plaintiff operates.

16. The recent explosion of counterfeiting and infringement over the Internet, including through online marketplace platforms, has created an environment that requires brand owners, such as Plaintiff, to expend significant time and money across a wide spectrum of efforts in order to protect both consumers and Plaintiff from the ill effects of confusion and the erosion of the goodwill associated with Plaintiff's brand and products.

THE DEFENDANTS

17. The Defendants are individuals and/or business entities of unknown makeup, each of whom, upon information and belief, either reside or operate in foreign jurisdictions, or

(though not foreign)¹ redistribute products from the same or similar sources in those foreign locations. Defendants have the capacity to be sued pursuant to Federal Rule of Civil Procedure 17(b). Defendants target their business activities toward consumers throughout the United States, including within this district, and conduct pervasive business through the operation of, at least, one fully interactive commercial Internet based e-commerce store via, at least one of the Internet based online marketplaces Amazon.com, ebay.com, aliexpress.com, and wish.com, all under the Seller IDs.

18. Upon information and belief, the Defendants use aliases in conjunction with the operation of their businesses as set forth in Schedule “A” hereto.

19. Defendants are the past and present controlling forces behind the sale of products infringing at least one of Plaintiff’s Patents described herein using at least the Seller IDs.

20. Upon information and belief, Defendants were willfully advertising, offering for sale and selling goods infringing upon at least one of Plaintiff’s Patents to consumers within the United States and this district through several fully interactive, commercial Internet websites and Internet based e-commerce stores operating under, at least, the storefronts, the Seller IDs, and any additional domain names, websites and corresponding website URLs or seller identifications and store URL aliases not yet known to Plaintiff. Defendants have purposefully directed some portion of their illegal activities towards consumers in the Commonwealth of Pennsylvania

¹ Prior to filing this lawsuit, Plaintiff viewed a public seller profile that is published by each Defendant’s Amazon.com storefront that purports to identify the name and address of the Defendant. Solely based upon their representation on their Amazon.com storefronts, the following defendants have identified themselves as US-based and are not at this time alleged to be foreign sellers: BLESSING BABY, CHUBBY ZEBRA and PANDAEAR.

through the advertisement, offer to sell, sale, and/or shipment of Infringing Products into the Commonwealth.

21. Defendants have registered, established or purchased, and maintained the on-line marketplace website storefronts and Seller IDs. Upon information and belief, Defendants have engaged in fraudulent conduct with respect to the registration of the storefronts and Seller IDs by providing false and/or misleading information to the Internet based e-commerce platforms where they offer for sale and/or sell, during the registration or maintenance process related to their respective Seller ID. Upon information and belief, Defendants have anonymously registered and maintained some of the Seller IDs for the sole purpose of engaging in illegal infringing activities.

22. Upon information and belief, Defendants will continue to register or acquire new seller identification aliases for the purpose of selling and offering for sale goods infringing at least one of Plaintiff's Patents unless preliminarily and permanently enjoined.

23. Defendants' Internet-based businesses amount to nothing more than illegal operations established and operated in order to infringe the intellectual property rights of Plaintiff.

24. Defendants' business names, i.e., the Seller IDs, associated payment accounts, and any other alias seller identification names used in connection with the sale of goods infringing on at least one of Plaintiff's Patents are essential components of Defendants' online activities and are the means by which Defendants further their infringement scheme and cause harm to Plaintiff.

COMMON FACTUAL ALLEGATIONS

Plaintiff's Innovative Grabease and Nooli Brand Baby Utensils

25. The Plaintiff's innovative Grabease and Nooli brand baby utensils were created with a baby in mind. All of the combined features did not exist until these utensils were brought to market. The idea was to promote a baby's safe and independent feeding. Thus, the utensils are of a size and shape that is perfect for the baby's grip. They help strengthen the baby's fingers by promoting grip while facilitating hand-to-mouth feeding motion. The combination of the short handle and the built-in choke protection barrier prevent the baby from putting the utensil too far into its mouth. The utensils are recommended by Occupational Therapists because they help the baby develop fine and gross motor skills, getting them ready to color, draw, and write in the months to come. The products are sold by Plaintiff under the brand names Grabease and Nooli ("Plaintiff's Product") and retail for between \$8.95 and \$13.95:



26. The Plaintiff's Patents have never been assigned or licensed to any of the Defendants in this matter. Plaintiff has provided constructive notice of the Plaintiff's Patents by

placing the patent number of the patent on the packaging of Plaintiff's Products and/or on its websites.

27. Plaintiff's Products have been featured in videos or articles by numerous media outlets, including:

10 Essentials for Traveling with Infants - <https://www.tlcme.com/stuff-we-love/essentials-for-traveling-with-infants>

42 Products You Didn't Know You've Been Dreaming Of - <https://www.buzzfeed.com/malloryannp/products-didnt-know-been-dreaming-of>

Valentines Day Gifts for Kids 2020 - <https://consumerqueen.com/lifestyle/valentines-day-gifts-for-kids-2020>

Save Me Steve: Baby Safety Products - <https://www.fox4news.com/video/606259>

Toddler Feeding Essentials: 18 Months - <https://www.eatsleepwear.com/2020/02/18/toddler-feeding-essentials-18-months/>

I'm Going to Spain with a 1-Year-Old and This is What I'm Packing - <https://www.purewow.com/travel/spain-packing-list-with-kids>

The Best Baby & Toddler Feeding Tools of 2021 - <https://redtri.com/best-feeding-tools-and-utensils/slide/8>

Meet the Makers: Getting to Know Grabease Founder Maya Shalev - <https://babiesandtots.macaronikid.com/articles/5f17b22240430c50f98b4e59/meet-the-makers:-getting-to-know-grabease-founder-maya-shalev>

Best Plates, Placemats and Utensils for Toddlers -

<https://www.parenting.com/toddler/gear/best-plates-placemats-and-utensils-for-toddlers/>

These Gifts That Give Back Will Remind You What The Holidays Are All About -

<https://www.romper.com/p/10-holiday-gifts-that-give-back-this-holiday-season-because-giving-twice-is-even-more-nice-13211151>

StrollerTraffic Round-Up: 10 Mealtime Must-Haves for Baby -

[https://babiesandtots.macaronikid.com/articles/5dc1bd8759510a057bf92106/strollertraffi](https://babiesandtots.macaronikid.com/articles/5dc1bd8759510a057bf92106/strollertraffic-round-up-10-mealtime-must-haves-for-baby)
[c-round-up-10-mealtime-must-haves-for-baby](https://babiesandtots.macaronikid.com/articles/5dc1bd8759510a057bf92106/strollertraffi)

Baby Must Haves - <https://famadillo.com/baby-must-haves/>

Toys That Will Grow with Your Tot - <https://www.tlcme.com/stuff-we-love/toys-that-will-grow-with-your-tot>

Best Baby Spoons - <https://www.whattoexpect.com/baby-products/nursing-feeding/best-baby-spoons/>

Favorite Products for Baby-to-Toddler Feeding -

<https://consumerqueen.com/lifestyle/valentines-day-gifts-for-kids-2020>

Open wide! The 15 Best Baby Feeding Spoons That Will Simplify the Transition to

Solids - <https://www.scarymommy.com/spotted/best-baby-feeding-spoons/>

Best Teethers - <https://www.lucieslist.com/guides/introduction-teething/best-teethers/>

Best Baby Spoons - <https://www.whattoexpect.com/baby-products/nursing-feeding/best-baby-spoons/>

Defendants' Wrongful and Infringing Conduct

28. Upon information and belief, Defendants are, through at least the Internet based e-commerce stores operating under the Seller IDs, promoting, selling, offering for sale and distributing goods that willfully infringe at least one of Plaintiff's Patents and Plaintiff's Trade Dress while marketing their knock-off products in a willful attempt to pass off their knock-off products as the genuine version of Plaintiff's Products.

29. Upon information and belief, Defendants' Infringing Products are of a quality substantially and materially different than that of Plaintiff's genuine goods. Defendants, upon information and belief, are actively using, promoting and otherwise advertising, distributing, selling, and/or offering for sale substantial quantities of their Infringing Products with the knowledge and intent that such goods will be mistaken for the genuine high quality goods offered for sale by Plaintiff despite Defendants' knowledge that they are without authority to use the subject matter of the Plaintiff's Patents.

30. Defendants advertise their Infringing Products for sale to the consuming public via Internet based e-commerce stores on, at least, one Internet marketplace using at least the Seller IDs. In so advertising these goods, Defendants improperly and unlawfully infringe at least one of Plaintiff's Patents without Plaintiff's permission.

31. As part of their overall infringement scheme, Defendants are, upon information and belief, concurrently employing and benefitting from substantially similar, advertising and marketing strategies based, in large measure, upon an illegal use of infringements of the Plaintiff's Patents in order to make their e-commerce stores selling illegal goods appear more relevant and attractive to consumers online. By their actions, Defendants are contributing to the

creation and maintenance of an illegal marketplace operating in parallel to the legitimate marketplace for Plaintiff's genuine goods. Defendants are causing, individual, concurrent and indivisible harm to Plaintiff and the consuming public by (i) depriving Plaintiff and other third parties of their right to fairly compete for space within search engine results and reducing the visibility of Plaintiff's genuine goods on the World Wide Web, (ii) causing actual consumer confusion, (iii) harm to Plaintiff's reputations, including tarnishing their status as the innovator in this market, (iv) an overall degradation of the value of the goodwill associated with the Plaintiff's brand, and (v) increasing Plaintiff's overall cost to market its goods and educate consumers about its brand via the Internet.

32. Plaintiff confirmed that Defendants were and/or are still currently offering for sale and/or selling Infringing Products for sale to the consuming public via Internet based e-commerce stores on, at least, one Internet marketplace using at least the Seller IDs and that Defendants provide shipping and/or have actually shipped Infringing Products to customers located within this judicial district.

33. There is no question that the Infringing Products themselves and the manner in which they are marketed are designed to confuse and mislead consumers into believing that they are purchasing Plaintiff's Products or that the Infringing Product is otherwise approved by or sourced from Plaintiff, thereby trading on the goodwill and reputation of Plaintiff.

34. Upon information and belief, at all times relevant hereto, Defendants in this action had full knowledge of Plaintiff's ownership of the Plaintiff's Patents. Defendants' use of the patent is without Plaintiff's consent or authorization.

35. Defendants are engaging in the above-described illegal infringing activities knowingly and intentionally or with reckless disregard or willful blindness to Plaintiff's rights for the purpose of infringing the Plaintiff's Patent and trading on Plaintiff's goodwill and reputation. If Defendants' intentional infringing activities are not preliminarily and permanently enjoined by this Court, Plaintiff and the consuming public will continue to be harmed.

36. Defendants' above identified infringing activities are likely to cause confusion, deception, and mistake in the minds of consumers before, during, and after the time of purchase. Moreover, Defendants' wrongful conduct is likely to create a false impression and deceive customers, the public, and the trade into believing there is a connection or association between Plaintiff's Products and Defendants' Infringing Products, which there is not.

37. Upon information and belief, Defendants' payment and financial accounts are being used by Defendants to accept, receive, and deposit profits from Defendants' infringing activities connected to their Seller IDs and any other alias e-commerce stores, photo albums, seller identification names, domain names, or websites being used and/or controlled by them.

38. Further, upon information and belief, Defendants are likely to transfer or secret their assets to avoid payment of any monetary judgment awarded to Plaintiff.

39. Plaintiff has no adequate remedy at law.

40. Plaintiff is suffering irreparable injury and have suffered substantial damages as a result of Defendants' unauthorized and wrongful infringement of at least one of Plaintiff's Patents. If Defendants' infringing activities are not preliminarily and permanently enjoined by this Court, Plaintiff and the consuming public will continue to be harmed.

41. The harm and damages sustained by Plaintiff has been directly and proximately caused by Defendants' wrongful reproduction, use, advertisement, promotion, offers to sell, and sale of their Infringing Products.

The Scope of Defendants' Activities

42. Upon information and belief, each Defendant operates more than one merchant storefront.

43. Upon information and belief, each Defendant operates merchant storefronts across multiple e-commerce marketplaces.

44. Upon information and belief, each Defendant has sold more than 150,000 units of the Infringing Product.

45. Upon information and belief, each Defendant's profits from the sale of the Infringing Products totals more than \$100,000.

46. Upon information and belief, each Defendant's profits from the sale of the Infringing Products totals more than \$300,000.

47. Upon information and belief, each Defendant's profits from the sale of the Infringing Products totals more than \$2,000,000.

COUNT I – PATENT INFRINGEMENT (35 U.S.C. § 271 (a))
INFRINGEMENT OF THE ‘520 PATENT
PLAINTIFF VS. CERTAIN DEFENDANTS²

48. The allegations in the above paragraphs are hereby incorporated by reference.

49. Plaintiff owns each of the patents in **Exhibits 2A – 2D**. The Plaintiff’s Products are marked in accordance with the Patent Act.

50. Each of the Defendants Products infringe at least the ‘520 Patent.

51. Each of the Defendants have infringed and continue to infringe at least the Plaintiff’s ‘520 Patent, either directly or indirectly through acts of contributory infringement or inducement in violation of 35 U.S.C. § 271, by making, using, selling, importing and/or offering to sell Infringing Products, namely the knock-offs that infringe at least one of Plaintiff’s Patents.

52. Defendants’ infringement, contributory infringement and/or inducement to infringe has injured Plaintiff and they, therefore, is entitled to recover damages adequate to compensate it for such infringement, but in no event less than a reasonable royalty.

53. Defendants’ infringement, contributory infringement and/or inducement to infringe has been willful and deliberate because Defendants have notice of or knew of the Plaintiff’s Patents and have nonetheless injured and will continue to injure Plaintiff, unless and until this Court enters an injunction, which prohibits further infringement and specifically enjoins further manufacture, use, sale, importation and/or offer for sale of products or services that come within the scope of the Plaintiff’s Patents.

² Two of the Defendants, SODEE and TONGXING US were selling devices that only infringed on the ‘280 and ‘531 Patents, thus they are not named in this count.

54. Based on Defendants' wrongful conduct, Plaintiff is entitled to injunctive relief as well as monetary damages and other remedies as provided by the Patent Act, including damages that Plaintiff has sustained and will sustain as a result of Defendants' illegal and infringing actions as alleged herein, enhanced discretionary damages and reasonable attorneys' fees and costs.

COUNT II – PATENT INFRINGEMENT (35 U.S.C. § 271 (a))
INFRINGEMENT OF THE '743 PATENT
PLAINTIFF VS. CERTAIN DEFENDANTS³

55. The allegations in the above paragraphs are hereby incorporated by reference.

56. The allegations in the above paragraphs are hereby incorporated by reference.

57. Plaintiff owns each of the patents in **Exhibits 2A – 2D**. The Plaintiff's Products are marked in accordance with the Patent Act.

58. Each of the Certain Defendants Products infringe at least Plaintiff's '743 Patent.

59. Each of the Certain Defendants have infringed and continue to infringe at least the Plaintiff's '743 Patent either directly or indirectly through acts of contributory infringement or inducement in violation of 35 U.S.C. § 271, by making, using, selling, importing and/or offering to sell Infringing Products, namely the knock-offs that infringe at least THE Plaintiff's '743 Patent.

³ Two of the Defendants, SODEE and TONGXING US were selling devices that only infringed on the '280 AND '531 Patents, thus they are not named in this count.

60. Defendants' infringement, contributory infringement and/or inducement to infringe has injured Plaintiff and they, therefore, is entitled to recover damages adequate to compensate it for such infringement, but in no event less than a reasonable royalty.

61. Defendants' infringement, contributory infringement and/or inducement to infringe has been willful and deliberate because Defendants have notice of or knew of the Plaintiff's Patents and have nonetheless injured and will continue to injure Plaintiff, unless and until this Court enters an injunction, which prohibits further infringement and specifically enjoins further manufacture, use, sale, importation and/or offer for sale of products or services that come within the scope of the Plaintiff's Patents.

62. Based on Defendants' wrongful conduct, Plaintiff is entitled to injunctive relief as well as monetary damages and other remedies as provided by the Patent Act, including damages that Plaintiff has sustained and will sustain as a result of Defendants' illegal and infringing actions as alleged herein, enhanced discretionary damages and reasonable attorneys' fees and costs.

COUNT III – PATENT INFRINGEMENT (35 U.S.C. § 271 (a))
INFRINGEMENT OF THE '531 PATENT
PLAINTIFF VS. ALL DEFENDANTS

63. The allegations in the above paragraphs are hereby incorporated by reference.

64. Plaintiff owns each of the patents in **Exhibits 2A – 2D**. The Plaintiff's Products are marked in accordance with the Patent Act.

65. Each of the Certain Defendants' Products infringe the '531 Patent as demonstrated in Composite Exhibit.

66. Each of the Defendants have infringed and continue to infringe at least the Plaintiff's '531 Patent either directly or indirectly through acts of contributory infringement or inducement in violation of 35 U.S.C. § 271, by making, using, selling, importing and/or offering to sell Infringing Products, namely the knock-offs that infringe at least the Plaintiff's '531 Patent.

67. Defendants' infringement, contributory infringement and/or inducement to infringe has injured Plaintiff and they, therefore, is entitled to recover damages adequate to compensate it for such infringement, but in no event less than a reasonable royalty.

68. Defendants' infringement, contributory infringement and/or inducement to infringe has been willful and deliberate because Defendants have notice of or knew of the Plaintiff's Patents and have nonetheless injured and will continue to injure Plaintiff, unless and until this Court enters an injunction, which prohibits further infringement and specifically enjoins further manufacture, use, sale, importation and/or offer for sale of products or services that come within the scope of the Plaintiff's Patents.

69. Based on Defendants' wrongful conduct, Plaintiff is entitled to injunctive relief as well as monetary damages and other remedies as provided by the Patent Act, including damages that Plaintiff has sustained and will sustain as a result of Defendants' illegal and infringing actions as alleged herein, enhanced discretionary damages and reasonable attorneys' fees and costs.

**COUNT IV – PATENT INFRINGEMENT (35 U.S.C. § 271 (a))
INFRINGEMENT OF THE '280 PATENT
PLAINTIFF VS. ALL DEFENDANTS**

70. The allegations in the above paragraphs are hereby incorporated by reference.

71. Plaintiff owns each of the patents in **Exhibits 2A – 2D**. The Plaintiff's Products are marked in accordance with the Patent Act.

72. Each of the Certain Defendants' Products infringe the '280 Patent as demonstrated in Composite Exhibit.

73. Each of the Defendants have infringed and continue to infringe at least the Plaintiff's '280 Patent either directly or indirectly through acts of contributory infringement or inducement in violation of 35 U.S.C. § 271, by making, using, selling, importing and/or offering to sell Infringing Products, namely the knock-offs that infringe at least the Plaintiff's '280 Patent.

74. Defendants' infringement, contributory infringement and/or inducement to infringe has injured Plaintiff and they, therefore, is entitled to recover damages adequate to compensate it for such infringement, but in no event less than a reasonable royalty.

75. Defendants' infringement, contributory infringement and/or inducement to infringe has been willful and deliberate because Defendants have notice of or knew of the Plaintiff's Patents and have nonetheless injured and will continue to injure Plaintiff, unless and until this Court enters an injunction, which prohibits further infringement and specifically enjoins further manufacture, use, sale, importation and/or offer for sale of products or services that come within the scope of the Plaintiff's Patents.

76. Based on Defendants' wrongful conduct, Plaintiff is entitled to injunctive relief as well as monetary damages and other remedies as provided by the Patent Act, including damages that Plaintiff has sustained and will sustain as a result of Defendants' illegal and infringing actions as alleged herein, enhanced discretionary damages and reasonable attorneys' fees and costs.

**COUNT V: TRADE DRESS INFRINGEMENT AND UNFAIR COMPETITION
PLAINTIFF VS. ALL THE DEFENDANTS**

77. The allegations of the above paragraphs are hereby incorporated by reference.

78. The Defendants have made and sold in interstate commerce baby utensils that embody Plaintiff's trade dress.

79. As a result of the Defendants' conduct as set forth herein, consumers could be confused and induced to purchase the Defendants' baby utensils, mistakenly believing them to be Plaintiff's baby utensils, thus depriving Plaintiff of the profits of sale.

80. The Defendants' baby utensils are of inferior quality to the Plaintiff's baby utensils. As a result of the Defendants' conduct as set forth herein, consumers may come to attribute the inferior qualities of the Defendants' baby utensils to the Plaintiff's baby utensils, to Plaintiff's detriment.

81. By engaging in the conduct set forth herein, the Defendants are passing off their baby utensils as Plaintiff's baby utensils, trading off and exploiting Plaintiff's reputation and goodwill, to Plaintiff's detriment.

82. By engaging in the conduct set forth herein, the Defendants have infringed and continue to infringe Plaintiff's rights in its trade dress, in violation of § 43(a) of the Lanham Act, 15 U.S.C. § 1125(a). The Defendants' conduct is likely to cause confusion – initially, post-sale, and otherwise – mistake, and deception among consumers as to the affiliation, connection, or association of the Defendants with Plaintiff and as to the origin, sponsorship, and approval of the Defendants' baby utensils and commercial activities by Plaintiff. Such conduct also interferes with Plaintiff's right to use its trade dress to identify Plaintiff as the single source of the

Plaintiff's baby utensils. The Defendants' conduct as set forth herein also constitutes false designation of origin, unfair competition, and false advertising in violation of § 43(a) of the Lanham Act, 15 U.S.C. § 1125(a).

83. The Defendants' conduct as set forth herein is wrongful, malicious, fraudulent, deliberate, willful, and/or intentional.

84. The Defendants' conduct as set forth herein is wrongful, malicious, fraudulent, deliberate, willful, and/or intentional and has caused and will continue to harm the Plaintiff.

85. Unless restrained, the Defendants' conduct has caused and will continue to cause irreparable harm to Plaintiff for which they have no adequate remedy at law.

86. The Plaintiff is entitled to an injunction to be made permanent upon entry of a final judgment, preventing the Defendants from continuing the acts complained of herein.

COUNT VI: COMMON LAW UNFAIR COMPETITION

87. The allegations of the above paragraphs are hereby incorporated by reference.

88. The Defendants' conduct as set forth herein is likely to cause consumer confusion, to cause mistake, and to deceive as to the affiliation, connection, or association of the Defendants with Plaintiff and as to the origin, sponsorship, and approval of the Defendants' baby utensils and commercial activities by Plaintiff. Such conduct also interferes with Plaintiff's right to use its trade dress to identify Plaintiff as the single source of the Plaintiff's baby utensils.

89. The Defendants' conduct as set forth herein constitutes unfair competition and palming off.

90. The Defendants' conduct as set forth herein is wrongful, malicious, fraudulent, deliberate, willful, and/or intentional.

91. The Defendants' conduct as set forth herein is wrongful, malicious, fraudulent, deliberate, willful, and/or intentional and has caused and will continue to harm the Plaintiff.

92. Unless restrained, the Defendants' conduct has caused and will continue to cause irreparable harm to Plaintiff for which it has no adequate remedy at law.

93. The Plaintiff is entitled to a preliminary injunction to be made permanent upon entry of a final judgment, preventing the Defendants from continuing the acts complained of herein.

PRAYER FOR RELIEF

WHEREFORE, Plaintiff demands judgment on all Counts of this Complaint and an award of equitable relief and monetary relief against Defendants as follows:

a. A judgment declaring that:

1. All of the Defendants except SODEE and TONGXING US infringed the Plaintiff's '520 Patent.

2. All of the Defendants except SODEE and TONGXING US infringed the Plaintiff's '910 Patent.

3. All of the Defendants infringed the Plaintiff's '531 Patent.

4. All of the Defendants have infringed the Plaintiff's '280 Patent.

b. Entry of temporary, preliminary and permanent injunctions pursuant to 35 U.S.C. § 283, and Federal Rule of Civil Procedure 65 enjoining Defendants, their agents, representatives,

servants, employees, and all those acting in concert or participation therewith, from manufacturing or causing to be manufactured, importing, advertising or promoting, distributing, selling or offering to sell their Infringing Products;

c. Entry of an Order that, upon Plaintiff's request, any Internet marketplace website operators and/or administrators that are provided with notice of the injunction, including but not limited to the online marketplaces Amazon.com, ebay.com, aliexpress.com, and wish.com, identify any e-mail address known to be associated with Defendants' respective Seller ID, and cease facilitating access to any or all e-commerce stores through which Defendants engage in the promotion, offering for sale, and/or sale of Infringing Products.

d. Entry of an Order that, upon Plaintiff's request, any Internet marketplace website operators and/or administrators who are provided with notice of the injunction, including but not limited to the online marketplaces Amazon.com, ebay.com, aliexpress.com, and wish.com, permanently remove any and all listings offering for sale Infringing Products via the e-commerce stores operating under the Seller IDs, including any and all listings linked to the same seller or linked to any other alias seller identification name being used and/or controlled by Defendants to promote, offer for sale and/or sell Infringing Products.

e. Entry of an Order that, upon Plaintiff's request, any Internet marketplace website operators and/or administrators who are provided with notice of the injunction, including but not limited to the online marketplaces Amazon.com, ebay.com, aliexpress.com, and wish.com, immediately cease fulfillment of and sequester all goods of each Defendant or other Seller under a Seller ID offering for sale the Infringing Product in its inventory, possession, custody, or control, and surrender those goods to Plaintiff.

f. Entry of an order awarding Plaintiff damages adequate to compensate for the infringement of its patents, but in no event less than a reasonable royalty for the use made of the invention by the Defendants, together with interest and costs as fixed by the Court pursuant to 35 U.S.C. § 284 and that the award be trebled as provided for under 35 U.S.C. §284.

g. Entry of an Order awarding Plaintiff damages sustained as a result of the Defendants' unlawful infringement of Plaintiff's trade, together with interest on such damages and that such damages be trebled;

h. Entry of an Order awarding Plaintiff an accounting and disgorgement of all profits derived by the Defendants from the sale of goods by the direct or indirect use of the Plaintiff's trade dress or colorable imitations thereof, and that such profits be trebled;

i. Entry of an Order awarding Plaintiff all damages sustained by Plaintiff on account of patent infringement, trade dress infringement, unfair competition in violation of § 43(a) of the Lanham Act, 15 U.S.C. § 1125(a) and common law, and any other damages suffered by Plaintiff as a result of the Defendants' conduct as set forth herein, and that such damages be trebled;

j. Entry of an Order finding that this case is exceptional and an award to Plaintiff of its attorney fees and costs as provided by for under 35 U.S.C. § 285.

k. Entry of an Order that, upon Plaintiff's request, any financial institutions, payment processors, banks, escrow services, money transmitters, including, but not limited to, Zhejiang Ant Small and Micro Financial Services Group Co., Ltd. AliPay (China) Internet Technology

Co. Ltd., and Alipay.com Co., Ltd. (collectively referred to as “AliPay”)⁴, Amazon Payments, Inc., PayPal, Inc. d/b/a paypal.com, and Context Logic, Inc. d/b/a wish.com, or marketplace platforms, including but not limited to, Amazon.com, ebay.com, aliexpress.com, and Context Logic, Inc d/b/a wish.com, and their related companies and affiliates, identify and restrain all funds, up to and including the total amount of judgment, in all financial accounts and/or sub-accounts used in connection with the Seller IDs or other domain names, alias seller identification names, or e-commerce store names or store URLs used by Defendants presently or in the future, as well as any other related accounts of the same customer(s) and any other accounts which transfer funds into the same financial institution account(s), to be surrendered to Plaintiff in partial satisfaction of the monetary judgment entered herein.

- l. Entry of an award of pre- and post-judgment interest on the judgment amount.
- m. Entry of an order for any further relief as the Court may deem just and proper.

⁴ WorldPay US, Inc. (“WorldPay”) processes transactions on behalf of Alibaba and Alipay, which may appear as “Aliexpress” on a cardholder’s credit card statement.

DEMAND FOR JURY TRIAL

Plaintiff respectfully demand a trial by jury on all claims.

Respectfully submitted,

Dated: January 31, 2022

/s/ Stanley D. Ference III

Stanley D. Ference III

Pa. ID No. 59899

courts@ferencelaw.com

Brian Samuel Malkin

Pa. ID No. 70448

bmalkin@ferencelaw.com

FERENCE & ASSOCIATES LLC

409 Broad Street

Pittsburgh, Pennsylvania 15143

(412) 741-8400 - Telephone

(412) 741-9292 - Facsimile

Attorneys for Plaintiff

Schedule “A”
Defendants With Store Name and Seller ID

| Defendant No. | Defendant/Store Name | Seller ID |
|----------------------|-----------------------------|------------------|
| 1 | TeeGem | AN21726EIDXNL |
| 2 | Blessing Baby | A1SWVYLINGUQEX |
| 3 | chaelamody | A1BRDSA9WMLW41 |
| 4 | chubby zebra | A1C69HACEBMTUX |
| 5 | dadius | AZNX1OKW4638X |
| 6 | HeathyBaby | A2NMK0HP9XU5ZJ |
| 7 | Infant Self | A1IH55VFZSTN8P |
| 8 | iyooou | A14GT8T2B409VP |
| 9 | iZZZHH | A2FX6QRN4IAAS9 |
| 10 | KidDazzle | A3B4DSQJEFYQTN |
| 11 | Micolan | A37ZM6B4LEF3AH |
| 12 | PandaEar | A3JCF7FZMSUD5X |
| 13 | SODEE | A14HXWUCQVA1GK |
| 14 | Termichy | A3CU8R5KLM2G5Y |
| 15 | TongXing US | A3OVVGRK7T2C6K |

LISTING OF EXHIBITS

Exhibit 1.....Screenshots from Plaintiff’s Websites and Amazon Stores
Exhibit 2 A.....U.S. Design Patent No. RE48,520
Exhibit 2 B.....U.S. Design Patent No. RE48,743
Exhibit 2 C.....U.S. Design Patent No. RE48,531
Exhibit 2 D.....U.S. Design Patent No. 799,280

EXHIBIT 1



nooli

Home Home Party

Search All Nooli

✓ SHALLOW SPOON
The perfect fit for a baby's line to help them easily slide the spoon with each bite.

✓ CHOKE SHIELD
Safety first for little ones start our choke shield prevents the baby from sticking the spoon into their mouth.

✓ ERGONOMIC HANDLE
Our unique design comfortably matches the development of the younger grasp and improves fine motor skills.



NOOLI Made in The USA First Self Feed Baby Utensils - Anti-Choke, BPA Free Baby Spoon...

★★★★★ 1,477

Over 800,000+ Reviews

ig™ ig™ ig™ ig™

UPPER

Get it by Friday, January 23

Prevent self-feeding. Encourage self-feeding with the star-shaped baby feeding spoon and fork set. Short, ergonomically shaped handles help babies better hold on to a spoon.

Supports fine motor skills. As your toddlers feed themselves, they develop fine and gross motor skills. The short ergonomic handle supports proper pencil grip and hand-eye coordination development.

Dishwasher safe. Your hands are full as is. These dishwasher-safe toddler spoons and forks won't add to your workload. Just make sure you wash them on the top rack.

Made in the USA. Proudly made right here in the USA. This toddler and baby silverware set is free from BPA, lead, phthalates, and more.

See all details Add to Cart

Sold by Etkind and Fulfilled by Amazon





PROMOTE SELF FEEDING
Encourage self-feeding with the star-shaped baby feeding spoon and fork set. Short, ergonomically shaped handles help babies better hold on to a spoon.

SUPPORTS FINE MOTOR SKILLS
As your toddlers feed themselves, they develop fine and gross motor skills. The short ergonomic handle supports proper pencil grip and hand-eye coordination development.

DISHWASHER SAFE
Your hands are full as is. These dishwasher-safe toddler spoons and forks won't add to your workload. Just make sure you wash them on the top rack.

MADE IN THE USA
Proudly made right here in the USA. This toddler and baby silverware set is free from BPA, lead, phthalates, and more.

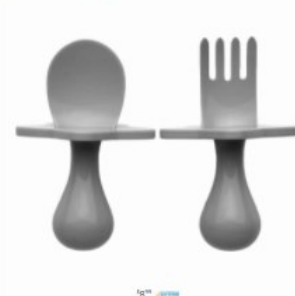
Baby Led Weaning Spoon & Fork



ig™ ig™ ig™ ig™

Share

Share this page with your friends.



<https://noolibaby.com/>



[Shop](#) [Wholesale](#) [Contact Us](#) [🔍](#) [🛒](#)



Be a **Star** with NOOLI Ergonomic Utensils

Made in the U.S.A – these baby utensils promote independent self-feeding and come with a choke protection guard for added safety.

[Shop Now](#)

Best Baby Led Weaning Cutlery for Ages 6 Months+



Toddler Utensils Set - Blue

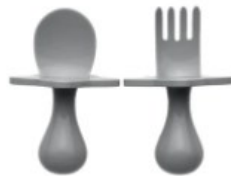

Toddler Utensils Set - Gray



Toddler Utensils Set - Pink

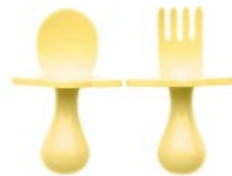

Toddler Utensils Set - Yellow

https://www.amazon.com/stores/Grabease/page/63D823A5-0430-4359-9A94-3E39DAD7FA67?ref=ast_bln



Grabease [Follow](#) [HOME](#) [UTENSILS](#) [TOOTHBRUSH](#) [ALLOWER BIBS](#) [CHOOSE YOUR GRABEASE](#) [ALL PRODUCTS](#) [POSTS](#)

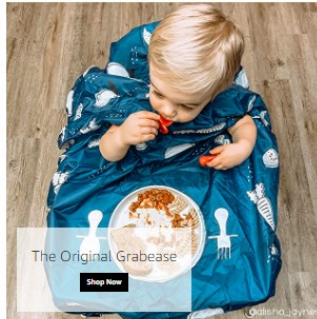

Grabease Utensils Set For Baby Led Weaning

Grabease are designed to give toddlers the opportunity to eat independently

113"



Teething & Self Feeding Made Easy

A painful phase turned into a learning process with our 2-in-1 silicone spoon + teether.

[SHOP NOW](#)

<https://grabease.com/collections/all-products>

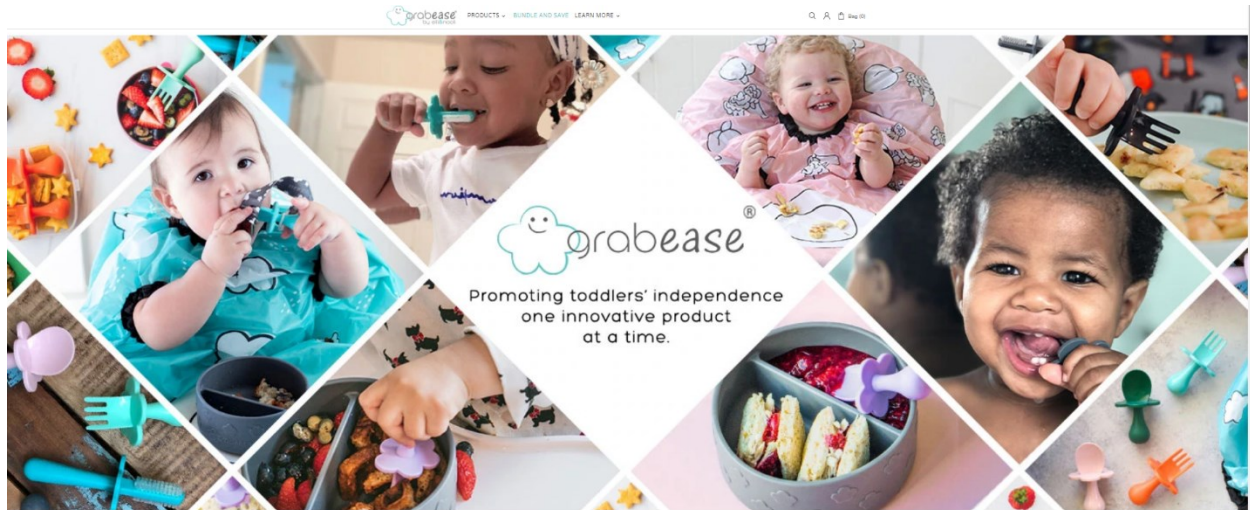

ERGONOMIC UTENSILS

Our safe, non-toxic baby & toddler products are ergonomically designed with children's independence in mind.

SHALLOW SPOON
Allows baby to easily clean spoon with lips

CHOKES PROTECTION BARRIER
Prevents from sticking too far into their mouths and gagging

ERGONOMIC HANDLE
Promotes pincer grasp and improves fine motor skills

RECOMMENDED AGE 6 MONTHS*

PEDIATRICIAN TESTED | PATENTED ORIGINAL | BPA FREE | PVC FREE | PHTHALATES FREE | NO TOXIC CHEMICALS



Dinnerware Set:
Ergonomic Utensils with Travel Case
★★★★★ 3604 reviews
\$14.50

Pay in full or in 4 interest-free installments for orders between \$50 and \$3000 with [shopify](#) [Learn more](#)

Exhibit 2A



US00RE48520E

(19) **United States**
(12) **Reissued Patent**
Shalev

(10) **Patent Number:** **US RE48,520 E**
(45) **Date of Reissued Patent:** **Apr. 20, 2021**

- (54) **TODDLER FORK**
- (71) Applicant: **ELLI & NOOLI, LLC**, Los Angeles, CA (US)
- (72) Inventor: **Maya Shalev**, Los Angeles, CA (US)
- (73) Assignee: **ELLI & NOOLI, LLC**, Los Angeles, CA (US)
- (21) Appl. No.: **29/729,409**
- (22) Filed: **Mar. 26, 2020**

D349,770 S * 8/1994 Jarnagin D24/198
 D413,049 S * 8/1999 Bergkvist D7/653
 D419,397 S * 1/2000 Liu D7/663
 6,134,790 A * 10/2000 Watson A47G 21/02
 30/295

(Continued)

Primary Examiner — Philip S Hyder
(74) *Attorney, Agent, or Firm* — K&L Gates LLP

(57) **CLAIM**

The ornamental design for a toddler fork, as shown and described herein.

Related U.S. Patent Documents

Reissue of:

- (64) Patent No.: **Des. 799,910**
- Issued: **Oct. 17, 2017**
- Appl. No.: **29/558,965**
- Filed: **Mar. 23, 2016**

U.S. Applications:

- (62) Division of application No. 29/704,367, filed on Sep. 4, 2019, which is an application for the reissue of Pat. No. Des. 799,910.
- (51) **LOC (13) Cl.** **07-03**
- (52) **U.S. Cl.** **D7/653**
- (58) **Field of Classification Search**
- USPC D7/402.1, 642–645, 653–664, 691; D8/107, 14; D21/525
- CPC A47G 21/00; A47G 21/004; A47G 21/005; A47G 21/023; A47G 21/04; A47G 21/06; A47G 21/08; A47J 43/28; A47J 43/281; A47J 43/282
- See application file for complete search history.

DESCRIPTION

Notice: More than one reissue application has been filed for the reissue of U.S. Pat. No. D. 799,910. This application is a reissue divisional of U.S. application Ser. No. 29/704,367, which is an application for reissue of U.S. Pat. No. D. 799,910.

FIG. 1 illustrates a side view of a toddler fork showing my new design, the opposite side a mirror image thereof
 FIG. 2 illustrates a top plan view of the toddler fork of FIG. 1.
 FIG. 3 illustrates a bottom plan view of the toddler fork of FIG. 1.
 FIG. 4 illustrates a front elevational view of the toddler fork of FIG. 1.
 FIG. 5 illustrates a perspective view of the top-side of the toddler fork of FIG. 1; and,
 FIG. 6 illustrates a perspective view of the bottom-side of the toddler fork of FIG. 1.
 Any broken lines in the drawings are for illustrative purposes only and form no part of the claimed design. Additionally, the toddler fork is not limited to the scale shown herein.

(56) **References Cited**

U.S. PATENT DOCUMENTS

- D148,693 S * 2/1948 Grosvenor D7/644
- D336,520 S * 6/1993 McDaniel D24/194
- D339,036 S * 9/1993 McDaniel D7/643
- D339,063 S * 9/1993 Simon D9/432

1 Claim, 6 Drawing Sheets

Matter enclosed in heavy brackets [] appears in the original patent but forms no part of this reissue; matter printed in italics indicates the additions made by reissue.

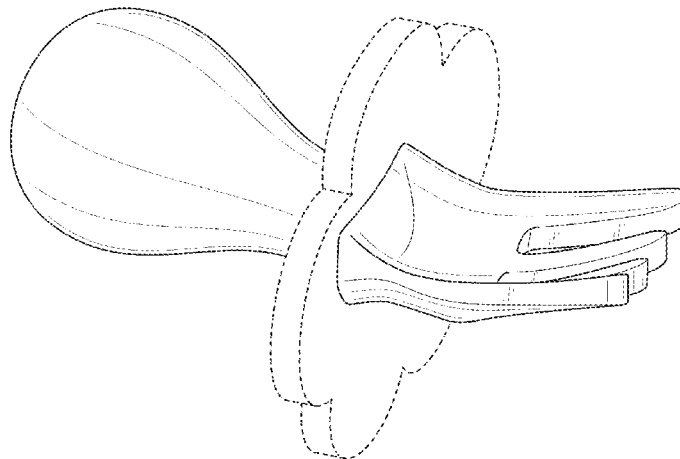

AMENDED

(56)

References Cited

U.S. PATENT DOCUMENTS

| | | | | | | |
|----------|---|---|---------|-------------------|-------|----------|
| D482,248 | S | * | 11/2003 | Roehrig | | D7/663 |
| D491,420 | S | * | 6/2004 | Shibata | | D7/653 |
| D496,833 | S | * | 10/2004 | Lantz | | D7/653 |
| D582,046 | S | * | 12/2008 | Rohrig | | D24/194 |
| D592,019 | S | * | 5/2009 | Holcomb | | D7/643 |
| D615,367 | S | * | 5/2010 | Sierra | | D7/653 |
| D621,229 | S | * | 8/2010 | De Bretton Gordon | | D7/645 |
| D657,621 | S | * | 4/2012 | Pookrum | | D7/401.2 |
| D682,613 | S | * | 5/2013 | De Leo | | D7/401.2 |
| D695,361 | S | * | 12/2013 | Roehrig | | D21/525 |
| D707,307 | S | * | 6/2014 | Roehrig | | D21/525 |
| D789,160 | S | * | 6/2017 | Strandberg | | D7/643 |
| D834,381 | S | * | 11/2018 | Appelbaum | | D7/653 |
| D834,382 | S | * | 11/2018 | Appelbaum | | D7/653 |
| D850,197 | S | * | 6/2019 | Thrailkill | | D7/401.2 |

* cited by examiner

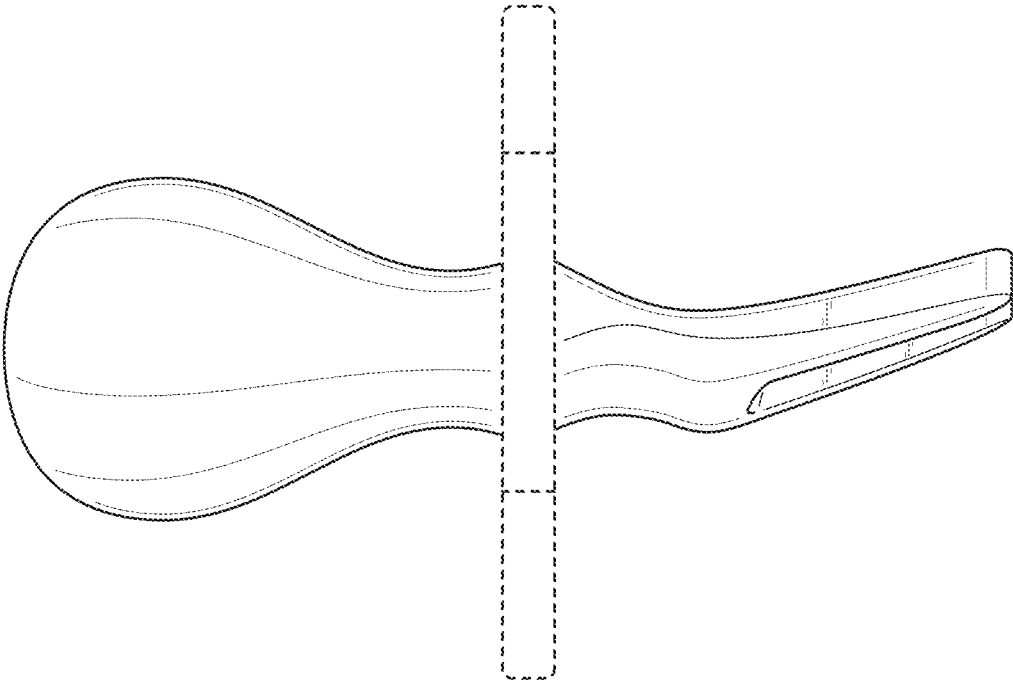

FIG. 1 AMENDED

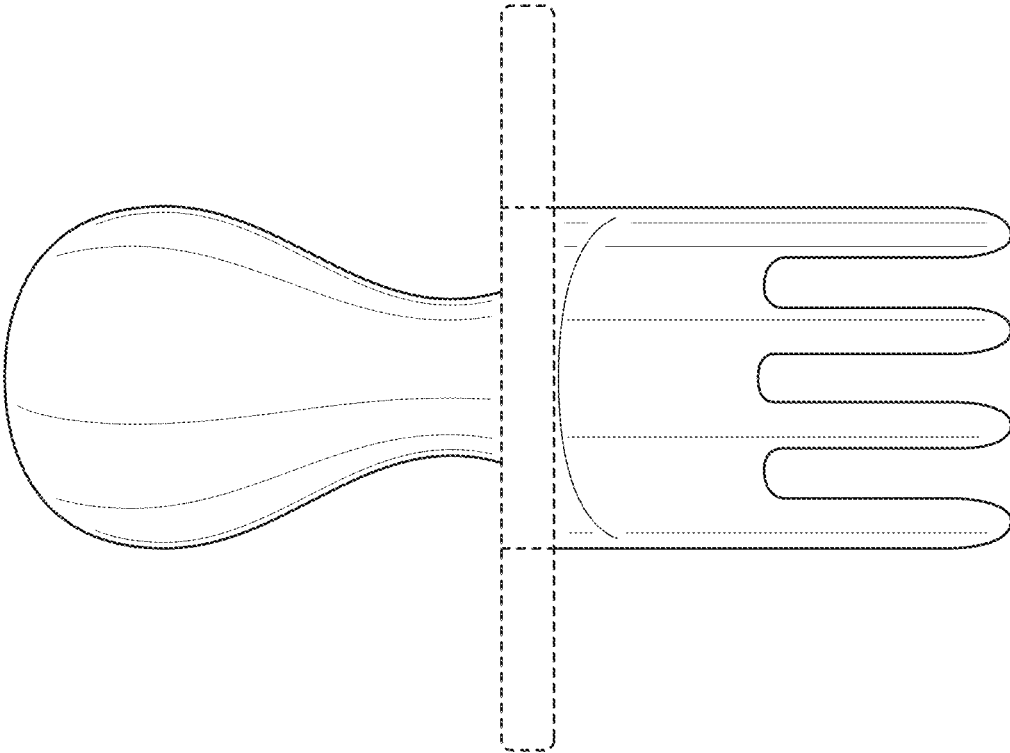

FIG. 2 AMENDED

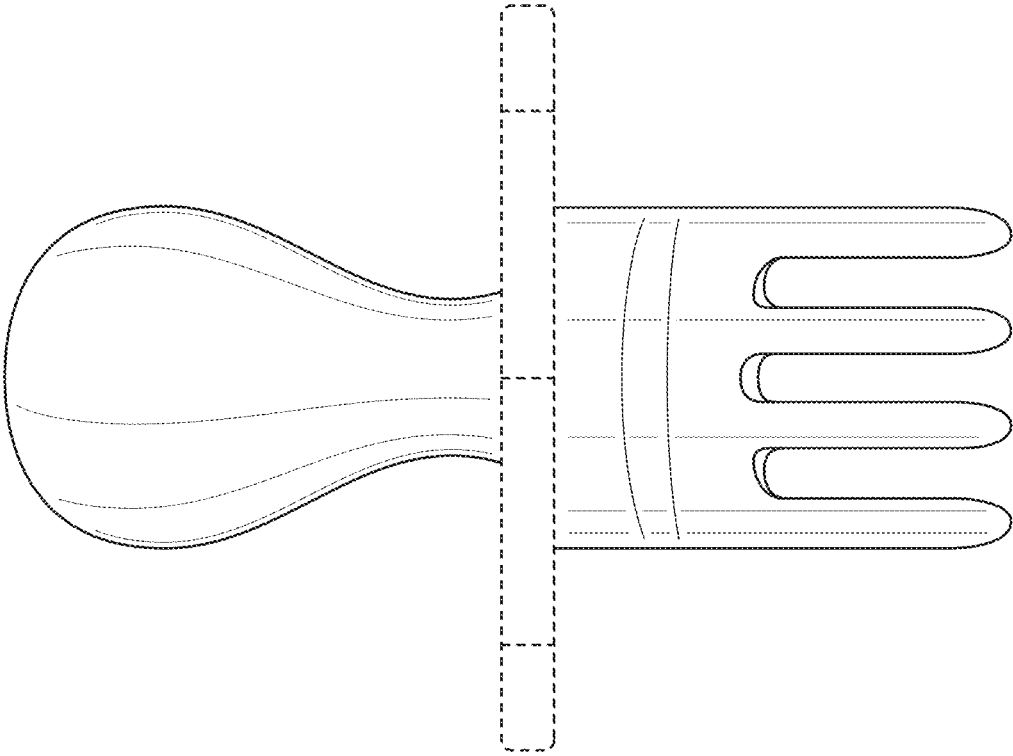

FIG. 3 AMENDED

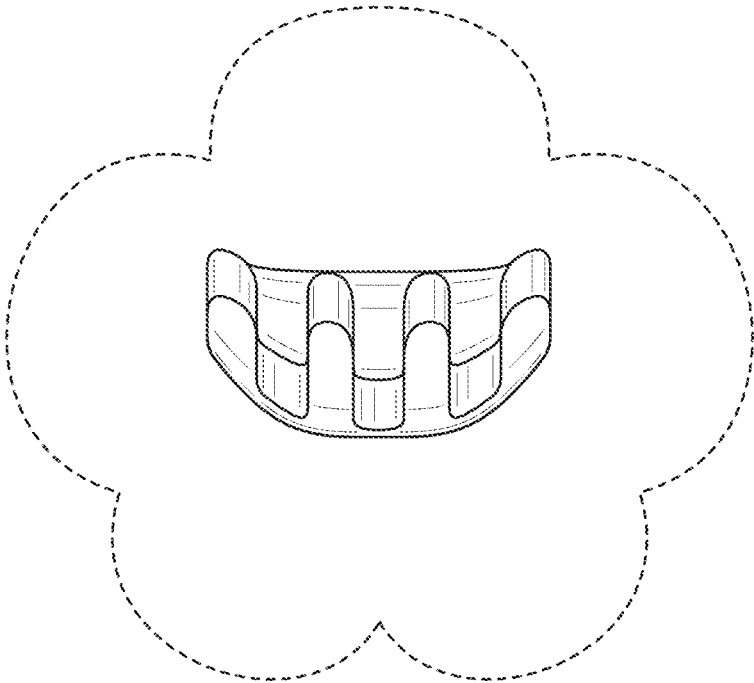

FIG. 4 AMENDED

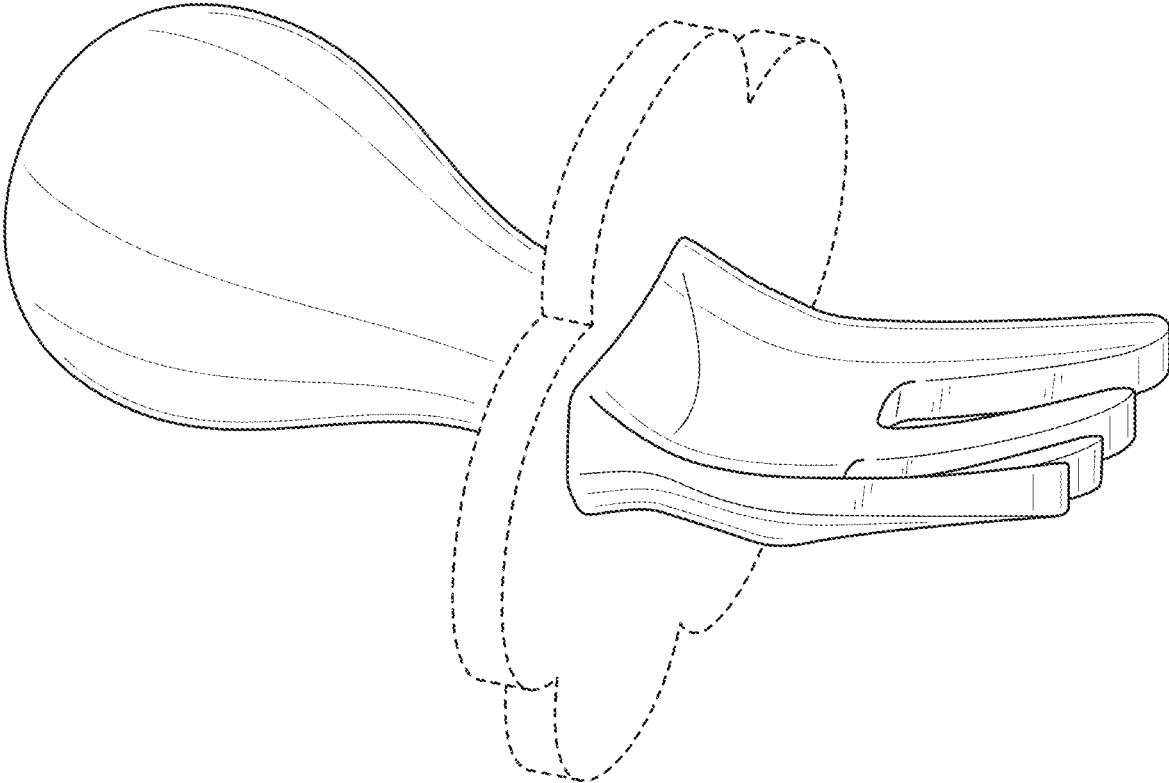

FIG. 5 AMENDED

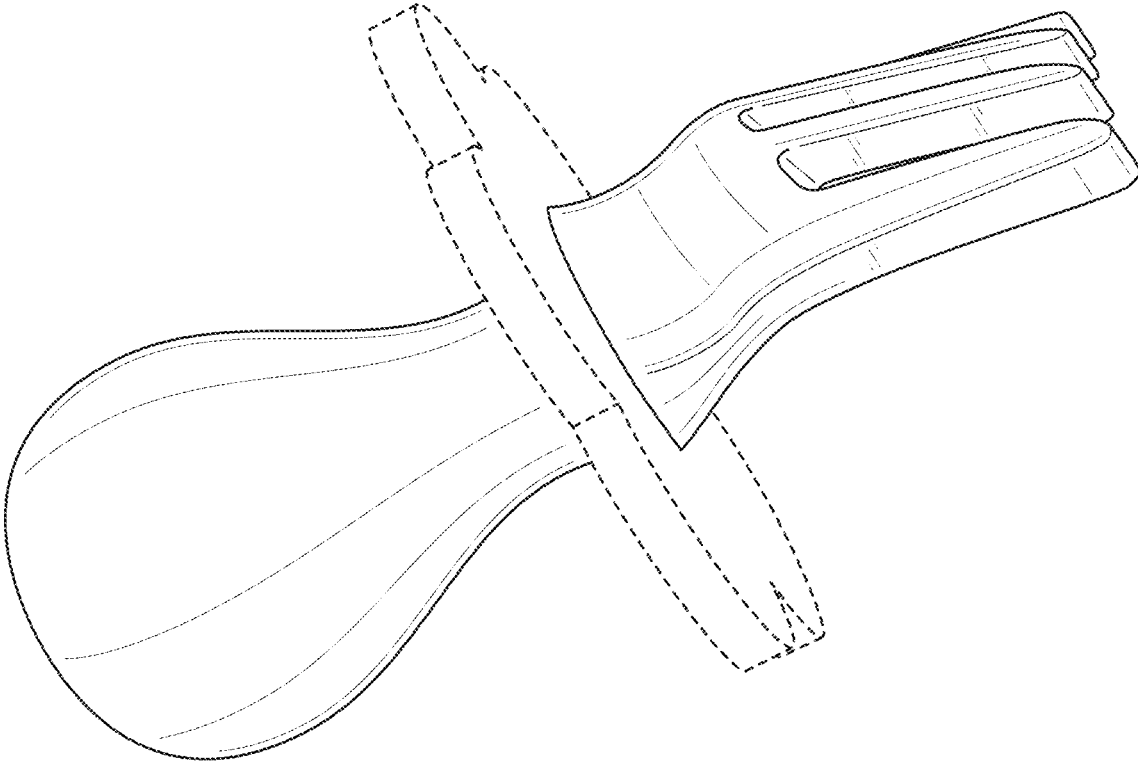

FIG. 6 AMENDED

Exhibit 2B



US00RE48743E

(19) **United States**
(12) **Reissued Patent**
Shalev

(10) **Patent Number:** **US RE48,743 E**
(45) **Date of Reissued Patent:** **Sep. 21, 2021**

- (54) **TODDLER FORK**
- (71) Applicant: **ELLI & NOOLI, LLC**, Los Angeles, CA (US)
- (72) Inventor: **Maya Shalev**, Los Angeles, CA (US)
- (73) Assignee: **Elli & Nooli, LLC**, Los Angeles, CA (US)
- (21) Appl. No.: **29/704,367**
- (22) Filed: **Sep. 4, 2019**

Related U.S. Patent Documents

Reissue of:

- (64) Patent No.: **Des. 799,910**
- Issued: **Oct. 17, 2017**
- Appl. No.: **29/558,965**
- Filed: **Mar. 23, 2016**

- (51) **LOC (13) Cl.** **07-03**
- (52) **U.S. Cl.**
- USPC **D7/653**
- (58) **Field of Classification Search**
- USPC D7/368, 401.2, 642-645, 653-664, 669, D7/675-677, 683, 688-689, 691; D8/107, 300-301; D21/576, 606-609, D21/625-627; D22/117-118; D24/194, D24/196
- CPC ... A01D 9/02; A01D 9/04; A01D 9/06; A47G 21/00; A47G 21/004; A47G 21/005; A47G 21/02; A47G 21/023; A47G 21/04; A47G 21/06; A47G 21/08; A47J 43/28; A47J 43/281; A47J 43/282; A61F 13/10; A61J 7/0023; A46B 5/02; B25G 1/00; B25G 1/01; B25G 1/02; B25G 3/00; B65D 75/56; B65D 75/563; B65D 75/566; B67B 7/00; B67B 7/724; B67B 7/73

See application file for complete search history.

(56) **References Cited**

U.S. PATENT DOCUMENTS

| | | | | |
|--------------|--------|-----------|-------|---------|
| D148,693 S * | 2/1948 | Grosvenor | | D21/406 |
| D336,520 S * | 6/1993 | McDaniel | | D24/194 |
| D339,036 S * | 9/1993 | McDaniel | | D7/643 |
| D349,770 S * | 8/1994 | Jarnagin | | D24/198 |

(Continued)

Primary Examiner — Philip S Hyder

(74) *Attorney, Agent, or Firm* — K&L Gates LLP

(57) **CLAIM**

The ornamental design for a toddler fork, as shown and described herein.

DESCRIPTION

More than one reissue application has been filed for the reissue of U.S. Pat. No. D. 799,910. U.S. application Ser. No. 29/729,403, filed Mar. 26, 2020 and U.S. application Ser. No. 29/729,409, filed Mar. 26, 2020 were filed as divisional reissue applications from reissue U.S. application Ser. No. 29/704,367.

FIG. 1 illustrates a side view of a toddler fork showing my new design, the opposite side view being a mirror image thereof.

FIG. 2 illustrates a top plan view of the toddler fork of FIG. 1.

FIG. 3 illustrates a bottom plan view of the toddler fork of FIG. 1.

FIG. 4 illustrates a front elevational view of the toddler fork of FIG. 1.

FIG. 5 illustrates a perspective view of the top-side of the toddler fork of FIG. 1; and,

FIG. 6 illustrates a perspective view of the bottom-side of the toddler fork of FIG. 1.

Any broken lines in the drawings are for illustrative purposes only and form no part of the claimed design. Additionally, the toddler fork is not limited to the scale shown herein.

1 Claim, 6 Drawing Sheets

Matter enclosed in heavy brackets [] appears in the original patent but forms no part of this reissue; matter printed in italics indicates the additions made by reissue.

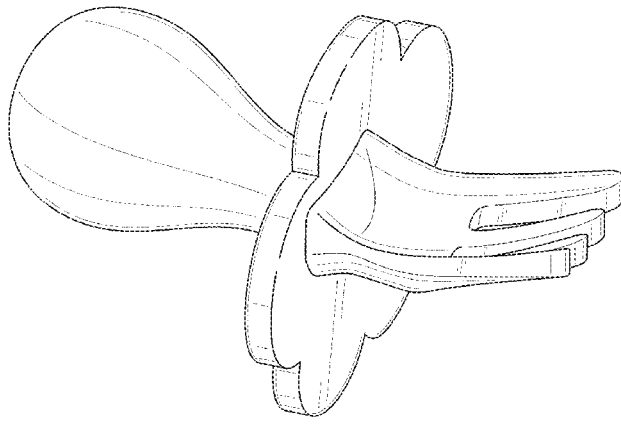

AMENDED

(56)

References Cited

U.S. PATENT DOCUMENTS

5,890,223 A * 4/1999 Klemmer A47G 21/02
30/150
D413,049 S * 8/1999 Bergkvist D7/653
6,134,790 A * 10/2000 Watson A47G 21/02
30/295
D482,248 S * 11/2003 Roehrig D7/663
6,668,415 B2 * 12/2003 Rohrig A46B 5/02
15/167.1
D491,420 S * 6/2004 Shibata D7/653
D496,833 S * 10/2004 Lantz D7/653
D567,383 S * 4/2008 Rohrig D24/194
D582,046 S * 12/2008 Rohrig D24/194
D592,019 S * 5/2009 Holcomb D7/643
D616,557 S * 5/2010 Roehrig D24/194
D619,414 S * 7/2010 Williams D7/401.2
D641,595 S * 7/2011 Matari D7/642
D655,138 S * 3/2012 Roberts D7/401.2
D676,718 S * 2/2013 Rockwell D7/642
D682,613 S * 5/2013 De Leo D7/401.2
D695,361 S * 12/2013 Roehrig D21/525
D707,307 S * 6/2014 Roehrig D21/525
D790,929 S * 7/2017 Perez D7/401.2
D797,525 S * 9/2017 Garza, Jr. D7/653
D799,280 S * 10/2017 Shalev D7/653
D799,910 S * 10/2017 Shalev D7/653

* cited by examiner

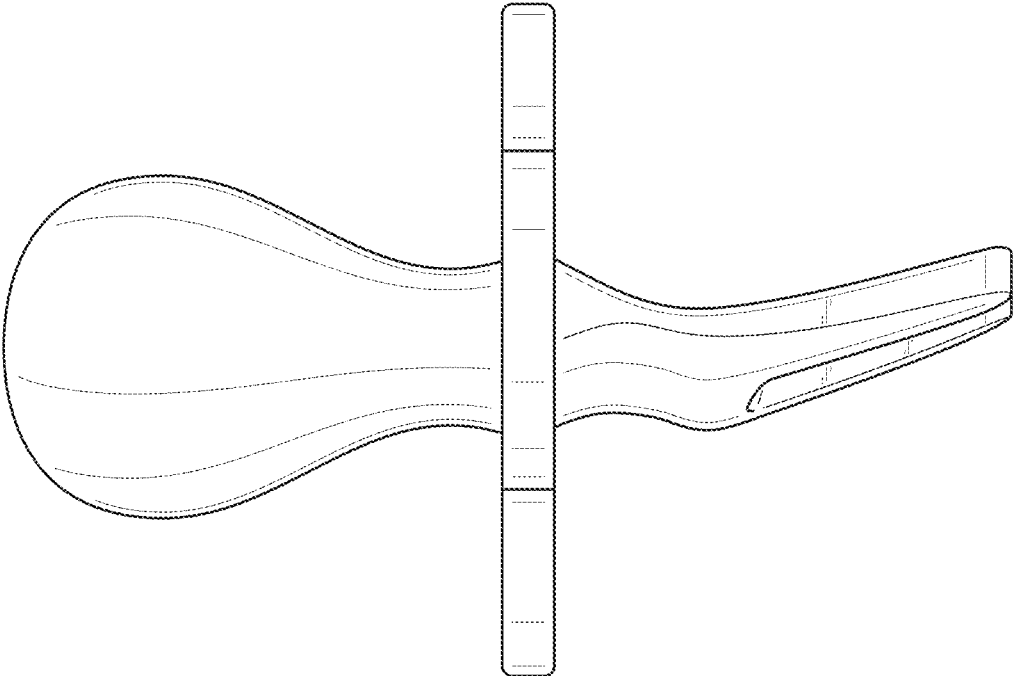

FIG. 1

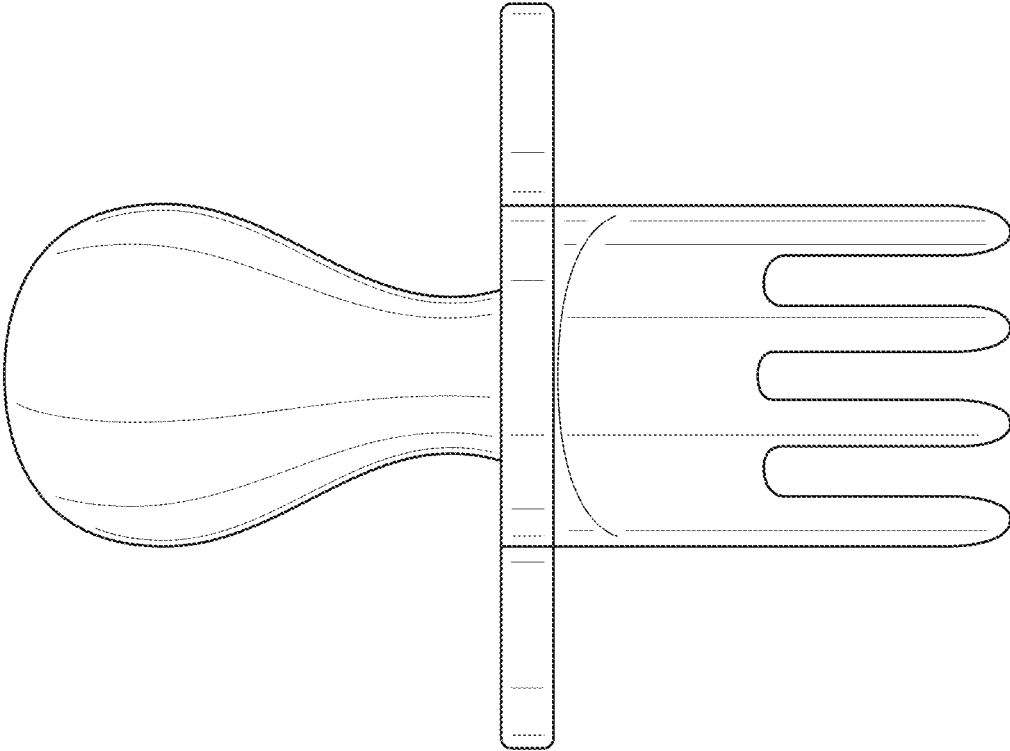

FIG. 2

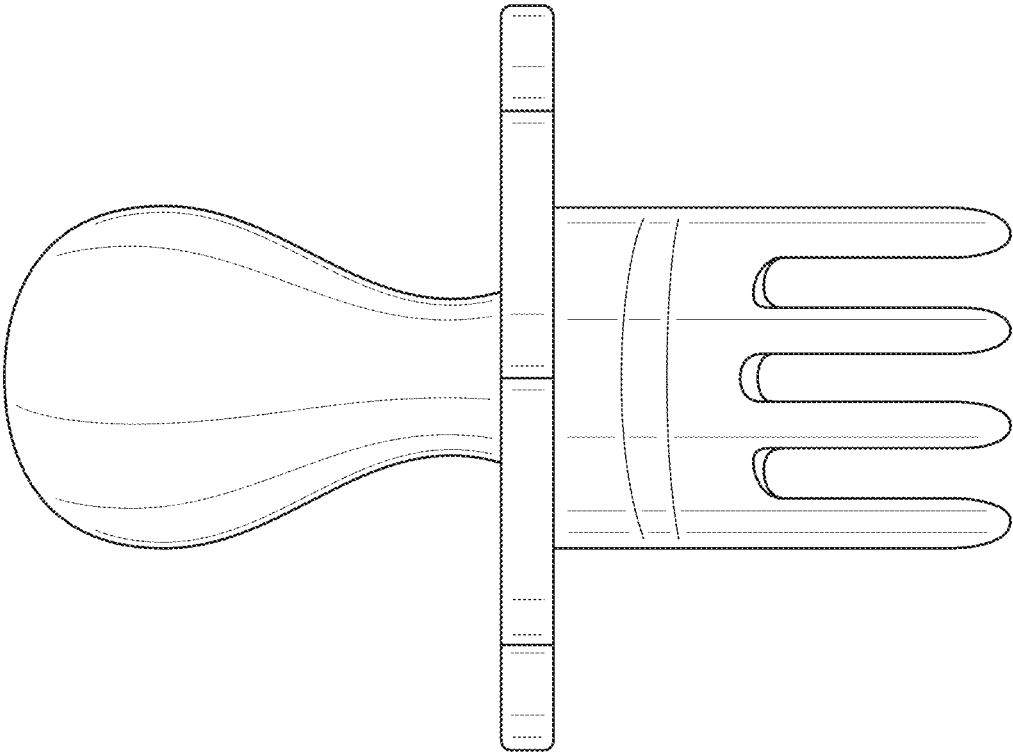

FIG. 3

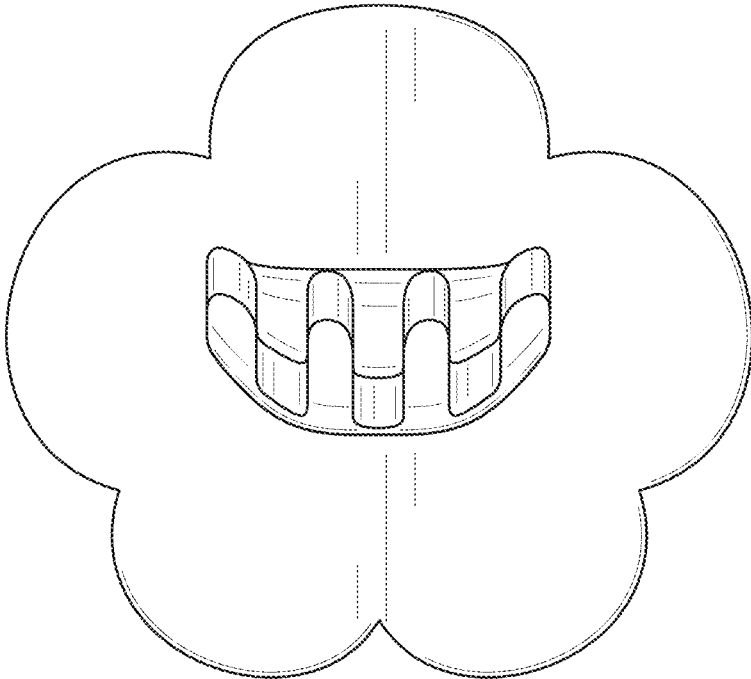

FIG. 4 AMENDED

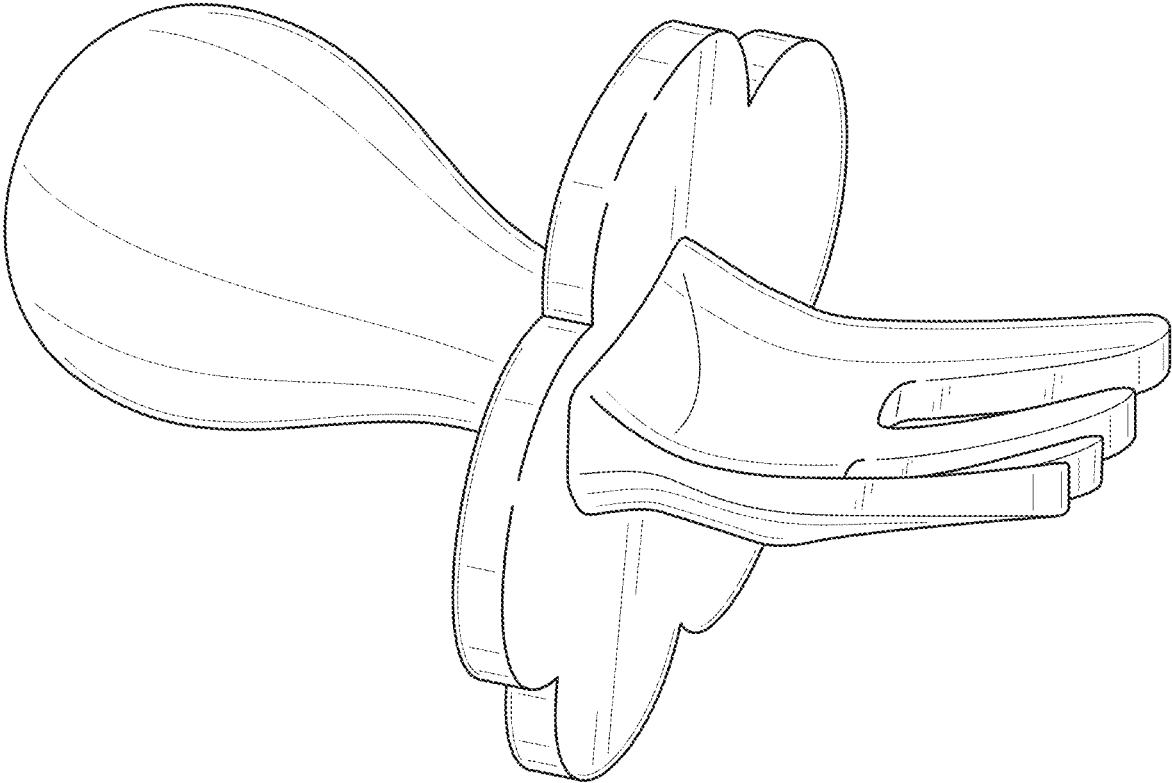

FIG. 5 AMENDED

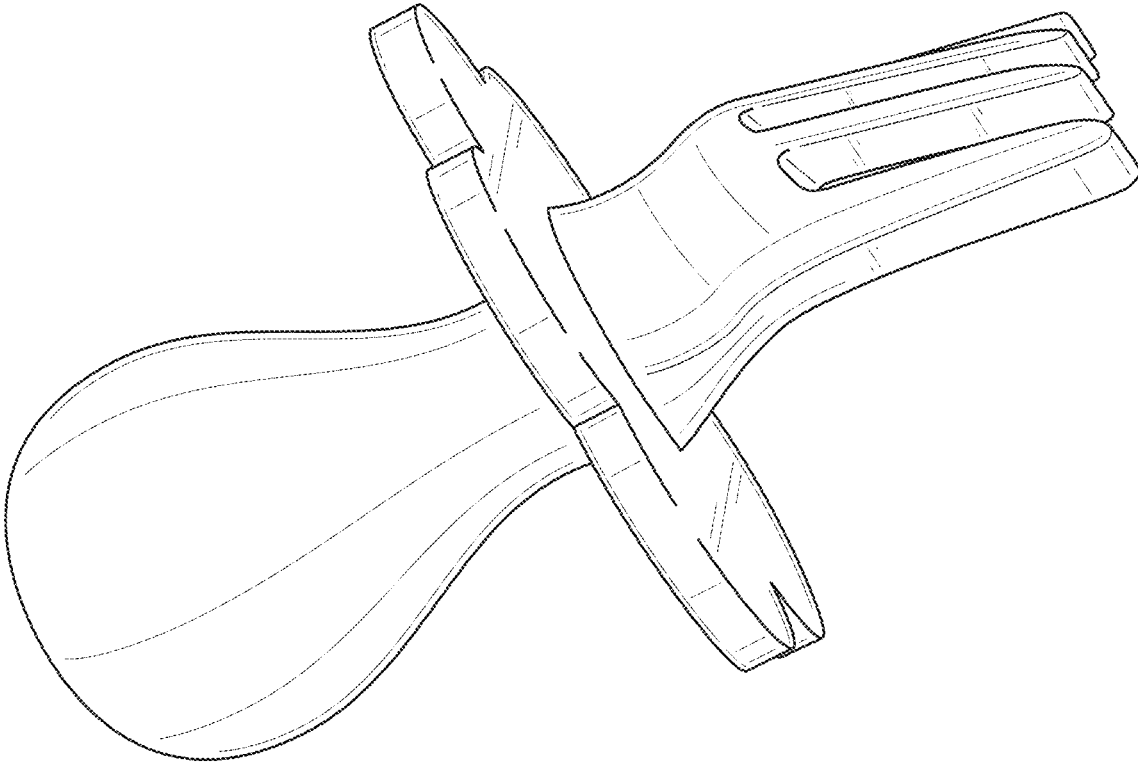

FIG. 6 AMENDED

Exhibit 2C



US00RE48531E

(19) **United States**
(12) **Reissued Patent**
Shalev

(10) **Patent Number:** **US RE48,531 E**
(45) **Date of Reissued Patent:** **Apr. 27, 2021**

- (54) **TODDLER SPOON**
- (71) Applicant: **ELLI & NOOLI, LLC**, Los Angeles, CA (US)
- (72) Inventor: **Maya Shalev**, Los Angeles, CA (US)
- (73) Assignee: **ELLI & NOOLI, LLC**, Los Angeles, CA (US)
- (21) Appl. No.: **29/733,763**
- (22) Filed: **May 6, 2020**

| | | | | | |
|----------|-----|--------|-----------|-------|---------|
| D339,063 | S * | 9/1993 | Simon | | D9/432 |
| D349,770 | S * | 8/1994 | Jarnagin | | D24/198 |
| D413,049 | S * | 8/1999 | Bergkvist | | D7/653 |
| D419,397 | S * | 1/2000 | Liu | | D7/663 |

(Continued)

Primary Examiner — Philip S Hyder
(74) *Attorney, Agent, or Firm* — K&L Gates LLP

(57) **CLAIM**

The ornamental design for a toddler spoon, as shown and described herein.

DESCRIPTION

Notice: More than one reissue application has been filed for the reissue of U.S. Pat. No. D. 799,280. This application is a reissue divisional of U.S. application Ser. No. 29/703,974, which is an application for reissue of U.S. Pat. No. D. 799,280.

FIG. 1 illustrates a side view of a toddler spoon showing my new design, the opposite side view being a mirror image thereof.

FIG. 2 illustrates a top plan view of the toddler spoon of FIG. 1.

FIG. 3 illustrates a bottom plan view of the toddler spoon of FIG. 1.

FIG. 4 illustrates a front elevational view of the toddler spoon of FIG. 1.

FIG. 5 illustrates a perspective view of the top-side of the toddler spoon of FIG. 1; and,

FIG. 6 illustrates a perspective view of the bottom-side of the toddler spoon of FIG. 1.

Any broken lines in the drawings are for illustrative purposes only and form no part of the claimed design. Additionally, the toddler spoon is not limited to the scale shown herein.

1 Claim, 6 Drawing Sheets

Related U.S. Patent Documents

Reissue of:

- (64) Patent No.: **Des. 799,280**
- Issued: **Oct. 10, 2017**
- Appl. No.: **29/558,958**
- Filed: **Mar. 23, 2016**

U.S. Applications:

- (62) Division of application No. 29/703,974, filed on Aug. 30, 2019, which is an application for the reissue of Pat. No. Des. 799,280.
- (51) **LOC (13) Cl.** **07-03**
- (52) **U.S. Cl.**
USPC **D7/653**
- (58) **Field of Classification Search**
USPC D7/402.1, 642-645, 653-664, 691;
D8/107, 14; D21/525
CPC A47G 21/00; A47G 21/004; A47G 21/005;
A47G 21/023; A47G 21/04; A47G 21/06;
A47G 21/08; A47J 43/28; A47J 43/281;
A47J 43/282
See application file for complete search history.

(56) **References Cited**

U.S. PATENT DOCUMENTS

| | | | | | |
|----------|-----|--------|-----------|-------|---------|
| D148,693 | S * | 2/1948 | Grosvenor | | D7/644 |
| D336,520 | S * | 6/1993 | McDaniel | | D24/194 |
| D339,036 | S * | 9/1993 | McDaniel | | D7/643 |

Matter enclosed in heavy brackets [] appears in the original patent but forms no part of this reissue; matter printed in italics indicates the additions made by reissue.

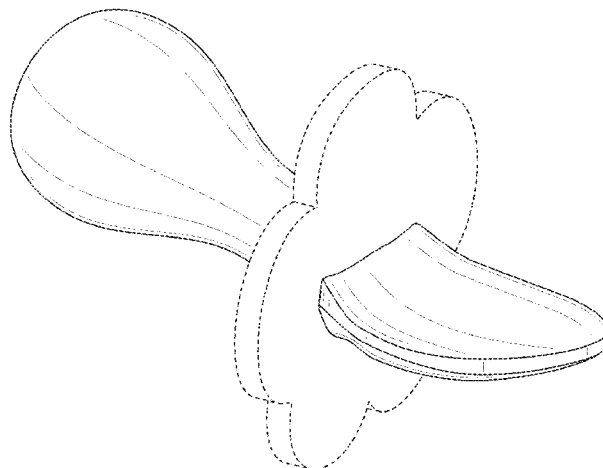

AMENDED

(56)

References Cited

U.S. PATENT DOCUMENTS

| | | | | | | |
|-----------|---|---|---------|-------------------|-------|----------------------|
| 6,134,790 | A | * | 10/2000 | Watson | | A47G 21/02 30/295 |
| D482,248 | S | * | 11/2003 | Roehrig | | D7/663 |
| D491,420 | S | * | 6/2004 | Shibata | | D7/653 |
| D496,833 | S | * | 10/2004 | Lantz | | D7/653 |
| D582,046 | S | * | 12/2008 | Rohrig | | D24/194 |
| D592,019 | S | * | 5/2009 | Holcomb | | D7/643 |
| D615,367 | S | * | 5/2010 | Sierra | | D7/653 |
| D621,229 | S | * | 8/2010 | De Bretton Gordon | | D7/645 |
| D657,621 | S | * | 4/2012 | Pookrum | | D7/401.2 |
| D682,613 | S | * | 5/2013 | De Leo | | D7/401.2 |
| D695,361 | S | * | 12/2013 | Roehrig | | D21/525 |
| D707,307 | S | * | 6/2014 | Roehrig | | D21/525 |
| D789,160 | S | * | 6/2017 | Strandberg | | D7/643 |
| D834,381 | S | * | 11/2018 | Appelbaum | | D7/653 |
| D834,382 | S | * | 11/2018 | Appelbaum | | D7/653 |
| D850,197 | S | * | 6/2019 | Thraillkill | | D7/401.2 |

* cited by examiner

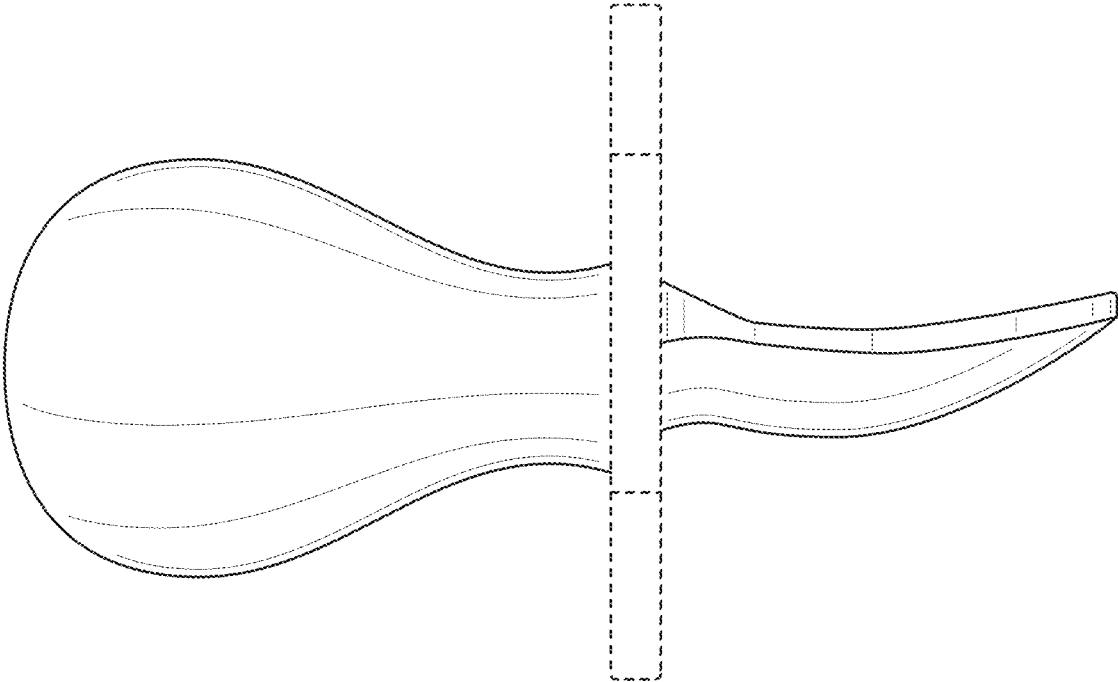

FIG. 1 AMENDED

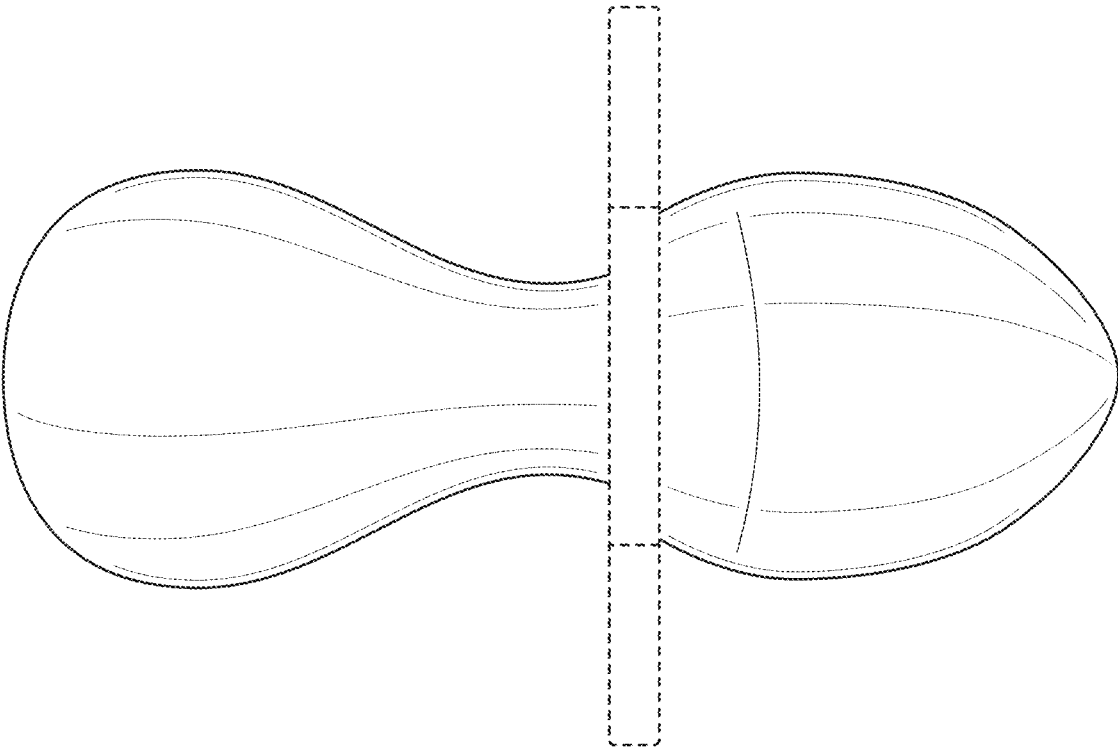

FIG. 2 AMENDED

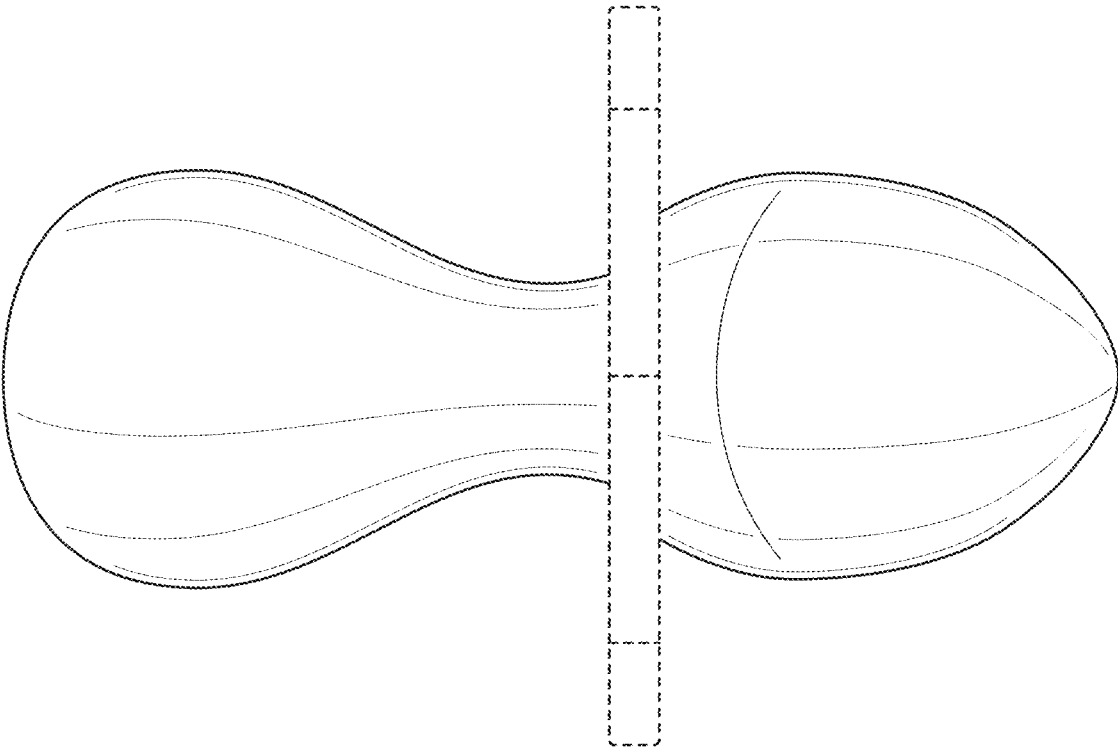

FIG. 3 AMENDED

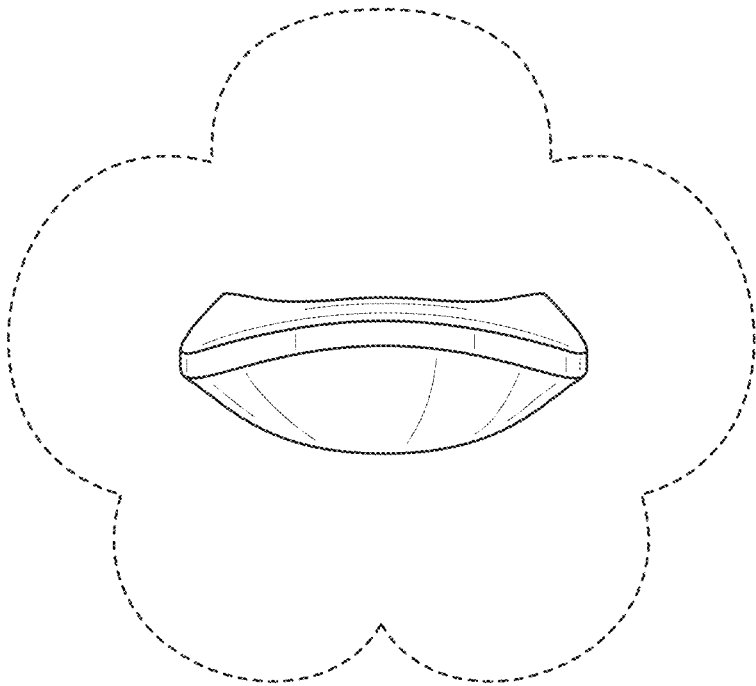

FIG. 4 AMENDED

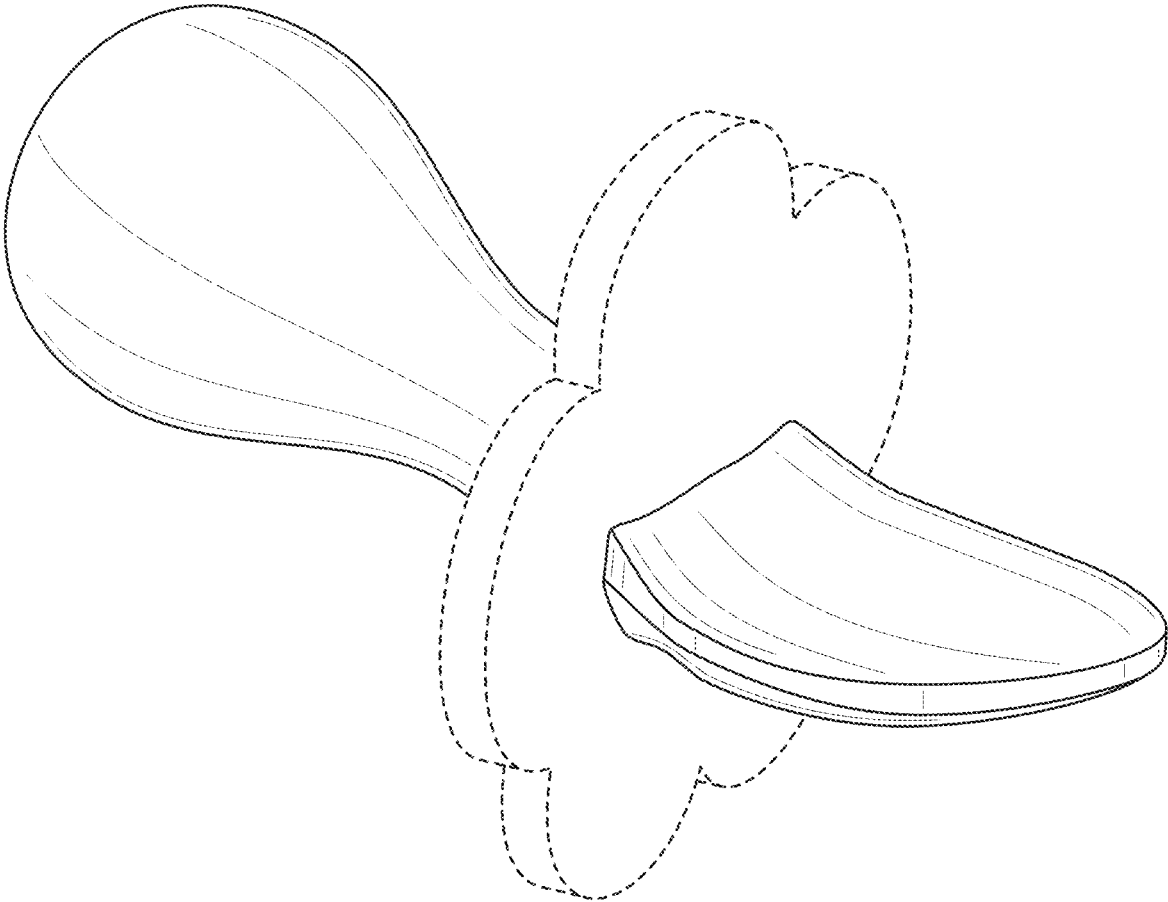

FIG. 5 AMENDED

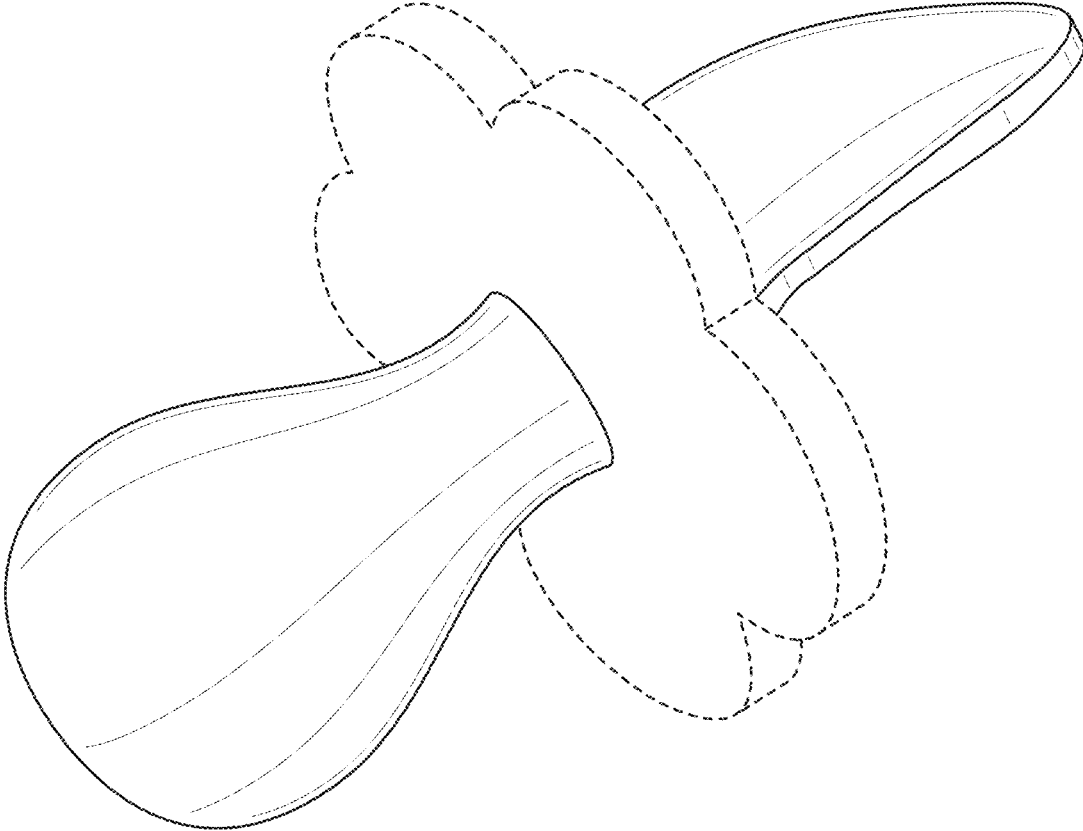

FIG. 6 AMENDED

Exhibit 2D



US00D799280S

(12) **United States Design Patent**
Shalev

(10) **Patent No.:** **US D799,280 S**

(45) **Date of Patent:** **** Oct. 10, 2017**

- (54) **TODDLER SPOON**
- (71) Applicant: **Maya Shalev**, Los Angeles, CA (US)
- (72) Inventor: **Maya Shalev**, Los Angeles, CA (US)
- (73) Assignee: **ELLI & NOOLI, LLC**, Los Angeles, CA (US)
- (**) Term: **15 Years**

| | | | | | | |
|-----------|---|---|---------|-----------|-------|----------------------|
| D349,770 | S | * | 8/1994 | Jarnagin | | D24/198 |
| D413,049 | S | * | 8/1999 | Bergkvist | | D7/653 |
| 6,134,790 | A | * | 10/2000 | Watson | | A47G 21/02 30/295 |
| D482,248 | S | * | 11/2003 | Roehrig | | D7/663 |
| D491,420 | S | * | 6/2004 | Shibata | | D7/653 |
| D496,833 | S | * | 10/2004 | Lantz | | D7/653 |
| D582,046 | S | * | 12/2008 | Rohrig | | D24/194 |
| D592,019 | S | * | 5/2009 | Holcomb | | D7/643 |
| D695,361 | S | * | 12/2013 | Roehrig | | D21/525 |
| D707,307 | S | * | 6/2014 | Roehrig | | D21/525 |

* cited by examiner

Primary Examiner — Ricky Pham

(74) *Attorney, Agent, or Firm* — K&L Gates LLP

- (21) Appl. No.: **29/558,958**
- (22) Filed: **Mar. 23, 2016**
- (51) **LOC (10) Cl.** **07-03**
- (52) **U.S. Cl.**
USPC **D7/653**
- (58) **Field of Classification Search**
USPC D7/368, 401.2, 642–645, 653–664, 669,
D7/675–677, 683, 688–689, 691;
D8/107, 300–301; D21/525, 576,
D21/606–609, 625–627; D22/117–118;
D24/194, 198
CPC ... A01D 9/02; A01D 9/04; A01D 9/06; A47G
21/00; A47G 21/004; A47G 21/005;
A47G 21/02; A47G 21/023; A47G 21/04;
A47G 21/06; A47G 21/08; A47J 43/28;
A47J 43/281; A47J 43/282; A61F 13/10;
A61J 7/0023; B25G 1/00; B25G 1/01;
B25G 1/02; B25G 3/00; B65D 75/56;
B65D 75/563; B65D 75/566; B67B 7/00;
B67B 7/724; B67B 7/73
See application file for complete search history.

(57) **CLAIM**

The ornamental design for a toddler spoon, as shown and described herein.

DESCRIPTION

FIG. 1 illustrates a side view of a toddler spoon showing my new design, the opposite side view being a mirror image thereof.

FIG. 2 illustrates a top plan view of the toddler spoon of FIG. 1.

FIG. 3 illustrates a bottom plan view of the toddler spoon of FIG. 1.

FIG. 4 illustrates a front elevational view of the toddler spoon of FIG. 1.

FIG. 5 illustrates a perspective view of the top-side of the toddler spoon of FIG. 1; and,

FIG. 6 illustrates a perspective view of the bottom-side of the toddler spoon of FIG. 1.

Any broken lines in the drawings are for illustrative purposes only and form no part of the claimed design. Additionally, the toddler spoon is not limited to the scale shown herein.

1 Claim, 6 Drawing Sheets

(56) **References Cited**

U.S. PATENT DOCUMENTS

| | | | | | | |
|----------|---|---|--------|-----------|-------|---------|
| D148,693 | S | * | 2/1948 | Grosvenor | | D21/406 |
| D336,520 | S | * | 6/1993 | McDaniel | | D24/194 |
| D339,036 | S | * | 9/1993 | McDaniel | | D7/643 |

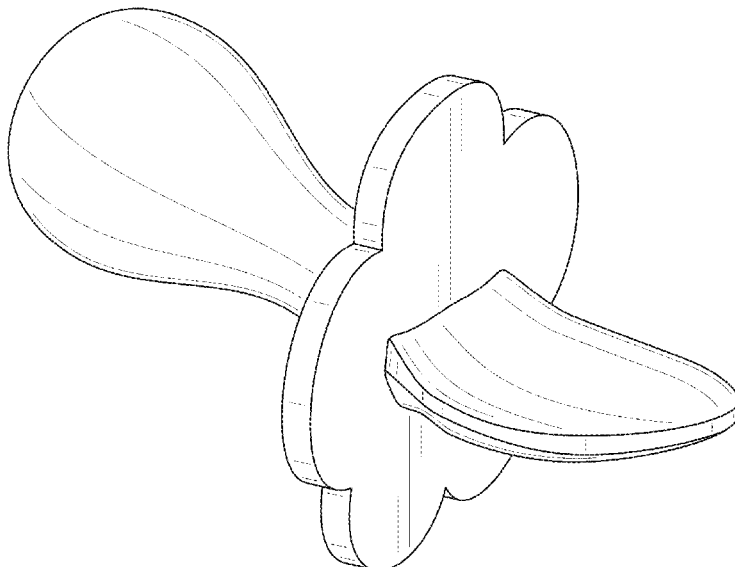

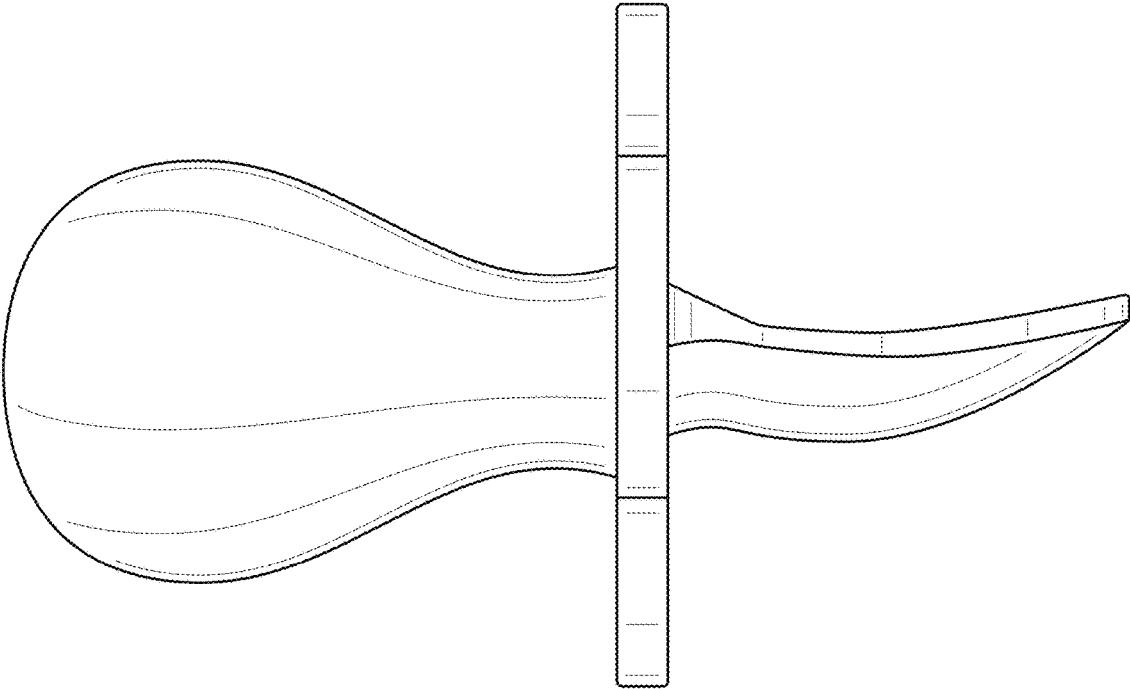

FIG. 1

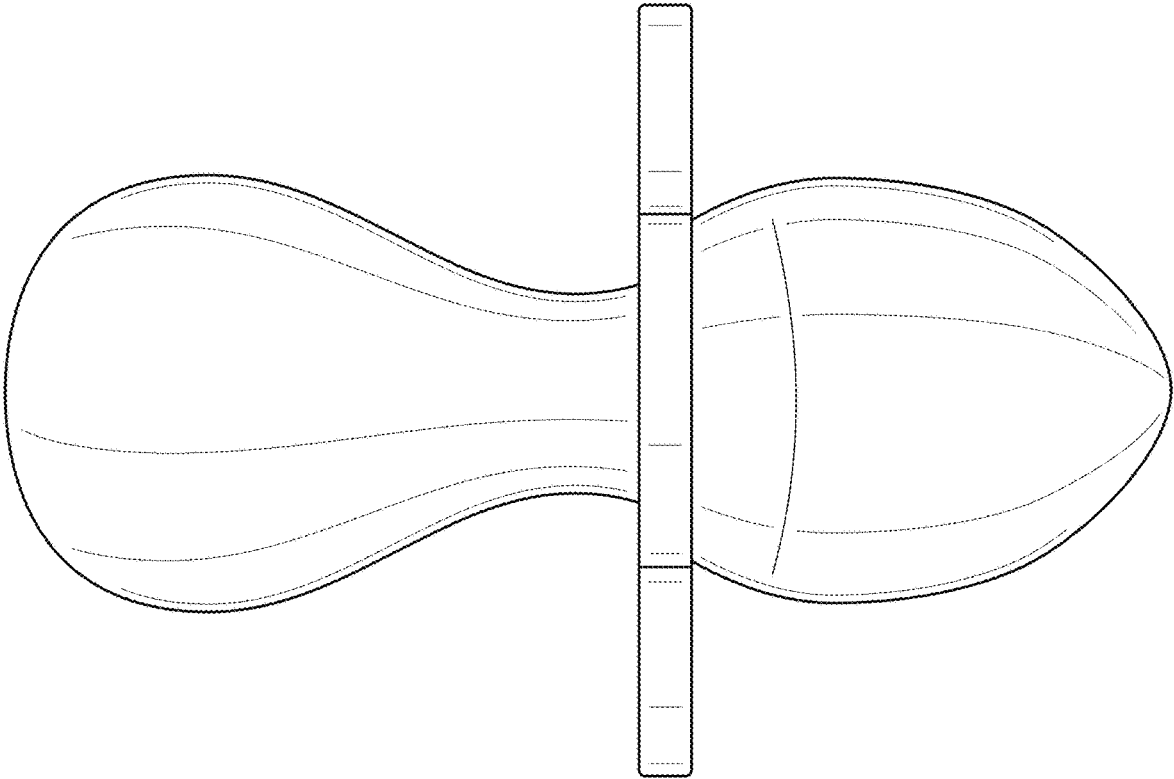

FIG. 2

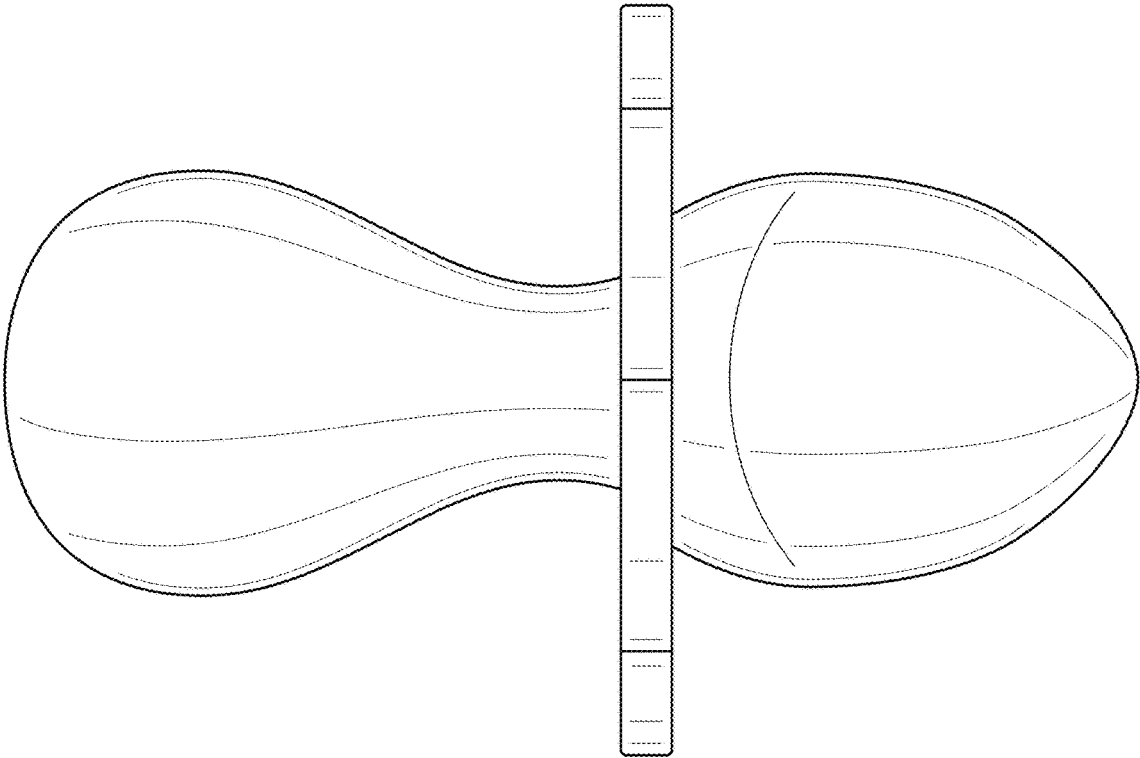

FIG. 3

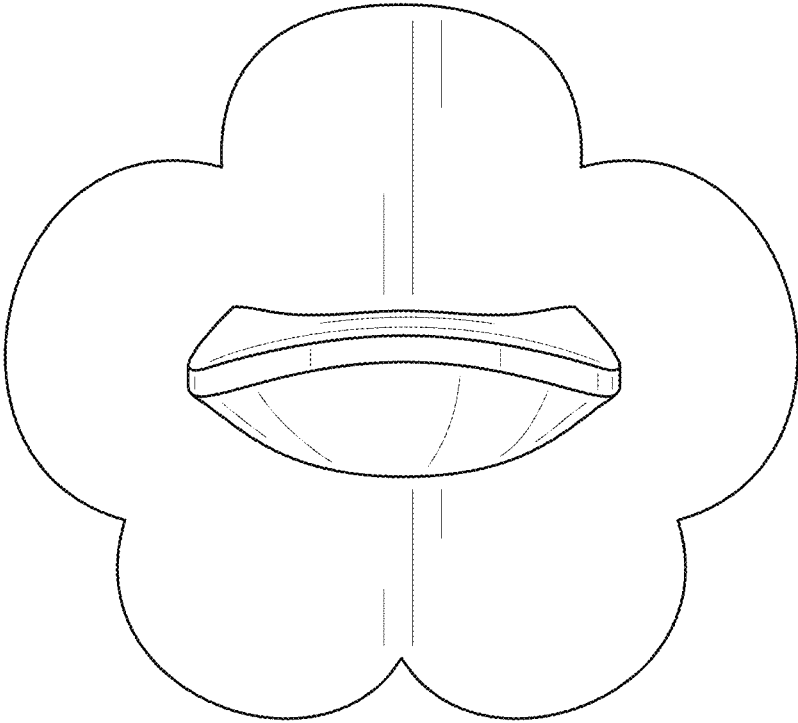

FIG. 4

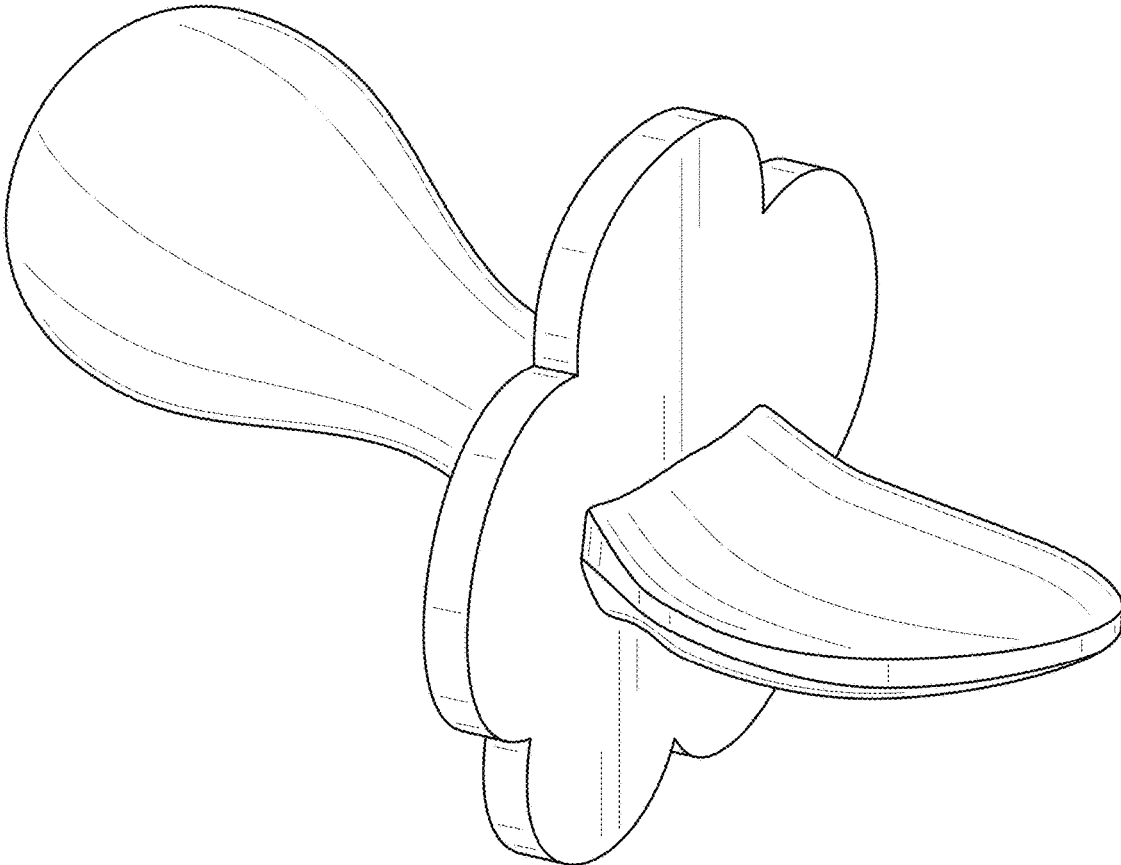

FIG. 5

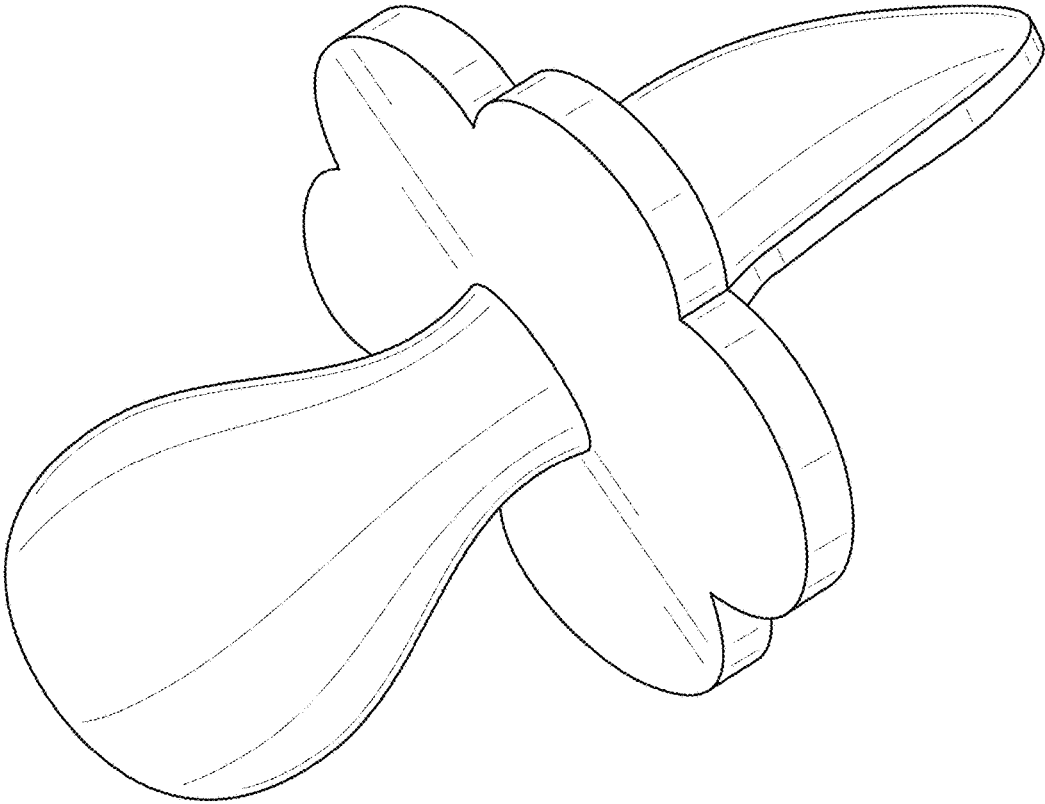

FIG. 6