

IN THE UNITED STATES DISTRICT COURT  
FOR THE WESTERN DISTRICT OF PENNSYLVANIA

BROADWAY PINE BRANDS LLC,  
Plaintiff,

v.

OATSLIKEME, BABYS WE, BESSLE, BEST GOODS FOR HOME, BUBERCUTE, CASTLE SKY, CHILDHOOD, DOOMEDHAPPY, EFFSTOR, ETERNITY SHOP, HOME HAVE FUN, HOOM JOURNAL, HS FASHION, JIAQI HOME DECORATION, JJY HOME, JOY AND PEACE, LIE FLAT, OVERFLIGHT, PANDA PET SUPPLIES, PERFECT BOUTIQUE GIFT, SS BAG, TAOLE HOUSEHOLD DAILY, XINYI HOME LIFE, YUZE COMMERCE, Z L M, AP WARMMER HOUSEHOLD, BAKINGCHEF STORE, BLITE OFFICIAL STORE, CACILLO 01 STORE, CACILLO FLAGSHIP STORE, GLUTINOUS LIFE STORE, HOLIDAY STORE, HOME HAVE FUN STORE, HOMELIFE STORE, KINGBOMBS STORE, KIRIN HOUSEHOLD PRODUCTS STORE, LIFE KITCHEN HOME STORE, LOVELY HOME FURNISHING, LUCKIMA HOME-STORAGE, MCPHEE STORE, MIMIGO STORE, MJ SMILE LIFE STORE, MYOBO STORAGE STORE, RUICHENG OFFICIAL STORE, SHOP1102311339 STORE, SHOP1102627453 STORE, SHOP1102637489 STORE, SHOP1102693333 STORE, SHOP1102800715 STORE, SHOP1102994646 STORE, SHUYA STORE, SPACE MANAGEMENT STORE, STAR MOON STORE, STARFISH BABY STORE, SUPER-RICH HOMESUPPLY STORE, XIUXIN STORE, Y SPACE STORE, YALOO CHARMS STORE, YHSMTG TWO STORE, YJY HOME COLLECTION STORE, ZYJJ STORE, 5U+ GARDEN, BE-MYSELF, BINGNENG, CZ-KJ, DEBS DIRECT, FUXUAN115, GIFMORE, MAOHE, SHENZHEN SPAN TECHNOLOGY CO., LTD., TIAYIA FASHION HOME, WETRYBEST, YINGYI VERLA, ZHIXIONGLI, ZWINNIRD, SHENZHEN HONGFU WUZHOU TECHNOLOGY CO., LTD, SHENZHEN GREINIJIA TRADING CO., LTD, AUDREY BEAUTY, BOTE LLC, HXUUAE LLC, JASPER, JUNHUI TRADING CO., LTD,

Civil Action No.

**FILED UNDER SEAL**

MMOLECULE, PPROTON, QI XUN HA BEAUTY  
CO., LTD, SWONUK, TUOFENG CO. LTD, VASYL  
FLAGSHIP STORE, and WANGHERO,

Defendants.

## **COMPLAINT FOR DAMAGES AND INJUNCTIVE RELIEF**

BROADWAY PINE BRANDS LLC, a Delaware limited liability company (“Plaintiff”), hereby sues Defendants, the Individuals, Partnerships, and Unincorporated Associations identified in the Caption and which are set forth in **Schedule “A”** hereto (collectively “Defendants”). This is a single-count complaint for patent infringement. Defendants have willfully infringed one or more of the claims of U.S. Patent No. 11,154,128 (“Plaintiff’s Patent” or “the ‘128 Patent”) by offering for sale, selling, and distributing knock-off versions of Plaintiff’s SLIDEAWAY® toy bin (“Infringing Products”) through an interactive commercial internet store operating on at least one of the Amazon.com, eBay.com, Aliexpress.com, Joybuy, Temu, Walmart.com, or wish.com e-commerce platforms (“Third Party Service Provider(s)”). In support of its claims, Plaintiff allege as follows:

### **NATURE OF THE ACTION**

1. Michael Scotese is an executive of the Plaintiff company, BROADWAY PINE BRANDS LLC, the 100% owner of the combined assets of Adam Hinkle, Dana Sue Hinkle, and Hinkle Direct, LLC d/b/a Creative QT, the original company that developed and marketed the product at issue in this case (i.e., the SLIDEAWAY® toy bin). Borne from the minds of the loving parents of 5 children, the Plaintiff’s patented product solved the challenging problem of cleaning up small toys that a creative child has spread out to explore and play with on the floor. The toys are stored in a decorative storage bin that has a play mat integrated into it. The toys are

spilled from the storage bin onto the integrated play mat and do not escape from the system. The mat is large enough for the child to spread all its toys out but still fits neatly into the storage bin with the toys on it. To clean up, the draw string handles are pulled to gather the mat with the toys back into the storage bin. The lid of the bin is then closed and the decorative storage bin, holding the play mat, and all the toys, may be placed in the room as desired. Today, the product is sold by Plaintiff under the brand name SLIDEAWAY<sup>®</sup> toy bin (“Plaintiff’s Product”).

2. Defendants have offered for sale, sold, and distributed knock-off versions of the Plaintiff’s Product which infringe at least one claim of the Plaintiff’s Patent and some are using Plaintiff’s Mark without license or permission to sell their knock-offs. Moreover, Defendants’ sale, distribution, and advertising of the Infringing Product are highly likely to cause consumers to believe that Defendants are offering a genuine version of Plaintiff’s Product when they are not. Shown below are example types of Infringing Product offered for sale by several Defendants:

### **PLAINTIFF’S PRODUCT**



**INFRINGING LISTING OF DEFENDANT oatslikeme**



**IN INFRINGING LISTING OF DEFENDANT Jasper**



**INFRINGING LISTING OF DEFENDANT Lovely home furnishing Store**



## INFRINGEMENT LISTING OF DEFENDANT McPhee Store



## INFRINGEMENT LISTING OF DEFENDANT MAOHE



3. As poorly designed and manufactured products, the flimsiness of Defendants' Infringing Products may disappoint a customer who may give Plaintiff's product a bad review on one or more online platforms.

4. Defendants' Infringing Products threaten to destroy the reputation of high quality that Plaintiff's Products have earned.

5. Plaintiff's Product is marketed and advertised extensively including on its website [creativeqt.com](http://creativeqt.com) and its storefront on [Amazon.com](http://Amazon.com). The unique features of Plaintiff's Product and the manner in which it is marketed and advertised, including: the distinct photographs, the design, the instructions, the packaging, and the unique presentation of the product, all comprise

Plaintiff's valuable intellectual property ("IP") and all have become distinct in consumers' minds such that consumers associate all of this IP with Plaintiff's Product. Screenshots from Plaintiff's Website and Amazon Store are attached as Complaint **Exhibit 1**.

6. The innovative features of Plaintiff's Product are the subject of U.S. Patent No. 11,154,128 entitled "storage container with an integrated mat". Plaintiff is the sole owner of U.S. Patent 11,154,128, and has not licensed the patent to any individual or entity. A copy of the patent is attached as Complaint **Exhibit 2** ("Plaintiff's Patent"). The Defendants had actual notice of the publication of this patent. The claims as published were the subject of a first office action allowance. Thus, the allowed claims and the published claims were identical. Defendants' infringement began as early as November 21, 2019 (the publication date).

7. Plaintiff sells its toy storage bin under the registered SLIDEAWAY<sup>®</sup> trademark U.S. Reg. No. 5994698 for "fabric sided toy storage container in the nature of a toy box or toy chest having an integrated play mat" in class 20. A copy of the trademark registration certificate and status and ownership record from the United States Patent and Trademark Office is attached as Complaint **Exhibit 3** ("Plaintiff's Mark").

8. On information and belief, Defendants' sale of Infringing Products gives rise to a plausible expectation that discovery will reveal that Defendants' actions all arise from the same transaction, occurrence, or series of transactions. Specifically, on information and belief, Defendants are actively participating in a conspiracy to distribute and sell Infringing Products. For example, Defendants, on information and belief, are working together to manufacture, arrange the manufacture of and/or sell and otherwise distribute the Infringing Products. Moreover, the Infringing Products all infringe on at least one claim of the Plaintiff's Patent and the Infringing Products are the same or substantially similar products.

9. Plaintiff therefore brings this action for Patent Infringement under 35 U.S.C. § 271, and the All Writs Act, 28 U.S.C. § 1651(a).

### **JURISDICTION AND VENUE**

10. This Court has subject matter jurisdiction over this action pursuant to 28 U.S.C. §§ 1331 and 1338.

11. This Court may exercise personal jurisdiction over a non-resident of the State in which the Court sits to the extent authorized by the state's laws. Fed. R. Civ. P. 4(e). Pennsylvania authorizes personal jurisdiction over each Defendant pursuant to 42 Pa. Cons. Stat. § 5322 (a) which provides in pertinent part: “A tribunal of this Commonwealth may exercise personal jurisdiction over a person ... as to a cause of action or other matter arising from such person: (1) Transacting any business in this Commonwealth. Without excluding other acts which may constitute transacting business for the purpose of this paragraph: (ii) The doing of a single act in this Commonwealth for the purpose of thereby realizing pecuniary benefit ... (3) Causing harm or tortious injury by an act or omission in this Commonwealth. (4) Causing harm or tortious injury by an act or omission outside this Commonwealth ... (10) Committing any violation within the jurisdiction of the Commonwealth of any statute, home rule charter, local ordinance or resolution, or rule or regulation promulgated thereunder by any government unit or of any order of court or other government unit.” In the alternative, Federal Rule of Civil Procedure 4(k) confers personal jurisdiction over the Defendants because, upon information and belief, Defendants regularly conduct, transact and/or solicit business in Pennsylvania and in this judicial district, and/or derive substantial revenue from their business transactions in Pennsylvania and in this judicial district and/or otherwise avail themselves of the privileges and protections of the laws of the Commonwealth of Pennsylvania such that this Court's assertion of

jurisdiction over Defendants does not offend traditional notions of fair play and due process, and/or Defendants' illegal counterfeiting and infringing actions caused injury to Plaintiff in Pennsylvania and in this judicial district such that Defendants should reasonably expect such actions to have consequences in Pennsylvania and in this judicial district, for example:

a. Upon information and belief, at all times relevant hereto, Defendants were and/or are systematically directing and/or targeting their business activities at consumers in the United States, including Pennsylvania, through online platforms with Merchant Storefronts (as defined *infra*), via at least one of the online marketplace websites, such as Aliexpress.com, Amazon.com, eBay.com, Joybuy, Temu, Walmart.com, and Wish.com online marketplaces, under the Seller IDs, as well as any and all as yet undiscovered accounts with Merchant Storefronts held by or associated with Defendants, their respective officers, employees, agents, servants and all persons in active concert or participation with any of them ("User Accounts"), through which consumers in the United States, including Pennsylvania, can view the one or more of Defendants' Merchant Storefronts that each Defendant operates, uses to communicate with Defendants regarding their listings for Infringing Products and to place orders for, receive invoices for and purchase Infringing Products for delivery in the U.S., including Pennsylvania, as a means for establishing regular business with the U.S., including Pennsylvania.

b. Upon information and belief, certain Defendants are sophisticated sellers, each operating one or more commercial businesses using their respective User Accounts through which Defendants, their respective officers, employees, agents, servants and all persons in active concert of participation with any of them, operate storefronts to

manufacture, import, export, advertise, market, promote, distribute, offer for sale and/or otherwise deal in products, including the Infringing Products, which are held by or associated with Defendants, their respective officers, employees, agents, servants and all persons in active concert or participation with any of them (“Merchant Storefront(s)”) in wholesale quantities at significantly below-market prices to consumers worldwide, including to those in the U.S., and specifically Pennsylvania.

c. Upon information and belief, Defendants’ Merchant Storefronts reflect multiple sales to consumers all over the world, including repeat sales to consumers in the U.S. and into this judicial district.

d. Upon information and belief, all Defendants accept payment in U.S. Dollars and offer shipping to the U.S., including to Pennsylvania.

e. Upon information and belief, at all times relevant, Defendants have transacted business with consumers located in the U.S., including Pennsylvania, for the sale and shipment of Infringing Products.

f. Upon information and belief, some Defendants are employing and benefiting from substantially similar, paid advertising and marketing and advertising strategies in order to make their Merchant Storefronts selling illegal goods appear more relevant and attractive to search result software across an array of search words, including but not limited to “SLIDEAWAY” and “TOY STORAGE BASKET AND PLAY MAT”. By their actions, Defendants are causing concurrent and indivisible harm to Plaintiff and the consuming public by (i) depriving Plaintiff of its right to fairly compete for space within the various on-line marketplace search results and reducing the visibility of the Plaintiff’s Product on various online marketplaces and/or diluting and driving down the retail

market price for the Plaintiff's Product (ii) causing an overall degradation of the value of the goodwill associated with Plaintiff's Product; and (iii) increasing Plaintiff's overall cost to market its goods and educate consumers about its brand and products.

g. Upon information and belief, Defendants have cooperated, communicated their plans with one another, shared information, purchased their infringing products from the same source, and coordinated their efforts, all in order to create an illegal marketplace operating in parallel to the legitimate marketplace of Plaintiff's and the legally authorized resellers of Plaintiff's genuine goods.

h. Upon information and belief, Defendants are concurrently targeting their infringing activities toward consumers and causing harm in Allegheny County, Pennsylvania.

i. Upon information and belief, many of the Defendants likely reside and/or operate in foreign jurisdictions with lax trademark and patent enforcement systems and are cooperating by creating an illegal stream of infringing and Infringing Goods.

j. Upon information and belief, Defendants are aware of Plaintiff, its genuine SLIDEAWAY<sup>®</sup> Toy Bin, and are aware that their illegal infringing actions alleged herein are likely to cause injury to Plaintiff in the United States, in Pennsylvania and in this judicial district specifically, as Plaintiff conducts substantial business in Pennsylvania.

k. Plaintiff is suffering irreparable and indivisible injury and suffered substantial damages as a result of Defendants' unauthorized and wrongful sale of infringing goods.

12. Venue is proper, *inter alia*, pursuant to 28 U.S.C. § 1391 because, for example:

- a. Upon information and belief, Defendants conduct, transact, and/or solicit business in this judicial district.
- b. Upon information and belief, Defendants or their agent(s) may be found in this district because personal jurisdiction is proper in this district.
- c. Upon information and belief, this is a judicial district in which a substantial part of the events or omissions giving rise to the infringement claims occurred, or a substantial part of the property that is the subject of the action is situated.
- d. Defendants not resident in the United States may be sued in this judicial district because personal jurisdiction is proper in this district.

### **THE PLAINTIFF**

13. Plaintiff, Broadway Pine Brands LLC, is a Delaware limited liability company and has its principal place of business at 113 Cherry Street, PMB 89249, Seattle, Washington 98104-2205 U.S.

14. Plaintiff is, in part, engaged in the business of manufacturing and distributing throughout the world, including within this district, the SLIDEAWAY<sup>®</sup> Toy Bin, through its website, creativeqt.com, its authorized storefront on amazon.com, and various retail establishments. Defendants, through the sale and offer to sell Infringing Products are directly, and unfairly, competing with Plaintiff's economic interest in the Commonwealth of Pennsylvania and causing Plaintiff harm within this jurisdiction.

15. Like many other brand owners, Plaintiff suffers ongoing daily and sustained violations of its rights at the hands of infringers, such as Defendants herein, who wrongfully reproduce Plaintiff's Products for the twin purposes of (i) duping and confusing the consuming

public and (ii) earning substantial profits from the sale of their Infringing Products. The natural and intended byproduct of Defendants' actions is the erosion and destruction of the goodwill associated with Plaintiff's Products and the destruction of the legitimate market sector in which Plaintiff operates.

16. The recent explosion of counterfeiting and infringement over the Internet, including through online marketplace platforms, has created an environment that requires brand owners, such as Plaintiff, to expend significant time and money across a wide spectrum of efforts in order to protect both consumers and Plaintiff from the ill effects of confusion and the erosion of the goodwill associated with Plaintiff's brand and products.

### **THE DEFENDANTS**

17. The Defendants are individuals and/or business entities of unknown makeup, each of whom, upon information and belief, either reside or operate in foreign jurisdictions, or (though not foreign) redistribute products from the same or similar sources in those foreign locations. Defendants have the capacity to be sued pursuant to Federal Rule of Civil Procedure 17(b). Defendants target their business activities toward consumers throughout the United States, including within this district, and conduct pervasive business through the operation of, at least, one fully interactive commercial Internet based e-commerce store via, at least one of the Internet based online marketplaces Amazon.com, aliexpress.com, ebay.com, Joybuy, Temu, Walmart.com, and wish.com, all under the Seller IDs.

18. Upon information and belief, the Defendants use aliases in conjunction with the operation of their businesses as set forth in Schedule "A" hereto.

19. Defendants are the past and present controlling forces behind the sale of products infringing at least one claim of the Plaintiff's Patent described herein using at least the Seller IDs.

20. Upon information and belief, Defendants were willfully advertising, offering for sale and selling goods infringing upon at least one claim of the Plaintiff's Patent to consumers within the United States and this district through several fully interactive, commercial Internet websites and Internet based e-commerce stores operating under, at least, the storefronts, the Seller IDs, and any additional domain names, websites and corresponding website URLs or seller identifications and store URL aliases not yet known to Plaintiff. Defendants have purposefully directed some portion of their illegal activities towards consumers in the Commonwealth of Pennsylvania through the advertisement, offer to sell, sale, and/or shipment of Infringing Products into the Commonwealth.

21. Defendants have registered, established or purchased, and maintained the online marketplace website storefronts and Seller IDs. Upon information and belief, Defendants have engaged in fraudulent conduct with respect to the registration of the storefronts and Seller IDs by providing false and/or misleading information to the Internet based e-commerce platforms where they offer for sale and/or sell, during the registration or maintenance process related to their respective Seller ID. Upon information and belief, Defendants have anonymously registered and maintained some of the Seller IDs for the sole purpose of engaging in illegal infringing activities.

22. Upon information and belief, Defendants will continue to register or acquire new seller identification aliases for the purpose of selling and offering for sale goods infringing at least one claim of the Plaintiff's Patent unless preliminarily and permanently enjoined.

23. Defendants' Internet-based businesses amount to nothing more than illegal operations established and operated in order to infringe the intellectual property rights of Plaintiff.

24. Defendants' business names, i.e., the Seller IDs, associated payment accounts, and any other alias seller identification names used in connection with the sale of goods infringing on at least one claim of the Plaintiff's Patent are essential components of Defendants' online activities and are the means by which Defendants further their infringement scheme and cause harm to Plaintiff.

### **COMMON FACTUAL ALLEGATIONS**

#### **Plaintiff and Its Innovative SLIDEAWAY® Toy Bin**

25. The Plaintiff's Product is an innovative integrated toy storage container and play mat combination that permits the user to pour small toys from the container onto the play mat. By pulling the storage bin handles the play mat retracts back into the storage bin with all the toys. The storage bin lid is closed and the bin and toy clean-up is complete. The Plaintiff's Product, pictured below, retails for \$64.99:



26. On October 26, 2021, the U.S. Patent and Trademark Office issued the '128 patent, the claims of which protect Plaintiff's Product. The Plaintiff's Patent has never been assigned or licensed to any of the Defendants in this matter. The Defendants had actual notice of the Plaintiff's Patent when it was published on November 21, 2019. The Plaintiff's Patent issued after a first office action allowance with the original published claims and no amendments.

27. Plaintiff's Product has been featured in videos, articles, or podcasts by numerous media outlets, including: *The New York Times*, *Good Housekeeping*, *ABC's Good Morning America*, *NBC's Today Show*, and *Scary Mommy*.

### **Defendants' Wrongful and Infringing Conduct**

28. Upon information and belief, Defendants are, through at least the Internet based e-commerce stores operating under the Seller IDs, promoting, selling, offering for sale and distributing goods that willfully infringe at least one claim of the Plaintiff's Patent while marketing their knock-off products in a willful attempt to pass off their knock-off products as the genuine version of Plaintiff's Products.

29. E-commerce sales, including through e-commerce stores like those of Defendants, have resulted in a sharp increase in the shipment of unauthorized products into the United States. *Ference Dec*<sup>1</sup>, Exhibit 1, Excerpts from Fiscal Year 2021 U.S. Customs and Border Protection ("CBP") Intellectual Property Seizure Statistics Report. Over 89% of all CBP intellectual property seizures were smaller international mail and express shipments (as opposed to large

---

<sup>1</sup> Referring to Declaration of Stanley D. Ference III in Support of Temporary Restraining Order, filed herewith.

shipping containers). *Id.* More than half (51%) of CBP seizures originated from mainland China and Hong Kong. *Id.* Counterfeit and pirated products account for billions in economic losses, resulting in tens of thousands of lost jobs for legitimate businesses and broader economic losses, including lost tax revenue.

30. Third party service providers like those used by Defendants do not adequately subject new sellers to verification and confirmation of their identities, allowing counterfeiters to “routinely use false or inaccurate names and addresses when registering with these e-commerce platforms.” *Ference Dec.*, Exhibit 2, Daniel C.K. Chow, *Alibaba, Amazon, and Counterfeiting in the Age of the Internet*, 40 *NW. J. INT’L L. & BUS.* 157, 186 (2020); see also, report on “Combating Trafficking in Counterfeit and Pirated Goods” prepared by the U.S. Department of Homeland Security’s Office of Strategy, Policy, and Plans (Jan. 24, 2020), attached as *Ference Dec.*, Exhibit 3, and finding that on “at least some e-commerce platforms, little identifying information is necessary for a counterfeiter to begin selling” and recommending that “[s]ignificantly enhanced vetting of third-party sellers” is necessary. Counterfeiters hedge against the risk of being caught and having their websites taken down from an e-commerce platform by preemptively establishing multiple virtual store-fronts. *Ference Dec.*, Exhibit 3, at p. 22. Since platforms generally do not require a seller on a third-party marketplace to identify the underlying business entity, counterfeiters can have many different profiles that can appear unrelated even though they are commonly owned and operated. *Ference Dec.*, Exhibit 3, at p. 39. Further, “E-commerce platforms create bureaucratic or technical hurdles in helping brand owners

to locate or identify sources of counterfeits and counterfeiters.” *Ference Dec.*, Exhibit 2, at 186-187.

31. Upon information and belief, Defendants did not obtain an opinion from United States Counsel about the legality of offering for sale each of the Infringing Products.

32. Upon information and belief, Defendants’ Infringing Products are of a quality substantially and materially different than that of Plaintiff’s genuine goods. Defendants, upon information and belief, are actively using, promoting and otherwise advertising, distributing, selling, and/or offering for sale substantial quantities of their Infringing Products with the knowledge and intent that such goods will be mistaken for the genuine high-quality goods offered for sale by Plaintiff despite Defendants’ knowledge that they are without authority to use the subject matter of the Plaintiff’s Patent.

33. Defendants advertise their Infringing Products for sale to the consuming public via Internet based e-commerce stores on, at least, one Internet marketplace using at least the Seller IDs. In so advertising these goods, Defendants improperly and unlawfully infringe at least one claim of the Plaintiff’s Patent without Plaintiff’s permission.

34. As part of their overall infringement scheme, Defendants are, upon information and belief, concurrently employing and benefitting from substantially similar advertising and marketing strategies based, in large measure, upon an illegal use of infringements of the Plaintiff’s Patent in order to make their e-commerce stores selling illegal goods appear more relevant and attractive to consumers online. By their actions, Defendants are contributing to the creation and maintenance of an illegal marketplace operating in parallel to the legitimate marketplace for Plaintiff’s genuine goods. Defendants are causing individual, concurrent and indivisible harm to Plaintiff and the consuming public by (i) depriving Plaintiff and other third

parties of their right to fairly compete for space within search engine results and reducing the visibility of Plaintiff's genuine goods on the World Wide Web, (ii) causing actual consumer confusion, (iii) harm to Plaintiff's reputations, including tarnishing its status as the innovator in this market, (iv) an overall degradation of the value of the goodwill associated with the Plaintiff's brand, and (v) increasing Plaintiff's overall cost to market its goods and educate consumers about its brand via the Internet.

35. Plaintiff confirmed that Defendants were and/or are still currently offering for sale and/or selling Infringing Products for sale to the consuming public via Internet based e-commerce stores on, at least, one Internet marketplace using at least the Seller IDs and that Defendants provide shipping and/or have actually shipped Infringing Products to customers located within this judicial district.

36. There is no question that the Infringing Product itself and the manner in which it is marketed is designed to confuse and mislead consumers into believing that they are purchasing Plaintiff's Product or that the Infringing Product is otherwise approved by or sourced from Plaintiff, thereby trading on the goodwill and reputation of Plaintiff.

37. Upon information and belief, at all times relevant hereto, Defendants in this action had full knowledge of Plaintiff's ownership of the Plaintiff's Patent. Defendants' use of the patent is without Plaintiff's consent or authorization.

38. Defendants are engaging in the above-described illegal infringing activities knowingly and intentionally or with reckless disregard or willful blindness to Plaintiff's rights for the purpose of infringing the Plaintiff's Patent and trading on Plaintiff's goodwill and

reputation. If Defendants' intentional infringing activities are not preliminarily and permanently enjoined by this Court, Plaintiff and the consuming public will continue to be harmed.

39. Defendants' above identified infringing activities are likely to cause confusion, deception, and mistake in the minds of consumers before, during, and after the time of purchase. Moreover, Defendants' wrongful conduct is likely to create a false impression and deceive customers, the public, and the trade into believing there is a connection or association between Plaintiff's Products and Defendants' Infringing Products, which there is not.

40. Upon information and belief, Defendants' payment and financial accounts are being used by Defendants to accept, receive, and deposit profits from Defendants' infringing activities connected to their Seller IDs and any other alias e-commerce stores, photo albums, seller identification names, domain names, or websites being used and/or controlled by them.

41. Further, upon information and belief, Defendants are likely to transfer or secret their assets to avoid payment of any monetary judgment awarded to Plaintiff.

42. Plaintiff has no adequate remedy at law. Plaintiff is suffering irreparable injury and have suffered substantial damages as a result of Defendants' unauthorized and wrongful infringement of at least one claim of the Plaintiff's Patent. If Defendants' infringing activities are not preliminarily and permanently enjoined by this Court, Plaintiff and the consuming public will continue to be harmed.

43. The harm and damages sustained by Plaintiff has been directly and proximately caused by Defendants' wrongful reproduction, use, advertisement, promotion, offers to sell, and sale of their Infringing Products.

## **The Scope of Defendants' Activities**

44. Upon information and belief, each Defendant operates more than one merchant storefront.

45. Upon information and belief, each Defendant operates merchant storefronts across multiple e-commerce marketplaces.

46. The profit per Infringing Product unit sold is at least \$30.00.

47. Upon information and belief, each Defendant has sold more than 150,000 units of the Infringing Product.

48. Upon information and belief, each Defendant's profits from the sale of the Infringing Products totals more than \$100,000.

49. Upon information and belief, each Defendant's profits from the sale of the Infringing Products totals more than \$300,000.

50. Upon information and belief, each Defendant's profits from the sale of the Infringing Products totals more than \$2,000,000.

### **COUNT I – PATENT INFRINGEMENT (35 U.S.C. § 271 (a))**

51. Plaintiff hereby adopts and re-alleges the allegations set forth in the preceding paragraphs as if set forth herein.

52. Plaintiff owns U. S. Patent No. 11,154,128 entitled "Storage container with an integrated mat". A copy of the patent is attached as Complaint **Exhibit 2**. The allowed claims of Plaintiff's Patent were published on November 21, 2019, as they were the subject of first office action allowance without amendment. At all times relevant hereto, the Plaintiff's Product was

marked in accordance with the Patent Act. Defendants had actual notice of the publication of the Plaintiff's Patent.

53. Each of the Infringing Products that was received was physically examined and infringes at least Claim 1 of the Plaintiff's Product, as more fully detailed and demonstrated by viewing the Claims Chart of **Complaint Exhibit 4** and the photographs and descriptions of each Infringing Product as shown in **Composite Exhibit 1** of the Odell Declaration filed herewith.

54. Defendants have infringed and continue to infringe the Plaintiff's Patent either directly or indirectly through acts of contributory infringement or inducement in violation of 35 U.S.C. § 271, by making, using, selling, importing and/or offering to sell Infringing Products, namely the knock-offs that infringe at least one claim of the Plaintiff's Patent.

55. Defendants' infringement, contributory infringement and/or inducement to infringe has injured Plaintiff and it, therefore, is entitled to recover damages adequate to compensate it for such infringement, but in no event less than a reasonable royalty.

56. Defendants' infringement, contributory infringement and/or inducement to infringe has been willful and deliberate because Defendants have notice of or knew of the Plaintiff's Patent and have nonetheless injured and will continue to injure Plaintiff, unless and until this Court enters an injunction, which prohibits further infringement and specifically enjoins further manufacture, use, sale, importation and/or offer for sale of products or services that come within the scope of the Plaintiff's Patent.

57. Based on Defendants' wrongful conduct, Plaintiff is entitled to injunctive relief as well as monetary damages and other remedies as provided by the Patent Act, including damages that Plaintiff has sustained and will sustain as a result of Defendants' illegal and infringing

actions as alleged herein, enhanced discretionary damages and reasonable attorneys' fees and costs.

58. Plaintiff has no adequate remedy at law, and has sustained indivisible injury and damage caused by Defendants' concurrent conduct. Absent an entry of an injunction by this Court, Defendants will continue to wrongfully reap profits and Plaintiff will continue to suffer irreparable injury to its goodwill and business reputation, as well as monetary damages.

59. Based on Defendants' wrongful conduct, Plaintiff is entitled to injunctive relief, Plaintiff's actual damages and Defendants' profits in an amount to be proven at trial, enhanced discretionary damages for willful infringement, and reasonable attorneys' fees and costs.

### **PRAYER FOR RELIEF**

WHEREFORE, Plaintiff demands judgment on all Counts of this Complaint and an award of equitable relief and monetary relief against Defendants as follows:

a. Entry of temporary, preliminary and permanent injunctions pursuant to 35 U.S.C. § 283, and Federal Rule of Civil Procedure 65 enjoining Defendants, their agents, representatives, servants, employees, and all those acting in concert or participation therewith, from manufacturing or causing to be manufactured, importing, advertising or promoting, distributing, selling or offering to sell their Infringing Products.

b. Entry of an Order that, upon Plaintiff's request, any Internet marketplace website operators and/or administrators that are provided with notice of the injunction, including but not limited to the online marketplaces Amazon.com, aliexpress.com, eBay.com, Joybuy, Temu, Walmart.com, and wish.com, identify any e-mail address known to be associated with Defendants' respective Seller ID, and cease facilitating access to any or all e-commerce stores

through which Defendants engage in the promotion, offering for sale, and/or sale of Infringing Products.

c. Entry of an Order that, upon Plaintiff's request, any Internet marketplace website operators and/or administrators who are provided with notice of the injunction, including but not limited to the online marketplaces Amazon.com, aliexpress.com, eBay.com, Joybuy, Temu, Walmart.com, and wish.com, permanently remove any and all listings offering for sale Infringing Products via the e-commerce stores operating under the Seller IDs, including any and all listings linked to the same seller or linked to any other alias seller identification name being used and/or controlled by Defendants to promote, offer for sale and/or sell Infringing Products.

d. Entry of an Order that, upon Plaintiff's request, any Internet marketplace website operators and/or administrators who are provided with notice of the injunction, including but not limited to the online marketplaces Amazon.com, aliexpress.com, eBay.com, Joybuy, Temu, Walmart.com, and wish.com, immediately cease fulfillment of and sequester all goods of each Defendant or other Seller under a Seller ID offering for sale the Infringing Product in its inventory, possession, custody, or control, and surrender those goods to Plaintiff.

e. Entry of an Order awarding Plaintiff damages adequate to compensate for the infringement of its patent, but in no event less than a reasonable royalty for the use made of the invention by the Defendants, together with interest and costs as fixed by the Court pursuant to 35 U.S.C. § 284 and that the award be trebled as provided for under 35 U.S.C. §284.

f. Entry of an Order finding that this case is exceptional and an award to Plaintiff of its attorney fees and costs as provided by for under 35 U.S.C. § 285.

g. Entry of an Order that, upon Plaintiff's request, any financial institutions, payment processors, banks, escrow services, money transmitters, or marketplace platforms, and their related companies and affiliates, identify and restrain all funds, up to and including the total amount of judgment, in all financial accounts and/or sub-accounts used in connection with the Seller IDs or other domain names, alias seller identification names, or e-commerce store names or store URLs used by Defendants presently or in the future, as well as any other related accounts of the same customer(s) and any other accounts which transfer funds into the same financial institution account(s), to be surrendered to Plaintiff in partial satisfaction of the monetary judgment entered herein.

h. Entry of an award of pre- and post-judgment interest on the judgment amount.

i. Entry of an order for any further relief as the Court may deem just and proper.

**DEMAND FOR JURY TRIAL**

Plaintiff respectfully demand a trial by jury on all claims.

Respectfully submitted,

Dated: October 10, 2023

/s/ Stanley D. Ference III

Stanley D. Ference III

Pa. ID No. 59899

courts@ferencelaw.com

Brian Samuel Malkin

Pa. ID No. 70448

bmalkin@ferencelaw.com

FERENCE & ASSOCIATES LLC

409 Broad Street

Pittsburgh, Pennsylvania 15143

(412) 741-8400 - Telephone

(412) 741-9292 - Facsimile

Attorneys for Plaintiff

**LISTING OF EXHIBITS**

- Exhibit 1 .....Screenshots from Plaintiff’s Website and Amazon Store
- Exhibit 2.....U.S. Patent No. 11,154,128
- Exhibit 3.....U.S. Trademark Reg. No. 5994698
- Exhibit 4.....Claims Chart for U.S. Patent No. 11,154,128

## Schedule "A"

### Defendants with Store Name and Seller ID

Defendant Number	Store/Seller Name	Seller ID
1	oatslikeme	2226011197359
2	BABYS WE	30396119695
3	BeSSLe	634418209282881
4	Best Goods For Home	5084275913503
5	Bubercute	634418209393893
6	Castle Sky	634418211266683
7	Childhood	297185560009
8	DOOMEDHAPPY	4910343474863
9	EffStor	634418210862593
10	Eternity Shop	18444271224
11	HOME HAVE FUN	634418210865351
12	Hoom Journal	634418209814771
13	HS Fashion	725723666807
14	Jiaqi home decoration	3037950035924
15	JJY Home	5680933947720
16	Joy and peace	634418211536759
17	Lie flat	6168057423442
18	OverFlight	5470357509305
19	Panda Pet Supplies	111775825809
20	Perfect Boutique Gift	634418209474836
21	SS BAG	20579235444
22	Taole household daily	3836049340583
23	Xinyi home life	114554890681
24	Yuze Commerce	4532226409081
25	Z L M	324951136695
26	AP Warmmer Household	1102735257
27	BAKINGCHEF Store	1100928675
28	Blite Official Store	1101333666
29	CACILLO 01 Store	1103043480
30	CACILLO Flagship Store	1102732147
31	Glutinous Life Store	1102409387
32	Holiday Store	1102014993

<b>Defendant Number</b>	<b>Store/Seller Name</b>	<b>Seller ID</b>
1	oatslikeme	2226011197359
2	BABYS WE	30396119695
3	BeSSLe	634418209282881
4	Best Goods For Home	5084275913503
5	Bubercute	634418209393893
6	Castle Sky	634418211266683
7	Childhood	297185560009
33	Home Have Fun Store	1102896345
34	HomeLife Store	1101891485
33	Kingbombs Store	1101781396
36	Kirin Household Products Store	1102108826
37	Life Kitchen Home Store	1102168687
38	Lovely home furnishing	1102055155
39	Luckima Home-Storage	1101441432
40	McPhee Store	1101828762
41	MIMIGO Store	1101555865
42	MJ Smile Life Store	1102178728
43	MYOBO Storage Store	1102802919
44	RUICHENG OFFICIAL Store	1102304646
45	Shop1102311339 Store	1102311340
46	Shop1102627453 Store	1102627454
47	Shop1102637489 Store	1102633557
48	Shop1102693333 Store	1102693334
49	Shop1102800715 Store	1102801674
50	Shop1102994646 Store	1103000250
51	SHUYA Store	1100780537
52	Space Management Store	1102119441
53	star moon Store	1102650876
54	Starfish baby Store	1101802219
55	Super-Rich Homesupply Store	1101383496
56	XiuXin Store	1102867104
57	Y space Store	1102024464
58	Yaloo Charms Store.	1100483768
59	YHSMTG Two Store	1101879192
60	YJY Home Collection Store	1102410396
61	ZYJJ Store	1101820645

<b>Defendant Number</b>	<b>Store/Seller Name</b>	<b>Seller ID</b>
1	oatslikeme	2226011197359
2	BABYS WE	30396119695
3	BeSSLe	634418209282881
4	Best Goods For Home	5084275913503
5	Bubercute	634418209393893
6	Castle Sky	634418211266683
7	Childhood	297185560009
62	5U+ Garden	A1FL4ZI5WG3U2J
63	Be-MySelf	ANKB1M5QJ83N8
64	bingneng	ATLMC1D70XVXR
65	CZ-KJ	A37Q4R7Y1TDRX6
66	Debs Direct	A2BYWZ00A3JOF5
67	FUXUAN115	A11L872DHOL45A
68	Gifmore	AL7E8BVK56KOT
69	MAOHE	A31N40BLZRHPI4
70	Shenzhen span Technology Co., Ltd.	ATAEVXT6UVBQ6
71	TIAYIA FASHION HOME	A2EBDYW01WUAIP
72	Wetrybest	A32ETYWNFCF8VG
73	YINGYI verla	A3GO44XH4LSOQN
74	ZHIXIONGLI	A2UBX46Q8OW3LC
75	ZWINNIRD	A2W4UFAHKF1941
76	Shenzhen Hongfu Wuzhou Technology Co., LTD	9324
77	Shenzhen Greinijia trading Co., LTD	14080
78	Audrey Beauty	101340604
79	BOTE LLC	101242499
80	HXUUAELLC	101341786
81	Jasper	101267936
82	Junhui Trading Co., Ltd	101253947
83	MMolecule	101367180
84	PProton	101290398
85	Qi Xun Ha Beauty Co., ltd	101282044
86	Swonuk	101095000
87	TUOFENG Co. Ltd	101280342
88	VASYL Flagship store	101213681
89	Wanghero	101302606

# **EXHIBIT 1**

## Excerpts from Plaintiff's Website

<https://creativeqt.com/products/slideaway-toy-storage-basket-and-play-mat>

**creative QT** BUNDLES SHOP ▾ ABOUT ▾ BLOG 0



Our Products Have Been Featured On:





### What Parents are Saying About SlideAway®

*"BIG time saver."*

*"The best solution to LEGO clutter on the market"*

*"This thing is AMAZING"*

 Lifetime Workmanship Guarantee

 Thousands of 5-Star Reviews on Amazon

 Family-Owned Small Business in the U.S.

 Fast Shipping in the United States

**creative QT** BUNDLES SHOP ▾ ABOUT ▾ BLOG 0

### All your little toys can finally have a home!

We get it, kids make constant messes, your home never feels clean, and toy clutter is everywhere! Your kids spread the same toys out again and again making cleaning up a never-ending job. It takes HOURS every week just to keep up.

You deserve a clean home just like other busy parents. The SlideAway® stops the spread of kid toy clutter and saves you hours cleaning up every week. Keep your home tidy with QUALITY, STYLISH TOY STORAGE. This is no ordinary toy storage! It has a large integrated playmat to clean up in seconds. Just Pour, Play, and SlideAway®.

### SlideAway® - Toy Storage Basket & Play Mat

**SlideAway Basket**  
Perfect for whatever spreads across the floor each day

## Excerpts from Plaintiff's Amazon Store



Creative QT > Slideaway

[Follow](#) [HOME](#) [PEEL 'N STICK BASEPLATES](#) [STUFF 'N SIT](#) [SLIDEAWAY](#) [STORYBRICKS](#) [CHORE STICKS](#) [BASEPLATES](#) [PLAY-UP WALL PANEL](#) [MAGPLATES](#) [MORE](#)



### SlideAway Basket

No ordinary toy basket, the SlideAway has an attached play mat, and toys slide away for storage with a pull of the handle.

**\$49<sup>99</sup>**

Only 2 left in stock - order soon.



The SlideAway from Creative QT is revolutionary toy storage at its finest. Its exceptional quality is backed by Creative QT's lifetime commitment to quality workmanship & materials.

### Mini SlideAway

Take toys with you on-the-go. Pour toys right onto the integrated tabletop play mat.

**\$19<sup>99</sup>** 

 Quick look



Play on-the-go has never been so easy! Take toys, snacks and more on-the-go with our mini SlideAway. Simply tip the toys out on the tabletop, play, and when finished just slide toys back into the bag.





### Creative QT - SlideAway Toy Storage Organizer & Play Mat for Kids - Organizer Storage Bin for Toys - Kids Toy Box for Boys & Girls - Playroom Storage - Toy Holders for Kids Rooms - Grey

Visit the Creative QT Store  
★★★★★ 1,273 ratings

Price: **\$49.99** & FREE Returns

Get \$60 off instantly: Pay **\$0.00** ~~\$49.99~~ upon approval for the Amazon Prime Store Card. No annual fee.

Color: **Heather Grey**



<b>Size</b>	Large
<b>Material</b>	Nylon
<b>Brand</b>	Creative QT
<b>Color</b>	Heather Grey
<b>Closure Type</b>	Zipper
<b>Item Dimensions LxWxH</b>	15 x 15 x 2 inches
<b>Number of Sets</b>	1

**\$49.99**

& FREE Returns

FREE Prime delivery **Thursday, October 28**

Deliver to Christina - Pittsburgh 15237

**Only 2 left in stock - order soon.**

Qty: 1

Add to Cart

Buy Now

Secure transaction

Ships from Amazon

Sold by Creative QT

Return policy: Returnable until Jan 31, 2022

1-Click ordering is not available for this item.

Add a gift receipt for easy returns

Add to List



[Click to see more videos](#)

#### About this item

- ALL-IN-ONE PLAY SOLUTION** - This compact toy basket helps you effortlessly clean up and store your kids' collection of building bricks and other small toys in seconds. Simply spread out the mat for play, then pull the drawstring handles when finished
- TIDY IN A FLASH** - Let your kids spill, scatter, and build - cleanup is a breeze! This combo storage basket with integrated playmat makes it easy to spread out at playtime and quickly tidy up when done. No more picking up toys by the handful
- PLENTY OF ROOM TO PLAY** - Our 52" play mat with 3" lip is big enough for young builders to spread out their bricks or toys without making a mess. The 12" tall, 15" diameter basket holds up to 9 lbs of toys! Keep playroom clutter under control
- MADE TO LAST** - Our sturdy SlideAway toy storage basket, sorting mat, and heavy-duty handles are made to withstand plenty of use and keep your house clean. Comes with a Lifetime Guarantee
- TRUST THE ORIGINAL** - Creative QT is the original developer of the patent-pending SlideAway Basket with matching lid. Our commitment to premium quality and customer satisfaction makes our products the best value for your dollar

[See more product details](#)

Share [Email](#) [Facebook](#) [Twitter](#) [Pinterest](#)

Have one to sell?

[Sell on Amazon](#)

**\$2 off coupon**



XXL Toy Storage Bag with Play Mat | Full Standing Basket +...

★★★★★ 28

\$36.95 [prime](#)

Sponsored

The SlideAway Collection from Creative QT is revolutionary toy storage at its finest. Featuring a built-in play mat that doubles as a play area for sorting toys and 'toy slide' in and out of the basket ... simply Tip, Play, then SlideAway.

Perfect for storing building bricks, magnetic building toys, dress up dolls, toy cars and more. You won't even have time to sing the cleanup song, the patent-pending SlideAway makes cleaning up a five-second job. Little ones love having an identified play space...parents love having everything contained and cleanup as easy as SlideAway!



Featuring two options, the SlideAway Basket and the Mini SlideAway, style meets unparalleled functionality in the SlideAway Collection.

The SlideAway Basket is perfect for what spreads across the floor each day, and the Mini SlideAway for tabletop play.

Pour • Play • SlideAway®



Find the perfect pattern  
to fit your home!

creative **QT**

SlideAway™



Mini SlideAway®

# **EXHIBIT 2**



US011154128B2

(12) **United States Patent**  
**Hinkle**

(10) **Patent No.:** **US 11,154,128 B2**  
(45) **Date of Patent:** **Oct. 26, 2021**

(54) **STORAGE CONTAINER WITH AN INTEGRATED MAT**

USPC ..... 206/216, 575, 579; 141/314, 319; 446/491

See application file for complete search history.

(71) Applicant: **Adam Hinkle**, Spring Grove, IL (US)

(56) **References Cited**

(72) Inventor: **Adam Hinkle**, Spring Grove, IL (US)

U.S. PATENT DOCUMENTS

(73) Assignee: **Broadway Pine Brands LLC**, Seattle, WA (US)

4,020,922	A *	5/1977	Klasel	.....	B01D 35/31
					184/1.5
5,213,141	A *	5/1993	Dorman	.....	B65F 1/0006
					141/10
5,439,109	A *	8/1995	McBride	.....	A45C 7/0077
					174/135
8,060,969	B2 *	11/2011	Jones	.....	A47L 13/16
					15/105
8,490,238	B2 *	7/2013	Sohn	.....	A47K 10/02
					15/209.1
2008/0017529	A1 *	1/2008	Herring	.....	B65D 5/42
					206/216
2008/0264808	A1 *	10/2008	Gostt	.....	A47L 19/00
					206/216
2010/0234819	A1 *	9/2010	McGarity	.....	B65F 1/0006
					604/317

(\*) Notice: Subject to any disclaimer, the term of this patent is extended or adjusted under 35 U.S.C. 154(b) by 316 days.

(21) Appl. No.: **16/528,810**

(22) Filed: **Aug. 1, 2019**

(65) **Prior Publication Data**

US 2019/0350349 A1 Nov. 21, 2019

**Related U.S. Application Data**

(60) Provisional application No. 62/801,131, filed on Feb. 5, 2019.

\* cited by examiner

*Primary Examiner* — Luan K Bui

(74) *Attorney, Agent, or Firm* — Ference & Associates LLC

(51) **Int. Cl.**

<b>B65D 77/00</b>	(2006.01)
<b>A45F 4/02</b>	(2006.01)
<b>A45C 9/00</b>	(2006.01)
<b>B65D 25/28</b>	(2006.01)
<b>B65D 25/02</b>	(2006.01)
<b>A45C 7/00</b>	(2006.01)

(57) **ABSTRACT**

Embodiments of the present invention discloses a storage container with an integrated mat. The storage container includes a receptacle for holding various objects (Eg. toys, crafts, games), and the mat is foldably storable inside the container, wherein the mat is configured in a way such that the mat can be pulled out of the container for performing various activities using the objects, and once done, the objects can be rolled back into the storage container with great ease.

(52) **U.S. Cl.**

CPC ..... **A45F 4/02** (2013.01); **A45C 9/00** (2013.01); **B65D 25/02** (2013.01); **B65D 25/28** (2013.01); **A45C 2007/0004** (2013.01)

(58) **Field of Classification Search**

CPC ..... B65D 25/02; A45C 2007/0004

**20 Claims, 11 Drawing Sheets**

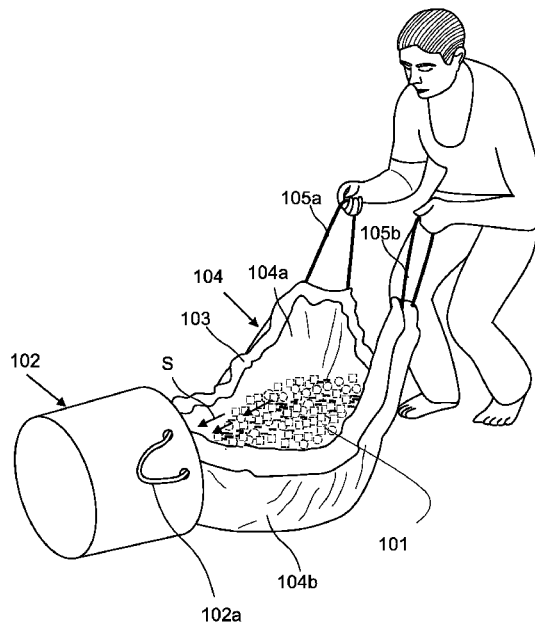

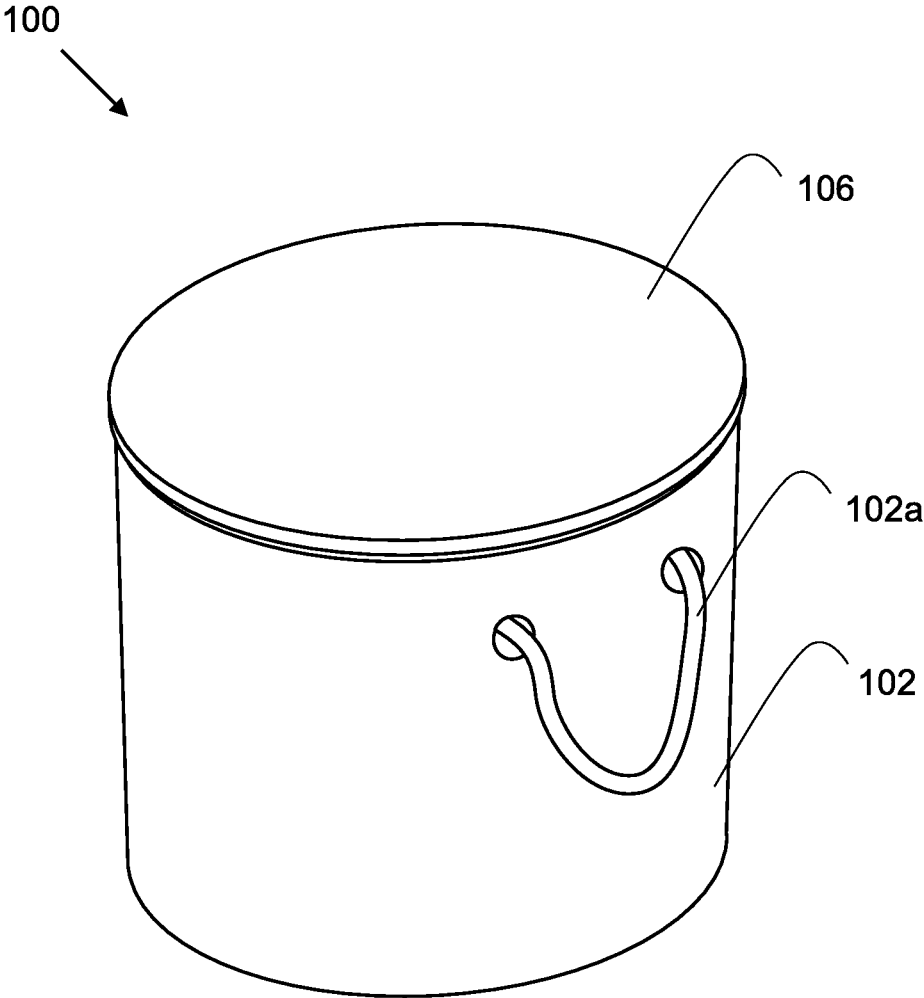

**FIG. 1**

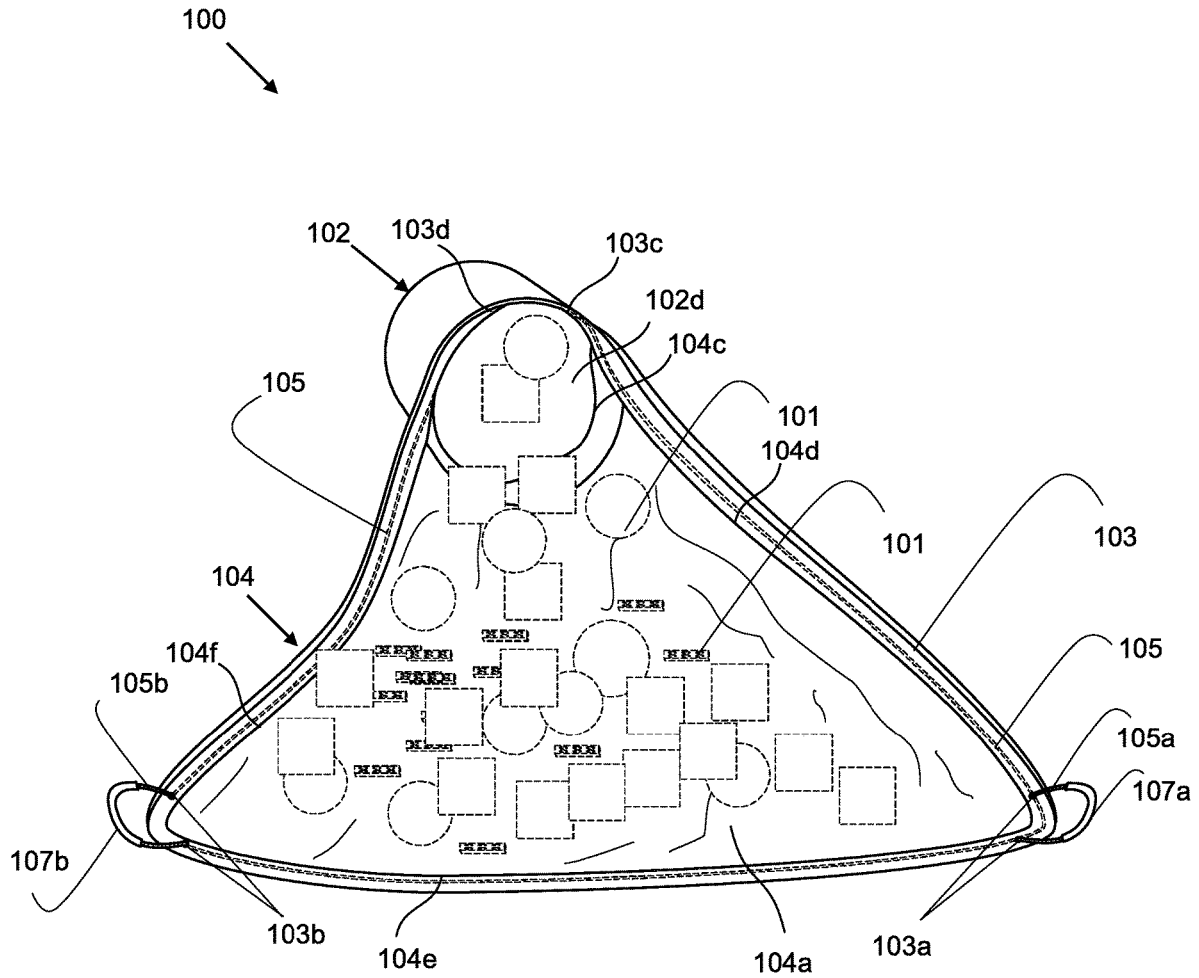

FIG. 2A

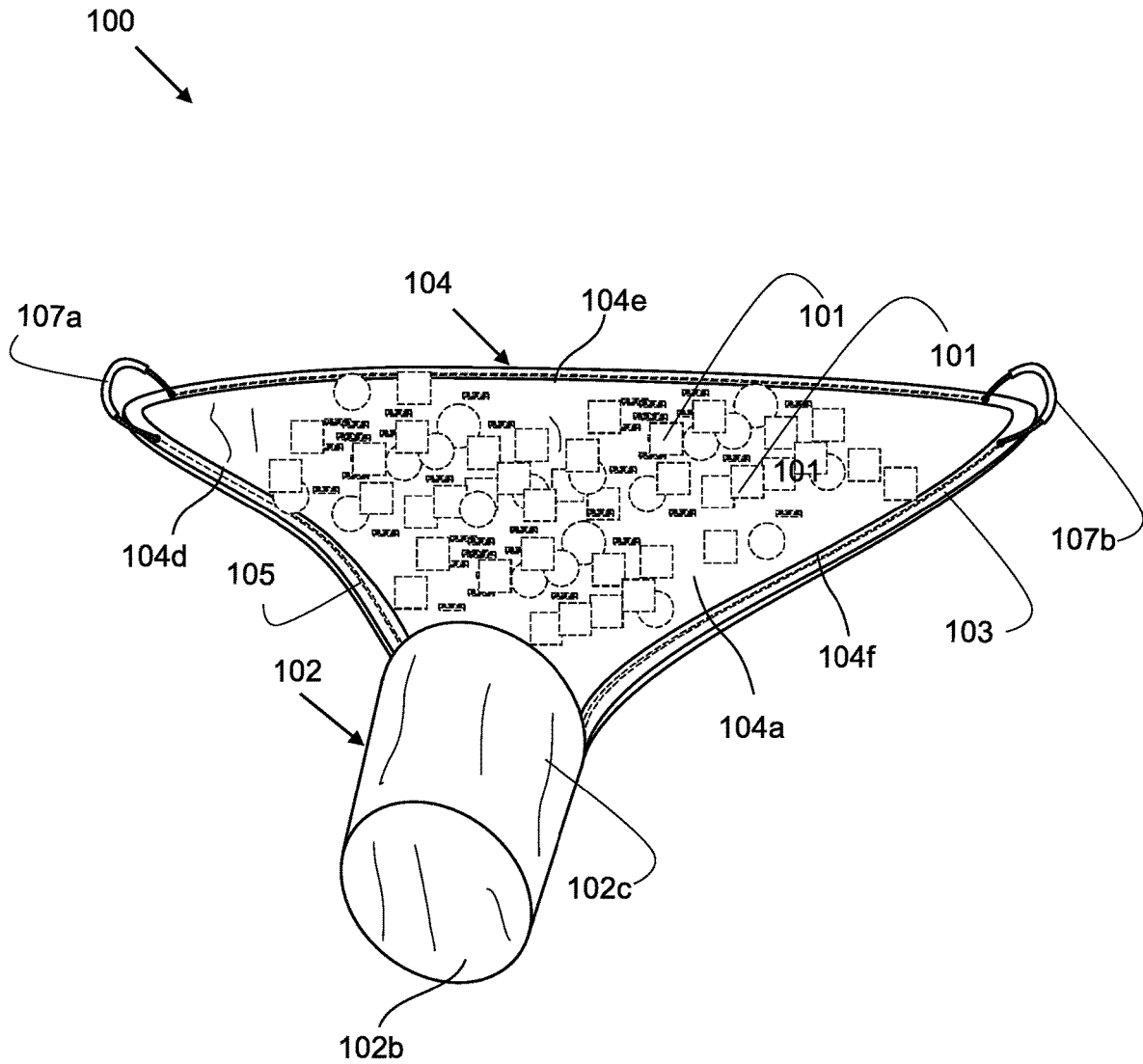
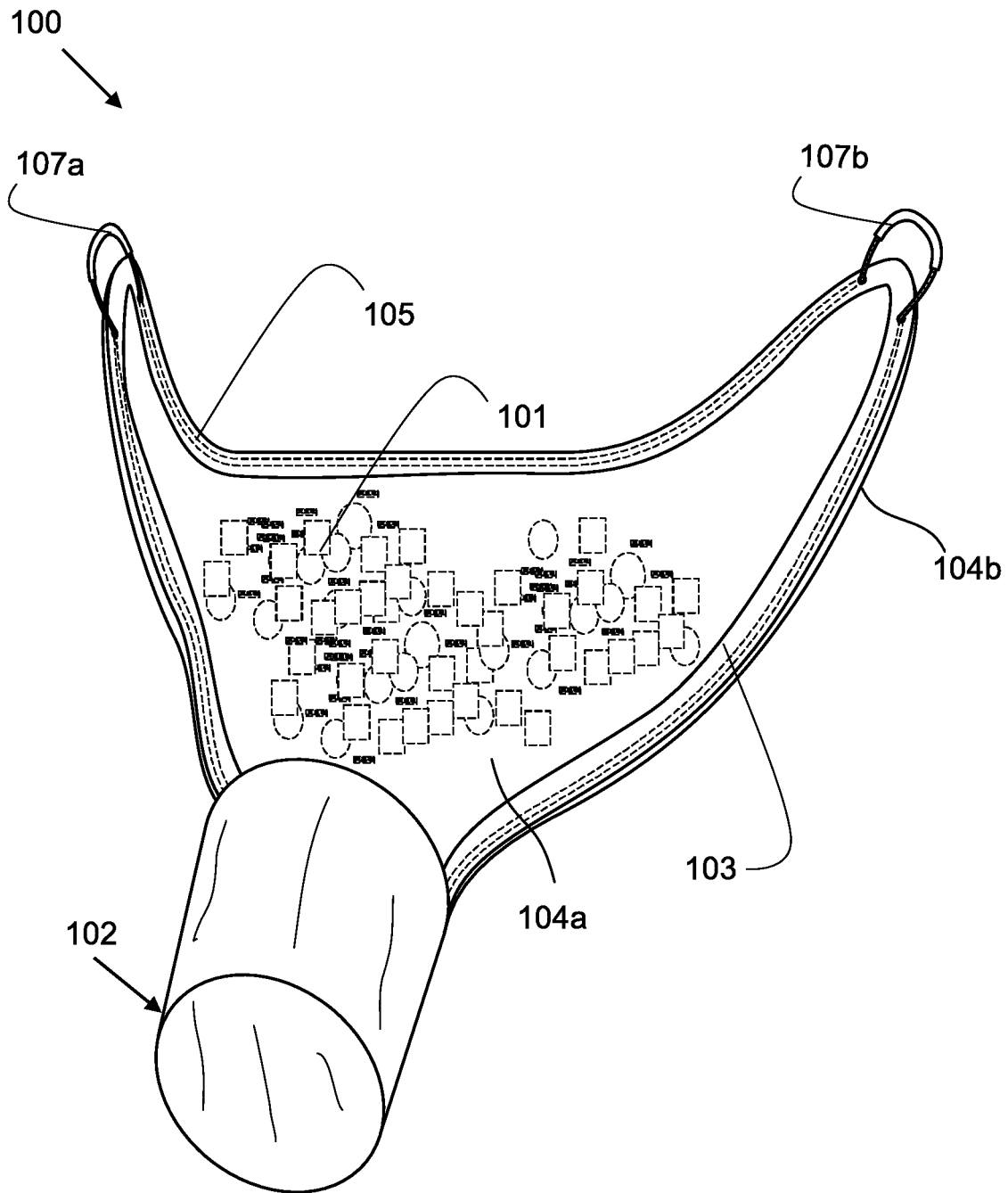
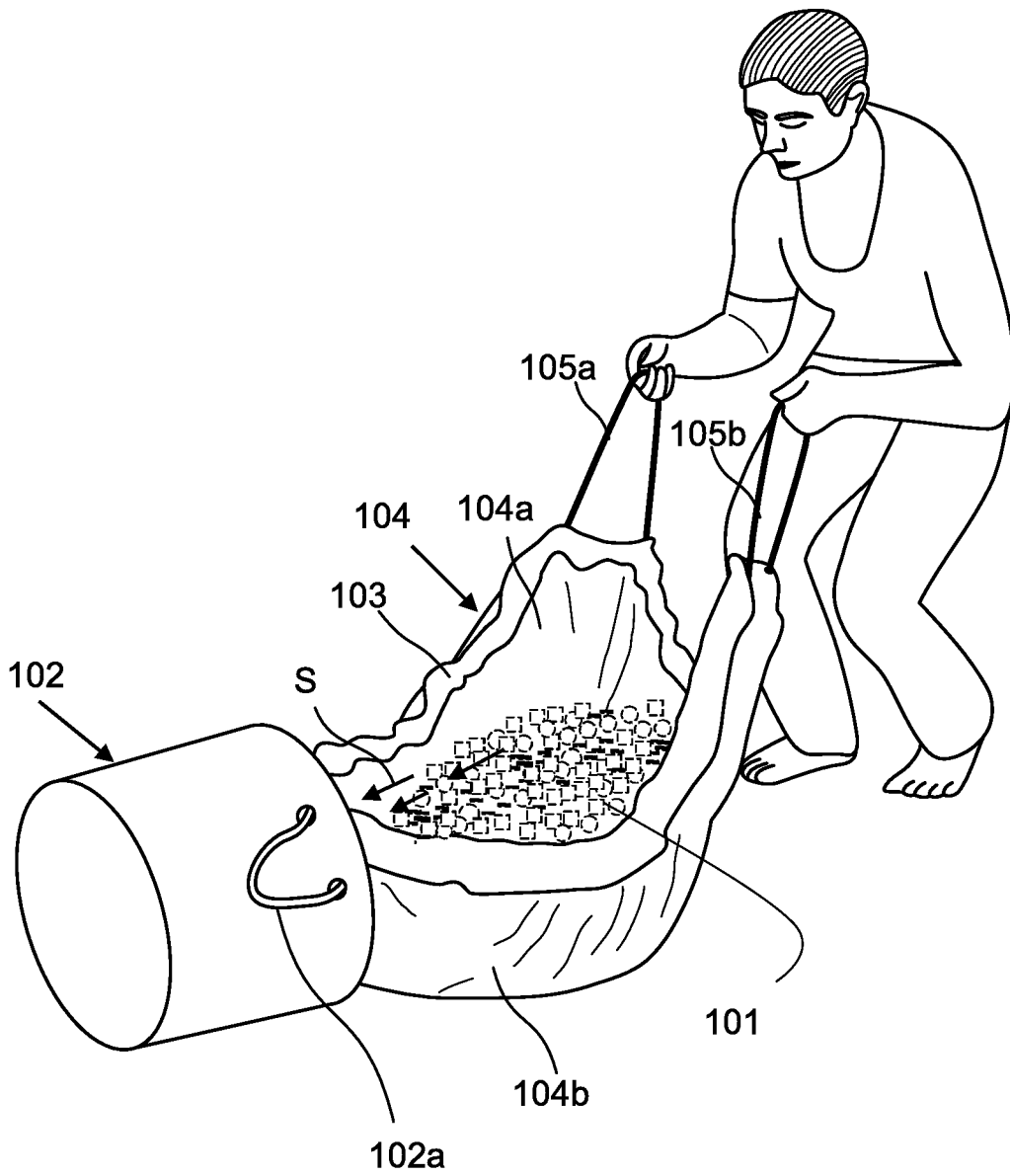

FIG. 2B



**FIG. 3A**



**FIG.3B**

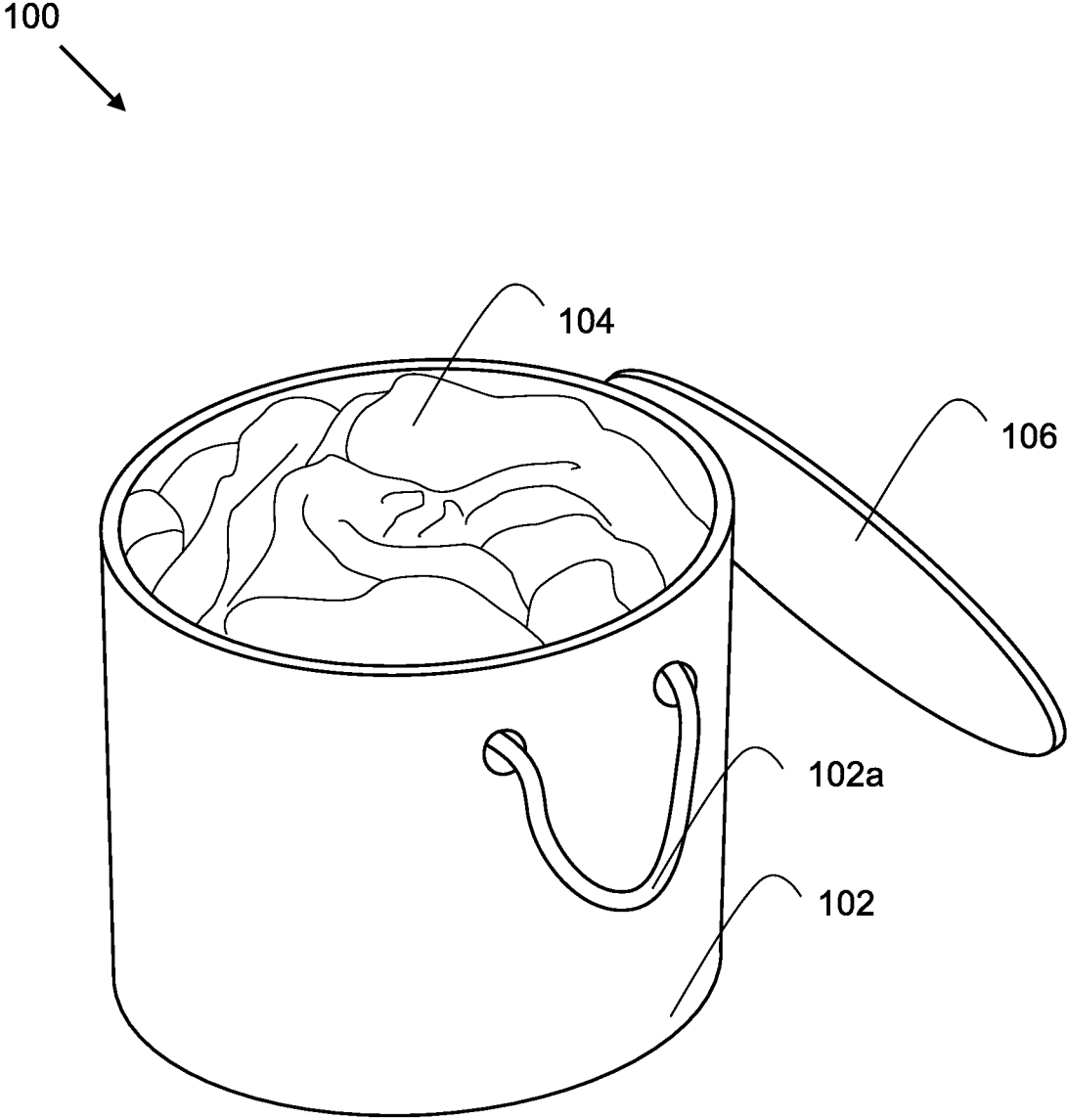

**FIG.4**

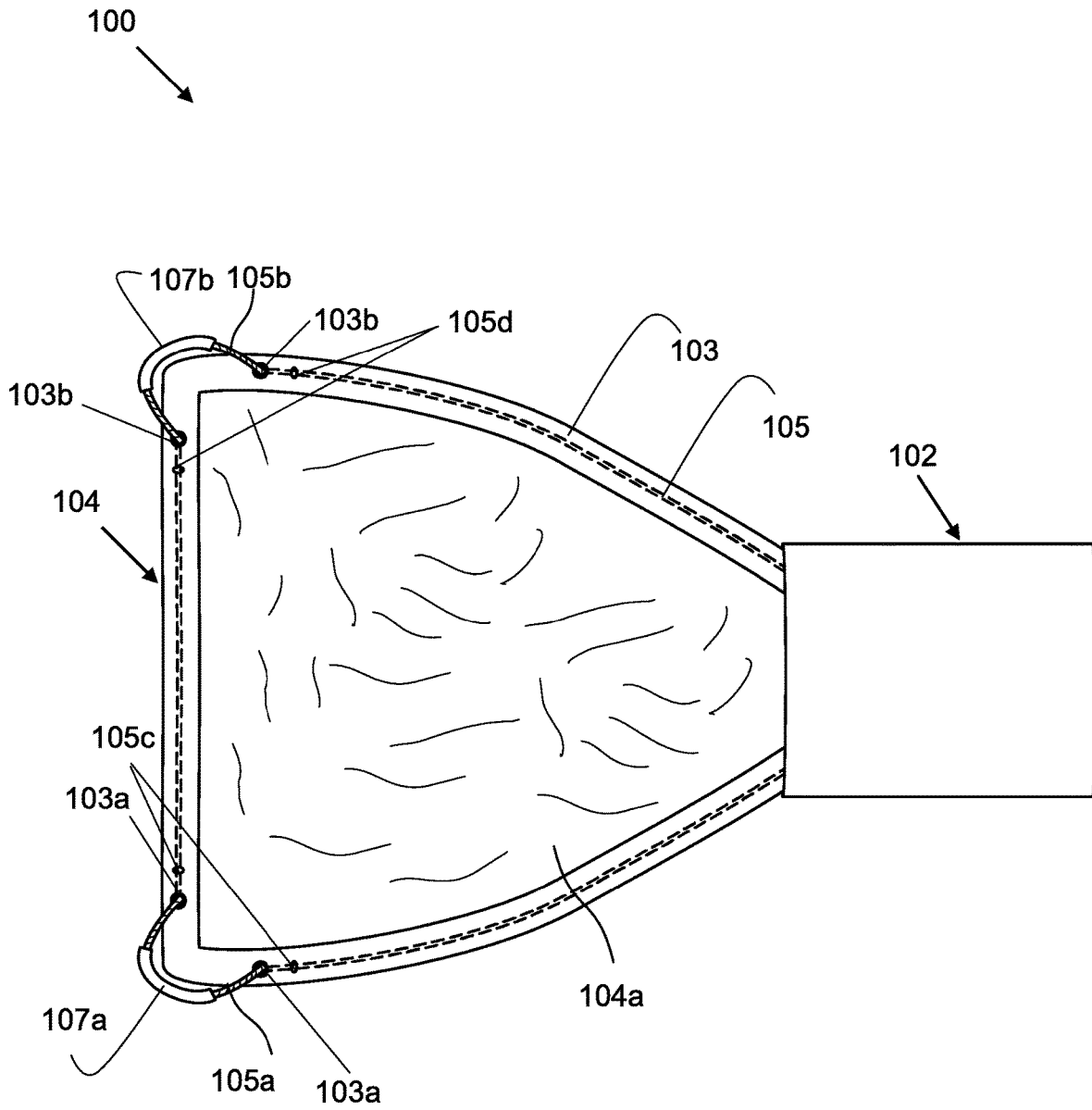

**FIG. 5**

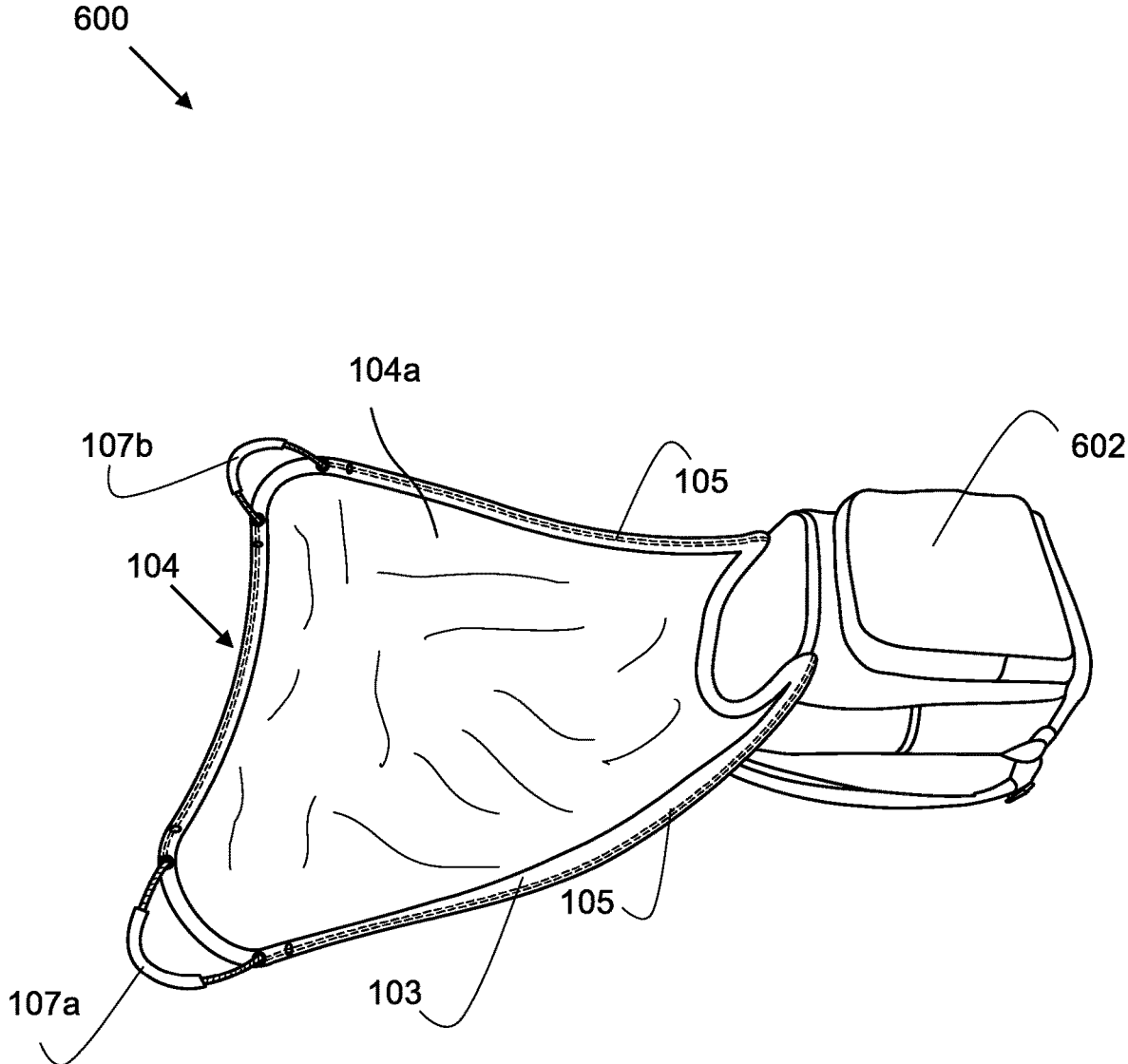

**FIG. 6**



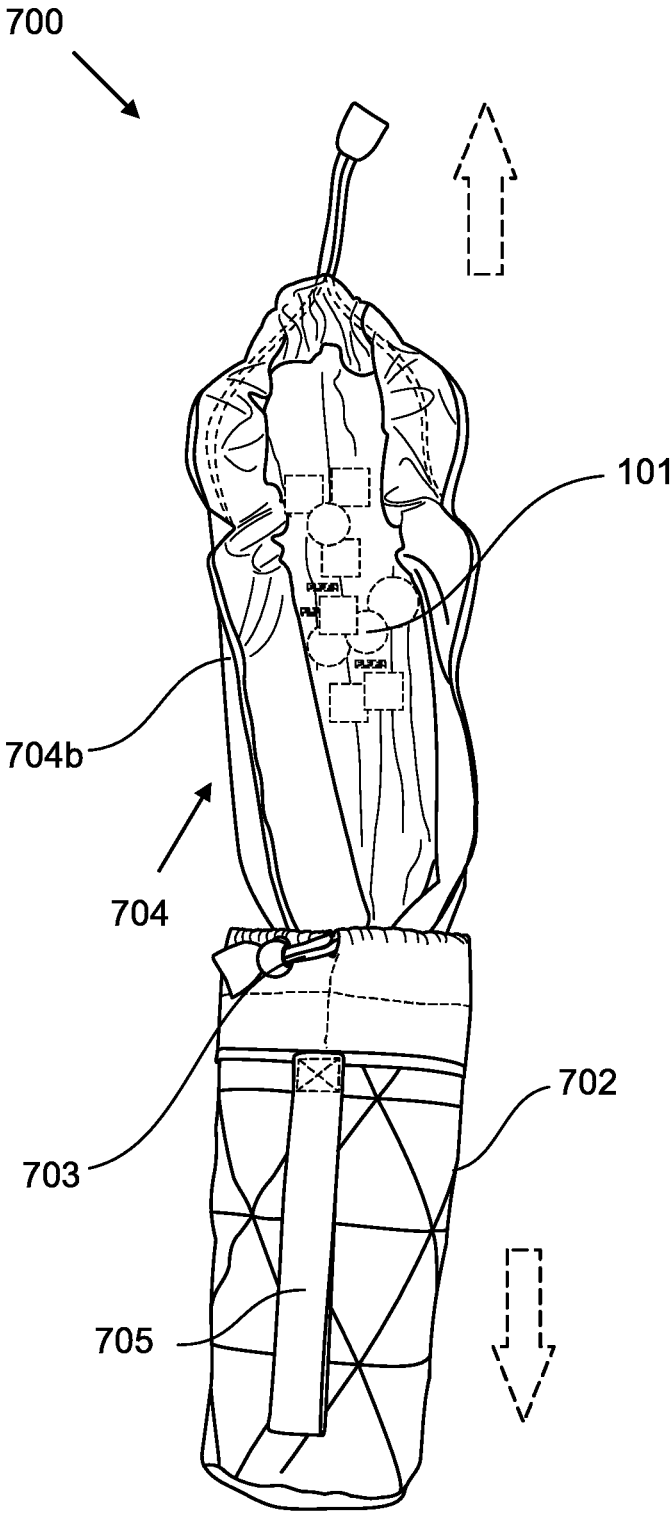
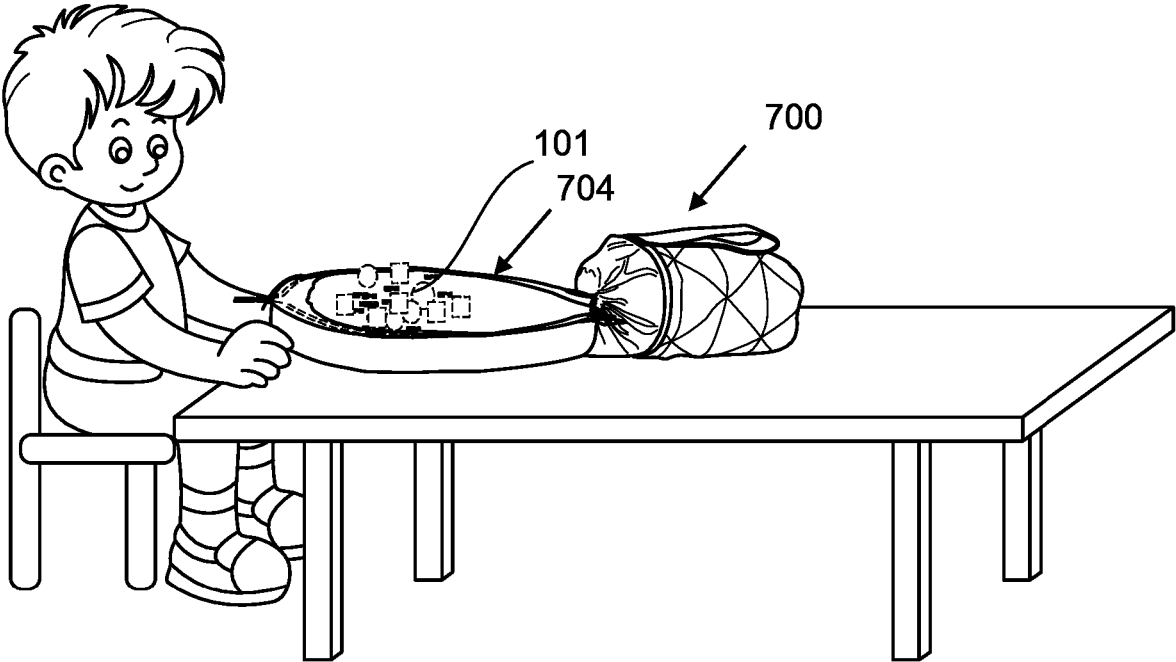

FIG.9



**FIG.10**

## STORAGE CONTAINER WITH AN INTEGRATED MAT

### CROSS-REFERENCE TO RELATED PATENT DOCUMENTS

This patent application claims the benefit of priority of U.S. Provisional Application No. 62/801,131, entitled "STORAGE CONTAINER WITH AN INTEGRATED MAT," filed Feb. 5, 2019, which are hereby incorporated herein by reference in its entirety.

### TECHNICAL FIELD OF INVENTION

This invention relates generally to storage devices and, particularly, to a storage container with an integrated mat. More specifically, the present invention discloses a storage container for holding various objects (Eg. toys), and a mat foldably storable inside the container, wherein the mat is configured in a way such that the mat can be pulled out of the container for performing various activities using the objects, and once done, the objects can be rolled or slide back into the storage container with great ease.

### BACKGROUND

Containers with various shapes and sizes for holding toys, games and/or other objects are known. Also, mats of various sizes and configurations that help kids to play using the toys, games and/or other objects (Eg. crafts material) are known. These containers and mats lack a combination feature that make them a single integrated product for ease of usability.

It is well known that many toys, games and building sets for children can have hundreds of small parts and components. Often times these parts can become scattered and lost when children dump containers full of such parts out on a floor and begin playing and building construction projects. Sometimes such parts end up in traffic areas where they can be stepped on and cause injuries. The invention disclosed herein provides an expandable mat affixed to the container that becomes a play area where toys can be corralled and prevented from being lost.

In the past, several inventors have proposed convertible containers that can serve the purpose of storage for such articles/objects, and an activity mat. For example, U.S. Pat. No. 8,714,389 describes about a convertible device that converts between an activity mat and a storage container to capture and store numerous articles. As an essence, this patent discloses a collapsible storage container that is convertible into an activity mat and convertible back into the storage container whereby the articles used on the activity surface are automatically captured as the sections of the activity mat rise to form the walls of the container.

Further, U.S. Pat. No. 6,146,238 discloses a foldable toy storage container. As described in the patent, the container includes a base member, side members and a top member hinged together to form the container for storage. According to the patent, the base member, side members and top member are movable between a first position forming a box-shaped toy storage container and a second position forming a flat substantially rectangular play area.

Likewise, there are many other references such as U.S. Pat. No. 9,084,459, FR2656992, and KR101234153 that discloses about convertible containers that can serve the purpose of storing various objects or toys, and an activity mat for the users using those objects or toys.

Although several attempts are made in the past to devise convertible containers that can serve the purpose of storage for the objects or toys, and a mat that the kids can use to play with the objects and toys contained therein, none of the devised containers actually provides a user friendly combination feature.

Hence, there is a need for a storage container with an integrated mat, wherein the storage container can hold various objects (Eg. toys), and a mat foldably storable inside the container, wherein the mat is configured in a way such that the mat can be pulled out of the container for performing various activities using the objects, and once done, the objects can be rolled back into the storage container with great ease.

### SUMMARY

According to an embodiment, the storage container with an integrated play mat is provided in the form of a basket with or without a lid. The storage container according to this embodiment includes a receptacle for holding various objects and the integral mat foldably storable inside the container. The mat is configured in a way such that the mat can be pulled out of the container (once the container is opened) for performing various activities by the users (such as a kid) using the objects, and once done, the objects can be rolled back into the storage container with great ease.

According to another embodiment, the storage container with an integrated play mat is provided in the form of a drawstring closure pouch. The storage container according to this embodiment includes a receptacle portion for holding various objects and the integral mat foldably storable inside the container. The mat is configured in a way such that the mat can be pulled out of the container (once the container is opened) for performing various activities by the users (such as a kid) using the objects, and once done, the objects can be rolled back into the storage container with great ease.

According to yet another embodiment, the storage container with an integrated play mat is provided in the form of a backpack. The storage container according to this embodiment includes a receptacle portion in the form of backpack for holding various objects and the integral mat foldably storable inside the container. The mat is configured in a way such that the mat can be pulled out of the container (once the container is opened) for performing various activities by the users (such as a kid) using the objects, and once done, the objects can be rolled back into the storage container with great ease.

These and other features and advantages of the present invention will become apparent from the detailed description below, in light of the accompanying drawings.

### BRIEF DESCRIPTION OF DRAWINGS

The foregoing summary, as well as the following detailed description of preferred embodiments, is better understood when read in conjunction with the appended drawings. There is shown in the drawings example embodiments, however, the application is not limited to the specific system and method disclosed in the drawings.

FIG. 1 shows a storage container with an integrated mat in a closed state, according to an embodiment of the present invention;

FIG. 2A-2B shows the storage container in an open state with the integrated mat pulled out of the container for

3

performing various activities using various objects contained inside the container, according to an embodiment of the present invention;

FIG. 3A-3B shows usability of the integrated mat that enables a user to roll back the objects into the storage container, according to an embodiment of the present invention;

FIG. 4 shows the storage container with a lid in an open state, and the objects and the integrated mat contained inside the container, according to an embodiment of the present invention;

FIG. 5 shows a cross sectional view of the storage container in an open state with the mat pulled out of the container, according to an embodiment of the present invention;

FIG. 6 shows an alternative embodiment of the present invention;

FIG. 7 shows yet another alternative embodiment of the present invention;

FIG. 8 shows the storage container of FIG. 7 in an open state with the integrated mat pulled out of the container for performing various activities using various objects contained inside the container;

FIG. 9 shows usability of the mat of FIG. 7 that would enable a user to roll or slide back the objects into the storage container; and

FIG. 10 shows use of the storage container with integrated mat of FIG. 7 by a child, according to an embodiment of the present invention.

#### DETAILED DESCRIPTION

Some embodiments, illustrating its features, will now be discussed in detail. The words “comprising,” “having,” “containing,” and “including,” and other forms thereof, are intended to be equivalent in meaning and be open ended in that an item or items following any one of these words is not meant to be an exhaustive listing of such item or items, or meant to be limited to only the listed item or items. It must also be noted that as used herein and in the appended claims, the singular forms “a,” “an,” and “the” include plural references unless the context clearly dictates otherwise. Although any methods, and systems similar or equivalent to those described herein can be used in the practice or testing of embodiments, the preferred methods, and systems are now described. The disclosed embodiments are merely exemplary.

References to “one embodiment,” “an embodiment,” “another embodiment,” “an example,” “another example,” “alternative embodiment,” “some embodiment,” “yet another embodiment,” and so on, indicate that the embodiment(s) or example(s) so described may include a particular feature, structure, characteristic, property, element, or limitation, but that not every embodiment or example necessarily includes that particular feature, structure, characteristic, property, element or limitation. Furthermore, repeated use of the phrase “in an embodiment” does not necessarily refer to the same embodiment. Unless stated otherwise, terms such as “first,” “second,” “third,” “fourth,” are used to arbitrarily distinguish between the elements such terms describe. Thus, these terms are not necessarily intended to indicate temporal or other prioritization of such elements.

In the context of present invention, the term “objects” is broadly used for any articles that can be housed in the container of the present invention, and is able to slide over the integrated mat. The examples include but not limited to toys, crafts material. Further, in the context of the present

4

invention, the term “container” is broadly used to denote means that can store some objects within it, such as baskets, backpacks, pouches etc. In the context of present invention, specifically claims, the wordings extremities and ends are interchangeably used just to arbitrarily distinguish between the elements. Use of such wordings should be regarded as equivalent.

The various features and embodiments of the storage container with an integrated mat **100** are better explained in conjunction with FIGS. 1-10.

Referring to FIGS.1-5, an embodiment of the present invention includes a storage container **100** with an integrated mat. The storage container **100** includes a receptacle **102**, a mat **104** integrally connected with the receptacle **102**, and a lid **106**. According to some other embodiment, the storage container **100** may be configured without the lid **106**.

The receptacle **102** includes a base **102b**, side walls **102c**, and an opening **102d** with a predefined circumference. The receptacle **102** may preferably be cylindrical or be in other suitable shapes. The receptacle **102** is adapted for holding one or more objects **108**. The one or more objects **101** preferably includes but not limited to toys, games, and crafts. According to the embodiment, the receptacle **102** may be provided with a pair of handles **102a** (although only one is seen visible) for providing assistance in lifting of the container **100**. The pair of handles **102a** are configured on the side walls **102c** of the receptacle **102**. According to an embodiment, the receptacle **102** may be rigid. According to some other embodiment, the receptacle **102** may be collapsible. According to some other embodiment, the receptacle **102** may be a backpack as shown in FIG. 6. According to some other embodiment, the receptacle **102** may in the form of a pouch as shown in FIG. 7.

According to the embodiment, the mat **104** is fixedly connected with the receptacle **102**. The mat **104** is flat preferably teardrop shaped and comprises of a top surface **104a**, and a bottom surface **104b**, a first end **104c**, a second end **104d**, a third end **104e**, and a fourth end **104f**. According to some embodiment, the mat **104** may be removably connected with the receptacle **102**. In some other embodiments, the mat **104** may be made rectangular, circular, oval, and the like or any other irregular shapes.

The mat **104** further includes a rim **103**. The rim **103** may be configured to project upward in a way to form a boundary wall along the perimeter of the mat **104** for retaining the objects **101** dispersed over the top surface **104a** of the mat **104**. This ensures, when the objects **101** are dispersed over the top surface **104a** of the mat **104** to perform various activities, the objects **101** don't move out of the boundary of the mat **104** easily. The rim **103** includes two ends, namely a first end **103c** and a second end **103d**. The rim **103** is disposed along the length of the second end **104d**, the third end **104e**, and the fourth end **104f**. The rim **103** further includes a first set of openings **103a**, and the second set of openings **103b**. According to the embodiment, the first set of openings **103a**, and the second set of openings **103b** may optionally be provided with grommets. In some other embodiments, any other stopper means that can act or serve the purpose of grommets can also be used. In one embodiment, the rim **103** may be separately sewn or attached along the length of the three ends **104d-104f** of the mat **104**. In another embodiment, the three ends **104d-104f** of the mat **104** may itself be folded and sewn to form the rim **103** all around the three ends **104d-104f** of the mat **104**.

According to the embodiment, the mat **104**, specifically the rim **103** includes a draw string **105** disposed therein. The draw string **105** includes two ends. The draw string **105** is

configured to run internally along the length of the rim 103. The two ends of the draw string 105 are fixedly attached to the receptacle 102 at a point where the two ends of the rim 103 attaches the receptacle 102. In some embodiment, the draw string 105 may be configured to run internally partially along the length of the rim 103. The draw string 105 further includes a first portion 105a, and a second portion 105b. The first portion 105a and the second portion 105b of the draw string 105 runs outside of the rim 103 for a distance at least equal to the distance between the first set of openings 103a, and the second set of openings 103b respectively at two sides of the mat 104. The first portion 105a, and the second portion 105b of the draw string 105 present outside the rim 103 are further provided with a first handle member 107a, and a second handle member 107b, respectively.

According to the embodiment, the draw string 105 further includes a first set of knots 105c, and a second set of knots 105d present in the vicinity of the first portion 105a, and the second portion 105b of the draw string 105 respectively within the rim 103 as shown in FIG. 5. The first set of knots 105c, and the second set of knots 105d restricts the length of the draw string 105 that can be pulled out of the respective two sets of openings 103a, 103b respectively. The restriction to the length of the draw string 105 that can be pulled out of the two sets of openings 103a, 103b facilitates in rolling back of the objects 101 into the storage container 100 or receptacle 102.

According to some other embodiment, the draw string 105 may not include any knots present along its length within the rim 103. According to yet other embodiment, the draw string 105 may include any other suitable means that can be substituted for and can serve as stopper just like the knots 105c, 105d.

According to the embodiment, the draw string 105 disposed within the rim 103 is configured to augment the shape of the mat 104 so the mat 104 can easily transform from the flat mat 104 to a chute (as shown in FIGS.3A-3B) so that the objects 101 can slide into the receptacle 102.

According to the embodiment, the mat 104 is fixedly connected to a portion along the circumference of the opening 102d of the receptacle 102 using the first end 104c along with the two ends 103c, 103d of the rim 103. According to yet other embodiment, the mat 104 may be removably connected to the portion along the circumference of the opening 102d of the receptacle 102 using the first end 104c along with the two ends 103c, 103d of the rim 103. The mechanisms known in the art preferably but not limited to a Zipper or a Velcro may be suitably configured at the first end 104c of the mat 104 and at the portion of receptacle's circumference to enable the removable connection between the mat 104 and the receptacle 102. The portion along the circumference of the opening 102d, where the mat 104 attaches may be 1/2 of the length of the circumference or 2/3 of the length of the circumference. In some embodiment, even the mat 104 may be attached along the full circumferential length of the opening 102d of the receptacle 102.

Referring to FIG. 6, an alternative embodiment of the present invention is shown. As shown, all the components described above with respect to the FIGS.1-5, specifically the mat 104 and associated components, parts thereof such as the draw string 105, the rim 103, and so on are likely implemented in a similar fashion in this alternative embodiment. The embodiment presented in FIG. 6, discloses an implementation of the described embodiment in the form of a backpack with an integrated mat 600. As seen, basically one can practice the above described invention in the FIGS.1-5 by suitably replacing the receptacle 102 with a

backpack 602 known in the art. The implementation shown in FIG. 6 will necessitate changes in terms of mechanism one needs to adapt for interconnecting the mat 104 with the backpack 602 due to the design changes of the receptacle which will be well understood by those skilled in the art.

In operation, when a user (preferably a kid) needs to have an access to the objects 101 contained inside the container 100, the user can open the lid 106 of the container 100. In the example presented, the lid 106 is hinged connected to the receptacle 102. Once the lid 106 is opened, the user can pull out the mat 104 foldably stored inside the receptacle 102 and deploy the mat 104 over the surface e.g. ground. Once the mat 104 is opened and deployed, the objects 101 are poured out of the receptacle 102 to occupy the top surface 104a of the mat 104 in order to perform desired activities. For example, if the users are kids, they can take out the objects 101 such as games, craft items, or toys for playing or for learning purpose.

Further, once the user has completed performing the intended activity with the objects 101 disposed over the top surface 104a of the mat 104, the user can with great ease, lift the two handle members 107a, 107b provided on two sides of the mat 104 which will augment the shape of the mat, changing it to a chute 104 to roll back the objects 101 into the receptacle 102 (as shown in FIG. 3B) and close the container 100 for external storage. The lifting of the two handle members 107a, 107b provided on the two sides of the mat 104 by the user facilitates the draw string 105 to get pulled out of the two sets of openings 103a, 103b to a certain length transforming the mat 104 to a chute (transforming the mat 104 into somewhat bowl shaped as shown in FIG. 3B) that causes the objects 101 (present over the mat's top surface 104a) to slide/roll in the direction of the receptacle 102 (as indicated by a set of arrows (referenced as 'S') in FIG. 3B).

Referring now to FIGS. 7-10, there is shown yet another alternative embodiment for a container 700 with an integrated mat. For the purpose of this invention, this embodiment will be referred to as a "table top" version. This table top version is preferably configured to be used by a user or a kid over a table or surface with lesser number of objects as shown in FIG. 10.

FIG. 7 in particular shows the container 700 in a closed state with the mat foldably stored inside the container 700. In the example, the container 700 is shown to be in the form of a drawstring closure pouch. The container 700 includes a receptacle portion 702 for holding various objects therein. The container 700 further includes a pouch handle 705 configured on outer surface/side walls 702c of the receptacle 702. The receptacle 702 also includes a base 702b, and an opening with a circumference 702d. The handle 705 is preferably configured using a strap foldably attached at one end to form a loop 706. This loop 706 may be useful in carrying of the container 700 or even the container 700 can be hung on an object such as a wall using the loop 706. The container 700 in the form of the drawstring closure pouch further includes a drawstring 703 configured around the neck region of the container/pouch 700 to help the user close or open the container 700. This drawstring closure mechanism is well known in the art and thus is not elaborated here for the sake of brevity or clarity of the invention.

FIG. 8 shows the container 700 in an open state with the integrated mat 704 pulled out of the container 700 for performing various activities using various objects (such as toys) contained inside the container 700. Like, the mat's 104 configuration described above with respect to FIGS.1-5, the table top version also comprises the mat 704. The mat 704

may be fixedly connected with the receptacle 702. The mat 704 is flat preferably teardrop shaped and comprises of a top surface 704a, and a bottom surface 704b, four ends (a first end 104c, a second end 104d, a third end 104e, and a fourth end 104f) similar to the mat 104 described above. According to some embodiment, the mat 704 may be removably connected with the receptacle 702. In some other embodiments, the mat 704 may be made rectangular, circular, oval and the like or any other irregular shape. Either fixedly or removably connected, the mat 704 is connected to a portion along the circumference of the opening of the receptacle 702. The mechanisms known in the art preferably but not limited to a Zipper or a Velcro may be suitably configured at the first end of the mat 704 and at the portion of receptacle's circumference to enable the removable connection between the mat 704 and the receptacle 702. The portion along the circumference of the opening, where the mat 704 attaches may be  $\frac{1}{2}$  of the length of the circumference or  $\frac{2}{3}$  of the length of the circumference.

The mat 704 further includes a rim 707 (similar to the rim 103 described above). The rim 707 includes two ends (similar to the ends 103c and 103d described above with respect to the rim 103). The rim 707 is disposed along the length of the second end 104d, the third end 104e, and the fourth end 104f similar to the rim 103 described above. The rim 707 may be configured to project upward in a way to form a boundary wall along the perimeter of the mat 704 for retaining the objects 101 dispersed over the top surface of the mat 704. This ensures when the objects 101 are dispersed over the top surface of the mat 704 to perform various activities, the objects don't move out of the boundary of the mat 704 easily. Unlike the rim 103, the rim 707 includes one set of openings (not shown). According to the embodiment, the set of openings may or may not be provided with grommets. In some other embodiments, any other stopper means that can act or serve the purpose of grommets can also be used. Also, in some other embodiments, any other stopper means that can act or serve the purpose of grommets can also be used. In one embodiment, the rim 707 may be separately sewn or attached along the length of the three ends 104d-104f of the mat 704. In another embodiment, the three ends 104d-104f of the mat 704 may itself be folded and sewn to form the rim 707 all around the three ends 104d-104f of the mat 704.

According to the embodiment, the mat 704, specifically the rim 707 includes a draw string 708 disposed therein. The draw string 708 includes two ends. The draw string 708 is configured to run internally (or within interior) partially along the length of the rim 707. The two ends of the draw string 708 are fixedly attached at a point within the rim 707. In an example, the two ends 708a, and 708b of the draw string 708 are preferably attached within the rim 704 about a half way along the length of the rim 704. The draw string 708 further includes a portion 708c that runs outside of the rim 707 for a distance at least equal to the distance between the openings present at the third end 104e of the mat 704. The portion 708c of the draw string 708 present outside the rim 707 may further be provided with a handle or a pull tab 708d. The user/kid using the container with the integrated mat 700 can hold this pull tab 708d, and the handle 705 together using his/her two hands and apply a pull force in opposite direction (in the direction of dotted arrows) to draw close the mat 704 as shown represented in FIG. 9. When the user applies the pull force in the opposite direction using the handle 705 and the pull tab 708d, the mat 704 transforms to a chute (as shown in FIG. 9) so that the objects 101

contained over the top surface 704a of the mat 704 can slide or roll back into the receptacle 702.

It should be noted that, the containers 100, or 600, or 700, the mats 104, or 704 and any associated components, parts thereof described above in the FIGS.1-11 with respect to various embodiments may be made of any suitable material known in the art, and be made in different shapes and sizes that may make the presented invention realization in real scenario. It is also possible that different parts or components of the invention may be made of different materials and thus use of material should not be considered as any limitation to the implementation of the present invention.

The preceding description has been presented with reference to various embodiments. Persons skilled in the art and technology to which this application pertains will appreciate that alterations and changes in the described structures and methods of operation can be practiced without meaningfully departing from the principle, spirit and scope of the present invention.

What is claimed is:

1. A storage container with an integrated mat (100), comprising:

a receptacle (102) adapted for holding one or more objects (101), wherein the receptacle (102) comprises of a base (102b), side walls (102c), and an opening (102d) with a predefined circumference;

an integrated mat (104) comprising:

a top surface (104a), a bottom surface (104b), a first end (104c), a second end (104d), a third end (104e), and a fourth end (104f);

a rim (103) having two ends (103c, 103d), wherein the rim (103) is disposed along the length of the second end (104d), the third end (104e), and the fourth end (104f) of the integrated mat (104);

a draw string (105) having two extremities, wherein the draw string (105) is configured to run internally along the length of the rim (103); and

wherein, the integrated mat (104) is connected to a portion of and along the predefined circumference of the opening (102d) of the receptacle (102) using the first end (104c) along with the two ends (103c, 103d) of the rim (103).

2. The storage container (100) of claim 1, wherein the one or more objects (101) comprises at least one of toys, games, and crafts.

3. The storage container (100) of claim 1, wherein the two extremities of the draw string (105) fixedly attaches to the receptacle (102) at a point where the two ends (103c, 103d) of the rim (103) attaches the receptacle (102).

4. The storage container (100) of claim 1, wherein the rim (103) further comprises of a first set of openings (103a), and the second set of openings (103b) provided with grommets.

5. The storage container (100) of claim 1, wherein the draw string (105) comprises a first portion (105a), and a second portion (105b) that runs outside of the rim (103) for a distance at least equal to the distance between the first set of openings (103a), and the second set of openings (103b) respectively at two sides of the integrated mat (104).

6. The storage container (100) of claim 5, wherein the first portion (105a), and the second portion (105b) of the draw string (105) present outside the rim (103) at the two sides of the integrated mat (104) are provided with a first handle member (107a), and a second handle (107b), respectively.

7. The storage container (100) of claim 1, wherein the draw string (105) further comprises a first set of knots (105c), and a second set of knots (105d) present in the vicinity of the first portion (105a), and the second portion

(105b) of the draw string (105) respectively within the rim (103) to restrict the length of the draw string (105) that can be pulled out of the first set of openings (103a), and the second set of openings (103b) respectively.

8. The storage container (100) of claim 7, wherein the restriction to the length of the draw string (105) that can be pulled out of the first set of openings (103a), and the second set of openings (103b) facilitates in rolling back of the one or more objects (101) into the receptacle (102) without disturbing the integrity of the container (100).

9. The storage container (100) of claim 1, wherein the rim (103) is configured to project upward in the form of a boundary wall along perimeter of the mat (104) for retaining the one or more objects (101) dispersed over the top surface (104a) of the integrated mat (104) to ensure the one or more objects (101) don't move out of the integrated mat (104), while a user perform different activities over the integrated mat (104) using the one or more objects (101).

10. The storage container (100) of claim 1 further comprising a lid (106) configured to be used by the user to open or close the container (100).

11. The storage container (100) of claim 1, wherein the receptacle (102) is configured in the form of at least a rigid basket, a collapsible basket, a backpack, and a drawstring closure pouch.

12. The storage container (100) of claim 1, wherein the receptacle 102 is provided with a pair of handles (102a) configured on the side walls (102c).

13. The storage container (100) of claim 1, wherein the portion along the predefined circumference of the opening (102d) of the receptacle (102), where the integrated mat (104) attaches the receptacle (102) is at least one 1/2 of the length of the circumference or 2/3 of the length of the circumference, or full length of the circumference.

14. A storage container with an integrated mat (700) configured as a pouch, comprising:

a receptacle (702) adapted for holding one or more objects (101), wherein the receptacle (102) comprises of a base (702b), side walls (702c), and an opening (702d) with a predefined circumference;

a handle (705) configured outside of the side walls (702c) of the receptacle (702);

an integrated mat (104) comprising:

a top surface (704a), a bottom surface (704b), a first end (104c), a second end (104d), a third end(104e), and a fourth end (104f);

a rim (707) having two ends (103c, 103d), wherein the rim (707) is disposed along the length of the second end (104d), the third end(104e), and the fourth end (104f) of the integrated mat (704);

a draw string (708) having two extremities, wherein the draw string (708) is configured to run partially within interior and along the length of the rim (707); and

wherein, the integrated mat (704) is connected to a portion of and along the predefined circumference of the opening (702d) of the receptacle (702) using the first end (104c) along with the two ends (103c, 103d) of the rim (707).

15. The storage container (700) of claim 14, wherein the rim (707) further comprises a set of openings.

16. The storage container (700) of claim 14, wherein the draw string (708) comprises a portion (708c) that runs outside of the rim (707) for a distance at least equal to the distance between the set of openings present at the third end (104e) of the mat (704).

17. The storage container (700) of claim 16, wherein the portion (708c) of the draw string (708) that runs outside the rim (707) is provided with a pull tab (708d).

18. The storage container (700) of claim 17, wherein the knob (708d) is used by a user along with the handle (705) configured on the side walls (702c) of the receptacle (702) to draw close the integrated mat (704) in order to facilitate rolling back of the one or more objects (101) into the receptacle (702).

19. The storage container (700) of claim 14, wherein the rim (707) is configured in the form of a boundary wall to project upward along perimeter of the mat (704) for retaining the one or more objects (101) dispersed over the top surface (704a) of the integrated mat (704) to ensure the one or more objects (101) don't move out of the integrated mat (704), while a user perform different activities over the integrated mat (704) using the one or more objects (101).

20. The storage container (700) of claim 14, wherein the portion along the predefined circumference of the opening (702d) of the receptacle (702), where the integrated mat (704) attaches the receptacle (702) is at least one 1/2 of the length of the circumference or 2/3 of the length of the circumference, or the full length of the circumference.

\* \* \* \* \*

# **EXHIBIT 3**

Generated on: This page was generated by TSDR on 2021-10-13 09:27:57 EDT

Mark: SLIDEAWAY

# SLIDEAWAY

US Serial Number: 88479271

Application Filing Date: Jun. 19, 2019

US Registration Number: 5994698

Registration Date: Feb. 25, 2020

Filed as TEAS RF: Yes

Currently TEAS RF: Yes

Register: Principal

Mark Type: Trademark

TM5 Common Status Descriptor:



LIVE/REGISTRATION/Issued and Active

The trademark application has been registered with the Office.

Status: Registered. The registration date is used to determine when post-registration maintenance documents are due.

Status Date: Feb. 25, 2020

Publication Date: Dec. 10, 2019

## Mark Information

Mark Literal Elements: SLIDEAWAY

Standard Character Claim: Yes. The mark consists of standard characters without claim to any particular font style, size, or color.

Mark Drawing Type: 4 - STANDARD CHARACTER MARK

## Goods and Services

### Note:

The following symbols indicate that the registrant/owner has amended the goods/services:

- Brackets [...] indicate deleted goods/services;
- Double parenthesis (..) identify any goods/services not claimed in a Section 15 affidavit of incontestability; and
- Asterisks \*..\* identify additional (new) wording in the goods/services.

For: Fabric sided toy storage container in the nature of a toy box or toy chest having an integrated play mat

International Class(es): 020 - Primary Class

U.S Class(es): 002, 013, 022, 025, 032, 050

Class Status: ACTIVE

Basis: 1(a)

First Use: May 07, 2019

Use in Commerce: May 07, 2019

## Basis Information (Case Level)

Filed Use: Yes

Currently Use: Yes

Filed ITU: No

Currently ITU: No

Filed 44D: No

Currently 44E: No

Filed 44E: No

Currently 66A: No

Filed 66A: No

Currently No Basis: No

Filed No Basis: No

## Current Owner(s) Information

Owner Name: BROADWAY PINE BRANDS LLC

Owner Address: 113 CHERRY ST  
PMB 89249  
SEATTLE, WASHINGTON UNITED STATES 98104

Legal Entity Type: LIMITED LIABILITY COMPANY

State or Country Where Organized: DELAWARE

## Attorney/Correspondence Information

Attorney of Record - None

Correspondent

Correspondent Name/Address: ADAM HINKLE  
1804 ENGLISH PRAIRIE RD  
SPRING GROVE, ILLINOIS UNITED STATES 60081  
Phone: 719-459-3957

Domestic Representative - Not Found

## Prosecution History

Date	Description	Proceeding Number
Apr. 22, 2021	AUTOMATIC UPDATE OF ASSIGNMENT OF OWNERSHIP	
Feb. 25, 2020	REGISTERED-PRINCIPAL REGISTER	
Dec. 10, 2019	OFFICIAL GAZETTE PUBLICATION CONFIRMATION E-MAILED	
Dec. 10, 2019	PUBLISHED FOR OPPOSITION	
Nov. 20, 2019	NOTIFICATION OF NOTICE OF PUBLICATION E-MAILED	
Nov. 04, 2019	APPROVED FOR PUB - PRINCIPAL REGISTER	
Oct. 04, 2019	TEAS/EMAIL CORRESPONDENCE ENTERED	69712
Oct. 04, 2019	CORRESPONDENCE RECEIVED IN LAW OFFICE	69712
Sep. 30, 2019	ASSIGNED TO LIE	69712
Sep. 20, 2019	TEAS RESPONSE TO OFFICE ACTION RECEIVED	
Sep. 12, 2019	NOTIFICATION OF EXAMINER'S AMENDMENT/PRIORITY ACTION E-MAILED	6326
Sep. 12, 2019	EXAMINER'S AMENDMENT/PRIORITY ACTION E-MAILED	6326
Sep. 12, 2019	COMBINED EXAMINER'S AMENDMENT/PRIORITY ACTION AUTOMATIC ENTRY	78480
Sep. 12, 2019	EXAMINERS AMENDMENT AND/OR PRIORITY ACTION - COMPLETED	78480
Sep. 10, 2019	ASSIGNED TO EXAMINER	78480
Jun. 29, 2019	NEW APPLICATION OFFICE SUPPLIED DATA ENTERED IN TRAM	
Jun. 22, 2019	NEW APPLICATION ENTERED IN TRAM	

## TM Staff and Location Information

TM Staff Information - None

File Location

Current Location: PUBLICATION AND ISSUE SECTION

Date in Location: Feb. 25, 2020

## Assignment Abstract Of Title Information

### Summary

Total Assignments: 1

Registrant: Hinkle, Adam

### Assignment 1 of 1

Conveyance: ASSIGNS THE ENTIRE INTEREST

Reel/Frame: [7253/0543](#)

Pages: 6

Date Recorded: Apr. 13, 2021

Supporting Documents: [assignment-tm-7253-0543.pdf](#)

### Assignor

Name: [HINKLE, ADAM](#)

Execution Date: Apr. 08, 2021

Legal Entity Type: INDIVIDUAL

Citizenship: No Citizenship Found

**Assignee**

**Name:** [BROADWAY PINE BRANDS LLC](#)

**Legal Entity Type:** LIMITED LIABILITY COMPANY

**State or Country Where Organized:** DELAWARE

**Address:** 113 CHERRY ST  
PMB 89249  
SEATTLE, WASHINGTON 98104

**Correspondent**

**Correspondent Name:** JOHN ERVIN

**Correspondent Address:** 100 S ASHLEY DR STE 620  
TAMPA, FL 33602

**Domestic Representative - Not Found**

# United States of America

United States Patent and Trademark Office

## SLIDEAWAY

**Reg. No. 5,994,698**

**Registered Feb. 25, 2020**

**Int. Cl.: 20**

**Trademark**

**Principal Register**

Hinkle, Adam (UNITED STATES INDIVIDUAL), DBA Creative QT  
1804 English Prairie Rd  
Spring Grove, ILLINOIS 60081

CLASS 20: Fabric sided toy storage container in the nature of a toy box or toy chest having an integrated play mat

FIRST USE 5-7-2019; IN COMMERCE 5-7-2019

THE MARK CONSISTS OF STANDARD CHARACTERS WITHOUT CLAIM TO ANY PARTICULAR FONT STYLE, SIZE OR COLOR

SER. NO. 88-479,271, FILED 06-19-2019

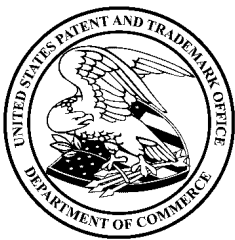

*Andrei Iancu*

Director of the United States  
Patent and Trademark Office



**REQUIREMENTS TO MAINTAIN YOUR FEDERAL TRADEMARK REGISTRATION**

**WARNING: YOUR REGISTRATION WILL BE CANCELLED IF YOU DO NOT FILE THE DOCUMENTS BELOW DURING THE SPECIFIED TIME PERIODS.**

**Requirements in the First Ten Years\***

**What and When to File:**

- **First Filing Deadline:** You must file a Declaration of Use (or Excusable Nonuse) between the 5th and 6th years after the registration date. See 15 U.S.C. §§1058, 1141k. If the declaration is accepted, the registration will continue in force for the remainder of the ten-year period, calculated from the registration date, unless cancelled by an order of the Commissioner for Trademarks or a federal court.
- **Second Filing Deadline:** You must file a Declaration of Use (or Excusable Nonuse) and an Application for Renewal between the 9th and 10th years after the registration date.\* See 15 U.S.C. §1059.

**Requirements in Successive Ten-Year Periods\***

**What and When to File:**

- You must file a Declaration of Use (or Excusable Nonuse) and an Application for Renewal between every 9th and 10th-year period, calculated from the registration date.\*

**Grace Period Filings\***

The above documents will be accepted as timely if filed within six months after the deadlines listed above with the payment of an additional fee.

**\*ATTENTION MADRID PROTOCOL REGISTRANTS:** The holder of an international registration with an extension of protection to the United States under the Madrid Protocol must timely file the Declarations of Use (or Excusable Nonuse) referenced above directly with the United States Patent and Trademark Office (USPTO). The time periods for filing are based on the U.S. registration date (not the international registration date). The deadlines and grace periods for the Declarations of Use (or Excusable Nonuse) are identical to those for nationally issued registrations. See 15 U.S.C. §§1058, 1141k. However, owners of international registrations do not file renewal applications at the USPTO. Instead, the holder must file a renewal of the underlying international registration at the International Bureau of the World Intellectual Property Organization, under Article 7 of the Madrid Protocol, before the expiration of each ten-year term of protection, calculated from the date of the international registration. See 15 U.S.C. §1141j. For more information and renewal forms for the international registration, see <http://www.wipo.int/madrid/en/>.

**NOTE: Fees and requirements for maintaining registrations are subject to change. Please check the USPTO website for further information. With the exception of renewal applications for registered extensions of protection, you can file the registration maintenance documents referenced above online at <http://www.uspto.gov>.**

**NOTE: A courtesy e-mail reminder of USPTO maintenance filing deadlines will be sent to trademark owners/holders who authorize e-mail communication and maintain a current e-mail address with the USPTO. To ensure that e-mail is authorized and your address is current, please use the Trademark Electronic Application System (TEAS) Correspondence Address and Change of Owner Address Forms available at <http://www.uspto.gov>.**

# **EXHIBIT 4**

**Text of Claim 1**

**Patented Product**

- a) A storage container with an integrated mat (100), comprising:
- b) a receptacle (102) adapted for holding one or more objects (101), wherein the receptacle (102) comprises of a base (102 b), side walls (102 c), and an opening (102 d) with a predefined circumference;
- c) an integrated mat (104) comprising:
  - a top surface (104 a), a bottom surface (104 b), a first end (104 c), a second end (104 d), a third end (104 e), and a fourth end (104 f);
  - a rim (103) having two ends (103 c, 103 d), wherein the rim (103) is disposed along the length of the second end (104 d), the third end (104 e), and the fourth end (104 f) of the integrated mat (104);
- d) a draw string (105) having two extremities, wherein the draw string (105) is configured to run internally along the length of the rim (103); and
- e) wherein, the integrated mat (104) is connected to a portion of and along the predefined circumference of the opening (102 d) of the receptacle (102) using the first end (104 c) along with the two ends (103 c, 103 d) of the rim (103).

*This is the preamble.*

