

IN THE UNITED STATES DISTRICT COURT  
FOR THE WESTERN DISTRICT OF PENNSYLVANIA

AIRIGAN SOLUTIONS, LLC,

Plaintiff,

v.

MORNING CHEF, BEI JING ZHI FU KE JI,  
JZQBXXYL, KUNMINGWUHUASS,  
LALAXIAOHUMAoyI, LINLINGLIU,  
RONGXIANG TRADING, SONGSIQING  
TRADING, XINYAHANZHUANGSHI,  
XULIZHIXINGKEJI, ZHIJIANSHANGMAO,  
YIWU BAOWO TRADING CO., LTD.,  
YUHUAN AOBO PLASTIC INDUSTRY CO.,  
LTD., ALI-YY120 STORE, ALI-ZYAG-1  
STORE, ALI-ZYAR-1 STORE, CHANSUNRUN  
YAYA STORE, GOOD SHAPE-KEEP STORE,  
HOEADEN WARM COZY HOME STORE,  
IMAGINATION321 STORE, MAGIC666  
STORE, MY CHILDHOOD WORLD STORE,  
SAVOR STORE, SHOP1102675024 STORE,  
SHOP1103257141 STORE, SHOP1103580739  
STORE, SHOP1103620766 STORE,  
SHOP1103652096 STORE, SHOP1103847354  
STORE, SUMORY STORE, YCYC0124 STORE,  
IMAGINARY VISIONS ECOMMERCE LLC,  
OSCARLETT COMPANY LLC, OL16 LLC,  
MARKETING FOREVER VISUET LLC, and  
DQSTORE,

Defendants.

Civil Action No.

**FILED UNDER SEAL**

**COMPLAINT FOR DAMAGES AND INJUNCTIVE RELIEF**

Plaintiff Airigan Solutions, LLC (“Airigan” or “Plaintiff”) hereby sues Defendants, the Individuals, Partnerships, and Unincorporated Associations identified in the Caption, which are set forth in **Schedule “A”** hereto (collectively “Defendants”). All of the Defendants are (i)

promoting, selling, offering for sale and distributing goods bearing and/or using counterfeits and/or confusingly similar imitations of Plaintiff’s registered copyrighted works, and (ii) promoting, selling, offering for sale and distributing goods infringing Plaintiff’s patent (collectively, the “Infringing Products”), thus unfairly competing within this district through at least one of the Amazon.com, eBay.com, Alibaba.com, AliExpress.com, Temu.com, TikTok, Walmart.com, or Wish.com online marketplaces operating under the seller identities as set forth on **Schedule “A”** hereto (the “Seller IDs”). In support of its claims, Plaintiff alleges as follows:

### **INTRODUCTION**

1. Airigan Solutions, LLC, was founded in 2015 and is in the business of producing, marketing and selling the patented NEGG<sup>®</sup> brand egg peeler, which was launched in 2015.

2. The genuine NEGG<sup>®</sup> brand egg peeler (Fig. 1, below) is designed so that by placing a standard chicken egg inside with a capful of water, tightly fastening the opposing lids, and shaking the egg peeler, the shell is punctured and cracked so that it simply peels off in one continuous motion (“Plaintiff’s Product”) (Fig. 2, below):







Fig. 1



Fig. 2

The distinctive photograph of the NEGG<sup>®</sup> brand egg peeler found on all the packaging and on-line sales materials was posed with parsley leaves underneath the right facing side of the egg peeler.

3. Defendants' sale, distribution, and advertising of their goods are highly likely to cause consumers to believe that Defendants are offering genuine versions of Plaintiff's Product when in fact they are not. To illustrate, below are several examples which vividly show that the way Defendants' goods are marketed is designed to confuse and mislead consumers into believing that they are purchasing Plaintiff's Product or that the Defendants' goods are otherwise approved by or sourced from Plaintiff:

<p><b><u>Plaintiff's Patented Egg Peeler</u></b></p>  A red egg peeler with a clear plastic body and a red base. It contains a brown egg. The peeler has several small holes on the sides for peeling. A small green leaf is visible at the bottom right.	<p><b><u>Defendant Morning Chef Listing</u></b></p>  A yellow egg peeler with a clear plastic body and a yellow base. It is empty. The peeler has several small holes on the sides for peeling.
<p><b><u>Plaintiff's Patented Egg Peeler</u></b></p>  A red egg peeler with a clear plastic body and a red base. It contains a brown egg. The peeler has several small holes on the sides for peeling. A small green leaf is visible at the bottom right.	<p><b><u>Defendant linlingliu Listing</u></b></p>  A red egg peeler with a clear plastic body and a red base. It contains a brown egg. The peeler has several small holes on the sides for peeling. A small green leaf is visible at the bottom right.

**Plaintiff's Copyrighted Product Image**



**Defendant Yuhan Aobo Plastic Industry Col., Ltd. Store Listing**



**Plaintiff's Patented Egg Peeler**



**Defendant DQstore Listing**



4. Defendants' goods are often cheaply produced and substantially inferior to Plaintiff's genuine products. Plaintiff's genuine products are made from food grade plastic; it is unknown what Defendants' goods are made from. As poorly manufactured products, Defendants' goods create risks since they are intended for use with food, namely hard-boiled eggs.

5. Defendants' goods threaten to destroy the reputation of high quality that Plaintiff's Products have earned. Defendants' goods create risks as they do not appear to be of the same

quality as the genuine goods. Plaintiff has received numerous complaints about Defendants' goods.

6. Defendants' actions have resulted in actual confusion in the marketplace between Defendants' goods and genuine Plaintiff's Products. Numerous purchasers of Defendants' goods have written online reviews to complain about the quality of the Defendants' goods believing same to be genuine versions of Plaintiff's Product.

7. Plaintiff is also the owner of various published photographs, videos, artwork, creative text and product instructions appearing on its web site <https://neggmaker.com/>. Screenshots of Plaintiff's Website and Amazon Store are attached to the Complaint as "**Exhibit 4**" ("Plaintiff's Work"). The combined distinct features of Plaintiff's Product and Plaintiff's Mark function as a trade dress so that consumers are certain that Plaintiff is the source of the Negg® brand egg peeler.

8. Plaintiff is the owner of source identifying trademarks, including NEGG® (Reg. No. 5,142,630 attached as **Exhibit 1**) and trade dress shown in **Exhibit 2** that Plaintiff uses to distinguish its unique product ("Plaintiff's Marks"). Plaintiff owns the overall combination and arrangement of all non-functional design elements of Plaintiff's product and packaging, including its product insert, which are inherently distinctive and/or have acquired secondary meaning in the mind of the purchasing public. The Plaintiff's packaging is the subject of U.S. Copyright Registration No. U.S. Copyright VA0002237199, a copy of which is included in Exhibit 2. Additionally, Plaintiff owns a United States patent for its unique NEGG® product, including U.S. Patent No. 9,968,211 for PERSONAL EGG PEELER (attached as **Exhibit 3**).

9. Plaintiff's Work, Marks, and Patent make it unlawful for competitors to infringe Plaintiff's rights.

### **JURISDICTION AND VENUE**

10. This is an action for patent infringement pursuant to 35 U.S.C. § 271, federal copyright infringement; federal unfair competition; and common law unfair competition. Accordingly, this Court has subject matter jurisdiction over this action pursuant to 15 U.S.C. §§ 1114, 1116, 1125(a), and 1125(d); and patent infringement pursuant to 35 U.S.C. § 271 and The All Writs Act, 28 U.S.C. § 1651(a). Accordingly, this Court has subject matter jurisdiction over this action pursuant to 15 U.S.C. § 1121 and 28 U.S.C. §§ 1331 and 1338. This Court has supplemental jurisdiction pursuant to 28 U.S.C. § 1367 over Plaintiff's state law claims because those claims are so related to the federal claims that they form part of the same case or controversy.

11. This Court may exercise personal jurisdiction over a non-resident of the State in which the Court sits to the extent authorized by the state's laws. Fed. R. Civ. P. 4(e). Pennsylvania authorizes personal jurisdiction over the Defendant pursuant to 42 Pa. Cons. Stat. § 5322 (a) which provides in pertinent part: "A tribunal of this Commonwealth may exercise personal jurisdiction over a person ... as to a cause of action or other matter arising from such person: (1) Transacting any business in this Commonwealth. Without excluding other acts which may constitute transacting business for the purpose of this paragraph: (ii) The doing of a single act in this Commonwealth for the purpose of thereby realizing pecuniary benefit ... (3) Causing harm or tortious injury by an act or omission in this Commonwealth. (4) Causing harm or tortious injury by an act or omission outside this Commonwealth ... (10) Committing any violation within the jurisdiction of the Commonwealth of any statute, home rule charter, local

ordinance or resolution, or rule or regulation promulgated thereunder by any government unit or of any order of court or other government unit.” In the alternative, Federal Rule of Civil Procedure 4(k) confers personal jurisdiction over the Defendant because, upon information and belief, Defendants regularly conduct, transact and/or solicit business in Pennsylvania and in this judicial district, and/or derive substantial revenue from their business transactions in Pennsylvania and in this judicial district and/or otherwise avail themselves of the privileges and protections of the laws of the Commonwealth of Pennsylvania such that this Court's assertion of jurisdiction over Defendants does not offend traditional notions of fair play and due process, and/or Defendants' illegal counterfeiting and infringing actions caused injury to Plaintiff in Pennsylvania and in this judicial district such that Defendants should reasonably expect such actions to have consequences in Pennsylvania and in this judicial district, for example:

a. Upon information and belief, Defendants were and/or are systematically directing and/or targeting their business activities at consumers in the United States, including Pennsylvania, through on-line platforms with Merchant Storefronts (as defined *infra*), via at least one of the Amazon.com, eBay.com, Alibaba.com, AliExpress.com, Walmart.com, or Wish.com online marketplaces, under the Seller IDs, as well as any and all as yet undiscovered accounts with Merchant Storefronts held by or associated with Defendants, their respective officers, employees, agents, servants and all persons in active concert or participation with any of them (“User Accounts”), through which consumers in the United States, including Pennsylvania, can view the one or more of Defendants' Merchant Storefronts that each Defendant operates, uses to communicate with Defendants regarding their listings for Counterfeit Products and to place orders for, receive invoices for and purchase Counterfeit Products for delivery in the U.S., including

Pennsylvania, as a means for establishing regular business with the U.S., including Pennsylvania.

b. Upon information and belief, certain Defendants are sophisticated sellers, each operating one or more commercial businesses using their respective User Accounts through which Defendants, their respective officers, employees, agents, servants and all persons in active concert of participation with any of them, operate storefronts to manufacture, import, export, advertise, market, promote, distribute, offer for sale and/or otherwise deal in products, including the Counterfeit Products, which are held by or associated with Defendants, their respective officers, employees, agents, servants and all persons in active concert or participation with any of them (“Merchant Storefront(s)”) in wholesale quantities at significantly below-market prices to consumers worldwide, including to those in the U.S., and specifically Pennsylvania.

c. Upon information and belief, Defendants’ Merchant Storefronts reflect multiple sales to consumers all over the world, including repeat sales to consumers in the U.S. and into this judicial district.

d. Upon information and belief, all Defendants accept payment in U.S. Dollars and offer shipping to the U.S., including to Pennsylvania and specifically to the Pennsylvania Address (as defined *infra*).

e. Upon information and belief, Defendants have transacted business with consumers located in the U.S., including Pennsylvania, for the sale and shipment of Counterfeit Products (as defined *infra*).

f. Upon information and belief, Defendants are employing and benefiting from substantially similar paid advertising and marketing and advertising strategies in order to make their Merchant Storefronts selling illegal goods appear more relevant and attractive to search result software across an array of search words, including but not limited to “NEGG”, “EGG PEELER”, and “EGG CRACKER”, and “BOILED EGG PEELER”. By their actions, Defendants are causing concurrent and indivisible harm to Plaintiff and the consuming public by (i) depriving Plaintiff of its right to fairly compete for space within the various on-line marketplace search results and reducing the visibility of the Plaintiff’s Product on various on-line marketplaces and/or diluting and driving down the retail market price for Plaintiff’s Product; (ii) causing an overall degradation of the value of the goodwill associated with Plaintiff’s marks and goods; and (iii) increasing Plaintiff’s overall cost to market its goods and educate consumers about brands.

g. Upon information and belief, Defendants have cooperated, communicated their plans with one another, shared information, and coordinated their efforts, all in order to create an illegal marketplace operating in parallel to the legitimate marketplace of Plaintiff’s and the legally authorized resellers of Plaintiff’s genuine goods.

h. Upon information and belief, Defendants are concurrently targeting their counterfeiting and infringing activities toward consumers and causing harm in Allegheny County, Pennsylvania.

i. Upon information and belief, Defendants likely reside and/or operate in or, though not foreign, operate out of or from foreign jurisdictions with lax trademark and patent enforcement systems and are cooperating by creating an illegal stream of infringing and counterfeit goods.

j. Upon information and belief, Defendants are aware of Plaintiff's Product, and are aware that their illegal infringing actions alleged herein are likely to cause injury to Plaintiff in the United States, in Pennsylvania and in this judicial district specifically, as Plaintiff conducts substantial business in Pennsylvania.

k. Plaintiff is suffering irreparable and indivisible injury and suffered substantial damages as a result of Defendants' unauthorized and wrongful sale of counterfeit and infringing goods.

3. Venue is proper, *inter alia*, pursuant to 28 U.S.C. § 1391 and 28 U.S.C. § 1400(b) because, for example:

a. Upon information and belief, Defendants conduct, transact, and/or solicit business in this judicial district.

b. Upon information and belief, Defendants or their agent(s) may be found in this district because personal jurisdiction is proper in this district.

c. Upon information and belief, this is a judicial district in which a substantial part of the events or omissions giving rise to the infringement claims occurred, or a substantial part of the property that is the subject of the action is situated.

d. Defendants not resident in the United States may be sued in this judicial district because personal jurisdiction is proper in this district.

### **THE PLAINTIFF**

12. Plaintiff is a limited liability company organized and existing under the laws of the State of Connecticut, having its principal place of business at 107 John Street, Suite 1-C, Southport, Connecticut 06890.

13. Plaintiff sells a unique and revolutionary patented product under the federally registered trademark NEGG<sup>®</sup> that quickly and easily peels hard boiled eggs.

14. Plaintiff has spent substantial time, money and effort in building up and developing consumer recognition, awareness and goodwill in its NEGG<sup>®</sup> mark and NEGG<sup>®</sup> product.

15. The success of the NEGG<sup>®</sup> product is due in part to Plaintiff's marketing and promotional efforts. These efforts include advertising and promotion through television, retailer websites and other internet-based advertising, print, participation in trade shows, among other efforts, including Pennsylvania.

16. Plaintiff's NEGG<sup>®</sup> product has been featured on television ("The Today Show," Home Shopping Network), newspapers (*New York Times*, *USA Today*) and numerous videos on YouTube, Facebook and other social media sites. Numerous videos featuring Plaintiff's NEGG<sup>®</sup> product have been collectively viewed hundreds of thousands of times, if not millions of times.

17. Plaintiff's NEGG<sup>®</sup> product is proudly manufactured in the United States using the highest quality materials and processes.

18. Plaintiff owns trademark rights, trade dress, and patent rights regarding its NEGG<sup>®</sup> product.

### **THE DEFENDANTS**

19. The Defendants are individuals and/or business entities of unknown makeup, each of whom, upon information and belief, either reside or operate in foreign jurisdictions, or (though

not foreign)<sup>1</sup> redistribute products from the same or similar sources in those locations. Defendants have the capacity to be sued pursuant to Federal Rule of Civil Procedure 17(b). Defendants target their business activities toward consumers throughout the United States, including within this district, and conduct pervasive business through the operation of at least one of the Internet based online marketplaces Amazon.com, eBay.com, Alibaba.com, Temu, TikTok, AliExpress.com, Walmart.com and Wish.com under the Seller IDs.

20. Defendants use aliases in conjunction with the operation of their businesses, including but not limited to those as set forth in **Schedule “A”** hereto.

21. Defendants are the past and present controlling forces behind the sale of products bearing and/or using infringements of at least one of the Plaintiff’s Patent and Work, and/or a substantially similar copy of Plaintiff’s Work as described herein using at least the Seller IDs.

22. Upon information and belief, Defendants directly engage in unfair competition with Plaintiff and its authorized sellers by advertising, offering for sale and selling goods bearing and/or using counterfeits and infringements of Plaintiff’s Work and Patent to consumers within the United States and this district through several fully interactive, commercial Internet websites and Internet based e-commerce stores operating under, at least, the storefronts, the Seller IDs, and any additional domain names, websites and corresponding website URLs or seller identifications and store URL aliases not yet known to Plaintiff. Defendants have purposefully

---

<sup>1</sup> Prior to filing this lawsuit, Plaintiffs viewed a public seller profile that is published by certain Defendant’s storefronts that purports to identify the name and address of the Defendant. Solely based upon their representation on their storefronts, the following defendants have identified themselves as US-based and are not at this time alleged to be foreign sellers: Morning Chef, Imaginary Visions Ecommerce LLC, OSCARLETT COMPANY LLC, OL16 LLC, and MARKETING FOREVER VISUET LLC.

directed some portion of their illegal activities towards consumers in the Commonwealth of Pennsylvania through the advertisement, offer to sell, sale, and/or shipment of counterfeit and infringing goods into the Commonwealth.

23. Defendants have registered, established or purchased, and maintained the online marketplace website storefronts and Seller IDs. Upon information and belief, Defendants have engaged in fraudulent conduct with respect to the registration of the storefronts and Seller IDs by providing false and/or misleading information to the Internet based e-commerce platforms where they offer for sale and/or sell, during the registration or maintenance process related to their respective Seller ID. Upon information and belief, Defendants have anonymously registered and maintained some of the Seller IDs for the sole purpose of engaging in illegal infringing activities.

24. Upon information and belief, Defendants will continue to register or acquire new seller identification aliases for the purpose of selling and offering for sale goods bearing and/or advertised using confusingly similar imitations of Plaintiff's Work and infringing Plaintiff's patent unless preliminarily and permanently enjoined.

25. Defendants' Internet-based businesses amount to nothing more than illegal operations established and operated in order to infringe the intellectual property rights of Plaintiff.

26. Defendants' business names, i.e., the Seller IDs, associated payment accounts, and any other alias seller identification names used in connection with the sale of infringing goods bearing and/or using Plaintiff's Work and Patent are essential components of Defendants' online activities and are the means by which Defendants further their infringement scheme and cause harm to Plaintiff. Moreover, Defendants are using Plaintiff's Work to drive Internet consumer traffic to their e-commerce stores operating under the Seller IDs, thereby creating and increasing

the value of the Seller IDs and decreasing the size and value of Plaintiff's legitimate consumer marketplace at Plaintiff's expense.

### **COMMON FACTUAL ALLEGATIONS**

#### **Plaintiff's Business, Photographs, Trademark, Trade Dress, and Patent Rights**

27. Plaintiff is the owner of source identifying trademarks, including NEGG<sup>®</sup> (Reg. No. 5,142,630 attached as **Exhibit 1**) and trade dress shown in **Exhibit 2** that Plaintiff uses to distinguish its unique product ("Plaintiff's Marks"). Plaintiff owns the overall combination and arrangement of all non-functional design elements of Plaintiff's product and packaging, including its product insert, which are inherently distinctive and/or have acquired secondary meaning in the mind of the purchasing public.

28. Plaintiff owns a United States patent for its unique NEGG<sup>®</sup> product, including U.S. Patent No. 9,968,211 for PERSONAL EGG PEELER (attached as **Exhibit 3**).

29. Plaintiff also owns copyrights for its packaging, including its product insert.

30. Plaintiff's trademark, trade dress, patent, and copyright rights make it unlawful for competitors to infringe Plaintiff's rights.

a. Because of Plaintiff's NEGG<sup>®</sup> registered trademark, no competitor can lawfully use Plaintiff's NEGG<sup>®</sup> registered trademark in a manner that could cause confusion as to source.

b. Because of Plaintiff's copyrights for its packaging and trade dress rights, no competitor can lawfully copy Plaintiff's copyrighted expression or use packaging that could cause a likelihood of confusion as to the source of the competing product.

c. Because of Plaintiff's patent on its NEGG<sup>®</sup> product, no competitor can lawfully make, use, offer for sale, or sell a competing product that infringes Plaintiff's patent.

31. Like many other rights owners, Plaintiff suffers ongoing daily and sustained violations of its copyright, trademark, trade dress, and patent rights at the hands of counterfeiters and infringers, such as Defendants herein. Plaintiff is harmed, the consuming public is duped and confused, and the Defendants earn substantial profits in connection with the infringing conduct.

32. In order to combat the harm caused by the combined actions of Defendants and others engaging in similar infringing conduct, Plaintiff has expended significant resources in connection with its intellectual property enforcement efforts. The recent explosion of infringement over the Internet has created an environment that requires companies to expend significant time and money across a wide spectrum of efforts in order to protect both consumers and itself from infringement of its copyrights, trademark rights and patent rights.

33. Upon information and belief, at all times relevant hereto, Defendants in this action had full knowledge of Plaintiff's copyrights, trademark rights, trade dress, and/or patent rights, including Plaintiff's exclusive right to use and license such intellectual property and the goodwill associated therewith. Plaintiff has complied with Section 29 of the Lanham Act (15 U.S.C. § 1111) and has provided actual notice of its trademark registration for NEGG<sup>®</sup>. *See* Plaintiff's product insert (**Exhibit 2**).

### **The Online Marketplace Platform and Defendants' User Accounts**

34. Online marketplace platforms (also referred to as "Third Party Service Provider"), including but not limited to Amazon.com, eBay.com, Alibaba.com, AliExpress.com, Temu,

TikTok, Walmart.com, and Wish.com, allow manufacturers, wholesalers and other third party merchants, like Defendants, to advertise, distribute, offer for sale, sell and ship their wholesale and retail products originating from China directly to consumers worldwide and specifically to consumers residing in the United States, including Pennsylvania.

35. Defendants are individuals and/or businesses, who, upon information and belief, are located in China and other foreign countries but conduct business in the United States and other countries by means of their User Accounts and on their Merchant Storefronts on Amazon.com as well as potentially yet undiscovered additional online marketplace platforms.

36. Through their Merchant Storefronts, Defendants offer for sale and/or sell consumer products, including Counterfeit Products, and target and ship such products to customers located in the United States, including Pennsylvania, and throughout the world.

### **DEFENDANTS' UNLAWFUL CONDUCT**

37. Defendants are promoting and advertising, distributing, selling and/or offering for sale copies of Plaintiff's NEGG<sup>®</sup> product in interstate commerce that infringes Plaintiff's trademark rights, trade dress rights, and patent rights (collectively referred to as, "Infringing Product(s)" or "Counterfeit Product(s)"), through the fully interactive Internet based e-commerce stores operating under the Seller IDs:

- a. The packaging for Defendants' competing goods uses identical copies of Plaintiff's Mark for different quality goods.
- b. The packaging for Defendants' competing goods copies large amounts of Plaintiff's claimed copyrighted expression for its packaging, and the similar trade dress creates a likelihood of confusion as to source.

c. Defendants' competing goods look nearly identical, which creates a likelihood of confusion as to source, as Defendants' competing goods are confusing similar imitations of Plaintiff's product.

d. Defendants make, use, offer for sale, or sell competing products that infringe Plaintiff's patent.

e. Some Defendants in related cases have used Plaintiff's NEGG<sup>®</sup> trademark on packaging or in advertisements to drive sales.

f. Defendants' competing goods are of a quality substantially and materially different than that of Plaintiff's genuine goods.

g. Defendants sell or offer the infringing goods for a retail price below the usual retail price of Plaintiff's genuine patented product.

38. E-commerce sales, including through e-commerce stores like those of Defendants, have resulted in a sharp increase in the shipment of unauthorized products into the United States. *Ference Dec<sup>2</sup>*, Exhibit 1, Excerpts from Fiscal Year 2021 U.S. Customs and Border Protection ("CBP") Intellectual Property Seizure Statistics Report. Over 89% of all CBP intellectual property seizures were smaller international mail and express shipments (as opposed to large shipping containers). *Id.* More than half (51%) of CBP seizures originated from mainland China and Hong Kong. *Id.* Counterfeit and pirated products account for billions in economic losses,

---

<sup>2</sup> Referring to Declaration of Stanley D. Ference III in Support of Temporary Restraining Order, filed herewith.

resulting in tens of thousands of lost jobs for legitimate businesses and broader economic losses, including lost tax revenue.

39. Third party service providers like those used by Defendants do not adequately subject new sellers to verification and confirmation of their identities, allowing counterfeiters to “routinely use false or inaccurate names and addresses when registering with these e-commerce platforms.” *Ference Dec.*, Exhibit 2, Daniel C.K. Chow, *Alibaba, Amazon, and Counterfeiting in the Age of the Internet*, 40 NW. J. INT’L L. & BUS. 157, 186 (2020); see also, report on “Combating Trafficking in Counterfeit and Pirated Goods” prepared by the U.S. Department of Homeland Security’s Office of Strategy, Policy, and Plans (Jan. 24, 2020), attached as *Ference Dec.*, Exhibit 3 and finding that on “at least some e-commerce platforms, little identifying information is necessary for a counterfeiter to begin selling” and recommending that “[s]ignificantly enhanced vetting of third-party sellers” is necessary. Counterfeiters hedge against the risk of being caught and having their websites taken down from an e-commerce platform by preemptively establishing multiple virtual store-fronts. *Ference Dec.*, Exhibit 3, at p. 22. Since platforms generally do not require a seller on a third-party marketplace to identify the underlying business entity, counterfeiters can have many different profiles that can appear unrelated even though they are commonly owned and operated. *Ference Dec.*, Exhibit 3 at p. 39. Further, “E-commerce platforms create bureaucratic or technical hurdles in helping brand owners to locate or identify sources of counterfeits and counterfeiters.” *Ference Dec.*, Exhibit 2 at 186-187.

40. Defendants target their business activities towards consumers throughout the United States, including within Pennsylvania, and this district in Allegheny County, and conduct pervasive business through the operation of, at least, one fully interactive commercial Internet

based e-commerce store via, at least, one of the Amazon.com, eBay.com, Alibaba.com, AliExpress.com, Temu.com, TikTok, Walmart.com, or Wish.com online marketplaces under various Seller IDs, including the Seller IDs in **Schedule “A”**.

41. Defendants have purposefully directed some portion of their illegal activities towards consumers in the Commonwealth of Pennsylvania through the advertisement, offer to sell, sale, and/or shipment of infringing goods into the State.

42. Defendants are the past and present controlling forces behind the sale of products that infringe Plaintiff’s intellectual property as described herein using at least the Seller IDs in **Schedule “A”** and the Seller IDs associated with the infringing product ASIN numbers. Defendants have registered, established or purchased, and maintained their Seller IDs.

43. Upon information and belief, some Defendants have anonymously registered and maintained some of the Seller IDs for the sole purpose of engaging in illegal counterfeiting or infringement activities. On Amazon.com after notice that a particular Seller Name has sold an infringing product with a particular ASIN number, a new Seller Name will be used (*e.g.* a new “Just Launched Seller”) to sell the same infringing product under a new ASIN number associated with the new Seller Name. The result can be a never ending “Whack–A-Mole” situation where new infringers keep popping up.

44. Upon information and belief, Defendants will continue to register or acquire new Seller ID aliases for the purpose of selling and offering for sale goods that infringe Plaintiff’s trademark rights, trade dress rights, and patent rights unless preliminarily and permanently enjoined.

45. Defendants' business names, *i.e.*, Seller IDs, associated payment accounts, and any other alias seller identification names used in connection with the sale of infringing goods are essential components of Defendants' online activities and are one of the means by which Defendants further their infringing scheme and cause harm to Plaintiff. Moreover, Defendants are using without permission Plaintiff's claimed copyrightable materials, trademarks, trade dress and patents to drive Internet consumer traffic to their e-commerce stores operating under their Seller IDs, thereby increasing the value of the Seller IDs and decreasing the size and value of Plaintiff's legitimate marketplace and intellectual property rights at Plaintiff's expense.

46. Upon information and belief, Defendants are concurrently targeting their infringing activities toward consumers and causing harm within this district and elsewhere throughout the United States. As a result, Defendants are harming Plaintiff and the consuming public for Defendants' own benefit.

47. By their actions, Defendants have created an illegal marketplace operating in parallel to the legitimate marketplace for Plaintiff's genuine goods. Defendants are causing concurrent and indivisible harm to Plaintiff and the consuming public by (i) depriving Plaintiff and other third parties of their right to fairly compete for space within search engine results and reducing the visibility of Plaintiff's genuine goods on the World Wide Web and internet, including on Amazon.com, (ii) causing an overall degradation of the value of the goodwill associated with Plaintiff's trademark rights, and (iii) increasing Plaintiff's overall cost to market its goods and educate consumers about its brand via the Internet.

48. Plaintiff is suffering irreparable and indivisible injury and has suffered substantial damages as a result of Defendants' unauthorized and wrongful use of Plaintiff's intellectual property. The natural and intended byproduct of Defendants' actions is the erosion and

destruction of the goodwill associated with Plaintiff's name and associated trademarks and the destruction of the legitimate market sector in which it operates.

49. Defendants' infringing products compete directly against Plaintiff's products. Defendants' infringement was a cause in Plaintiff's unit sales decreasing during the last several months over the same time period the previous year. Plaintiff has thus lost profits.

50. Plaintiff has suffered and will suffer irreparable injury as a result of Defendants' continued sale of infringing products, and monetary damages are inadequate to compensate Plaintiff for Defendants' continued sale of infringing products.

a. Defendants sell cheaper and inferior competing egg peeler products that infringe upon Plaintiff's claimed copyrightable materials, trademarks, trade dress, and patents. Defendants' sale of infringing products has caused Plaintiff loss of market share, reputational harm, lost profits and/or jeopardy to Plaintiff's competitive position.

b. Plaintiff cannot effectively exercise its rights under copyright, trademark, trade dress, and patent which also damages Plaintiff's relationship with its actual and/or potential re-sellers.

c. Defendants have infringed in the past and threaten to infringe in the future.

51. Upon information and belief, Defendants' payment and financial accounts are being used by Defendants to accept, receive, and deposit profits from Defendants' trademark counterfeiting and infringing and unfairly competitive activities connected to their Seller IDs and any other alias domain names or seller identification names being used and/or controlled by them.

52. Plaintiff has no adequate remedy at law. Upon information and belief, Defendants are likely to transfer or secret their assets to avoid payment of any monetary judgment awarded to Plaintiff.

53. Defendants would suffer no cognizable harm from ceasing infringing conduct.

a. Defendants have no right to sell products that infringe Plaintiff's copyrights, trademark rights, trade dress rights, and patent rights.

b. Defendants sell other products, so they would suffer little harm if they stopped selling the infringing products at issue in this lawsuit.

c. Plaintiff will suffer great harm to its competitive position and business if Defendants sell products that infringe Plaintiff's rights.

54. The public interest will be served when it protects Plaintiff from infringement of its copyright, trademark and/or patent rights.

55. Defendants are engaging in the above-described illegal counterfeiting and infringing activities knowingly and intentionally or with reckless disregard or willful blindness to Plaintiff's rights. If Defendants' infringing activities are not preliminarily and permanently enjoined by this Court, Plaintiff and the consuming public will continue to be harmed.

56. The harm and damages sustained by Plaintiff have been directly and proximately caused by Defendants' wrongful reproduction, use, advertisement, promotion, offers to sell, and sale of their Infringing Products.

## **Scope of Defendants' Unlawful Activities**

57. Upon information and belief, each Defendant did not obtain an opinion from United States Counsel about the legality of offering for sale its Infringing Products.

58. Upon information and belief, each Defendant operates more than one merchant storefront.

59. Upon information and belief, each Defendant operates merchant storefronts across multiple e-commerce marketplaces.

60. Upon information and belief, each Defendant has sold more than 150,000 units of the Infringing Product with at least \$10.00 profit per unit.

61. Upon information and belief, each Defendant's profits from the sale of the Infringing Products totals more than \$100,000.

62. Upon information and belief, each Defendant's profits from the sale of the Infringing Products totals more than \$300,000.

63. Upon information and belief, each Defendant's profits from the sale of the Infringing Products totals more than \$2,000,000.

### **COUNT I – PATENT INFRINGEMENT (35 U.S.C. § 271(a))**

64. Plaintiff hereby adopts and re-alleges the allegations set forth in the preceding paragraphs as if set forth herein.

65. Plaintiff is the owner of U.S. Patent No. 9,968,211 (“the ‘211 patent”), issued May 15, 2018, for “PERSONAL EGG PEELER” and which covers Plaintiff's NEGG<sup>®</sup> product. A true and correct copy of which is attached as **Exhibit 3**.

66. Defendants have infringed and continue to infringe the '211 patent either directly or indirectly through acts of contributory infringement or inducement in violation of 35 U.S.C. § 271, by making, using, selling, importing and/or offering to sell infringing products, namely the personal egg peelers that are nearly identical to Plaintiff's NEGG<sup>®</sup> product. *Ference Dec.*,

**Exhibit 4.**

67. Defendants' infringement, contributory infringement and/or inducement to infringe has injured Plaintiff and it, therefore, is entitled to recover damages adequate to compensate it for such infringement, but in no event less than a reasonable royalty.

68. Defendants' infringement, contributory infringement and/or inducement to infringe has been willful and deliberate because Defendants have notice of or knew of the '211 patent and have nonetheless injured and will continue to injure Plaintiff, unless and until this Court enters an injunction, which prohibits further infringement and specifically enjoins further manufacture, use, sale, importation and/or offer for sale of products or services that come within the scope of the '211 patent.

69. Based on Defendants' wrongful conduct, Plaintiff is entitled to injunctive relief as well as monetary damages and other remedies as provided by the Patent Act, including damages that Plaintiff has sustained and will sustain as a result of Defendants' illegal and infringing actions as alleged herein, enhanced discretionary damages and reasonable attorneys' fees and costs.

**COUNT II – FEDERAL COPYRIGHT INFRINGEMENT (17 U.S.C. § 501(a))**

70. All the above paragraphs are incorporated herein by reference.

71. Plaintiff is the exclusive owner and licensee of Plaintiff's Works.

72. Defendants had actual notice of Plaintiff's exclusive rights in and to the Plaintiff's Works.

73. Defendants did not attempt and therefore inherently failed to obtain Plaintiff's consent or authorization to use, manufacture, reproduce, copy, display, prepare derivative works of, distribute, sell, transfer, rent, perform and/or market Plaintiff's Works.

74. Defendants' unlawful actions have caused and are continuing to cause unquantifiable damages to Plaintiff and are unjustly enriching Defendants with profits at Plaintiff's expense.

75. Without permission, Defendants knowingly and intentionally reproduced, copied, and displayed the Plaintiff's Works by manufacturing, importing, exporting, advertising, marketing, promoting, distributing, displaying, offering for sale and/or selling products that utilize features that are, at a minimum, substantially similar to the Plaintiff's Works. Defendants' unlawful and willful action as alleged herein constitute infringement of the Plaintiff's Works, including plaintiff's exclusive rights to reproduce, distribute and/or sell such Works in violation of 17 U.S.C. § 501(a).

76. Defendants' knowing and intentional copyright infringement, as alleged herein, has caused substantial and irreparable harm to Plaintiff in an amount as yet unknown but to be proven at trial, for which Plaintiff has no adequate remedy at law, and unless enjoined, Defendants will continue to cause substantial and irreparable harm to Plaintiff. Plaintiff is entitled to injunctive relief, Plaintiff's actual damages and Defendants' profits in an amount to be proven at trial, enhanced discretionary damages for willful copyright infringement, and reasonable attorneys' fees and costs.

**COUNT III - FALSE DESIGNATION OF ORIGIN, PASSING OFF & UNFAIR COMPETITION PURSUANT TO § 43(a) OF THE LANHAM ACT (15 U.S.C. § 1125(a))**

77. Plaintiff hereby adopts and re-allege the allegations set forth in the preceding paragraphs as if set forth herein.

78. The Defendants have made and sold in interstate commerce Infringing Goods that embody Plaintiff's Trade Dress, including, using Plaintiff's Works and/or Trade Dress as a means to attract, divert and take sales from Plaintiff, thus unfairly competing.

79. As result of the Defendants' conduct as set forth herein, consumers could be confused and induced to purchase the Defendants' Infringing Goods, mistakenly believing them to be Plaintiff's Product, thus depriving Plaintiff of the profits for sale.

80. Defendants' Infringing Goods using, offered for sale, and sold under copies of Plaintiff's Mark are virtually identical in appearance to Plaintiff's respective, genuine goods. However, Defendants' Infringing Goods are different and likely inferior in quality. Accordingly, Defendants' activities are likely to cause confusion in the trade and among the general public as to at least the origin or sponsorship of their Infringing Goods.

81. Defendants, upon information and belief, have used in connection with their advertisement, offers for sale, and sale of the Infringing Goods, false designations of origin and false descriptions and representations, including words or other symbols and trade dress which tend to falsely describe or represent such goods and have caused such goods to enter into commerce with full knowledge of the falsity of such designations of origin and such descriptions and representations, all to Plaintiff's detriment.

82. Defendants have authorized infringing uses of Plaintiff's Trade Dress in Defendants' advertisement and promotion of their Infringing and infringing branded goods. Defendants have also misrepresented to members of the consuming public that the Infringing Goods being advertised and sold by them are genuine, non-infringing goods.

83. Defendants knowingly and willfully used in commerce products and/or packaging designs that are identical or confusingly similar to, and constitute reproductions of Plaintiff's Works and Trade Dress and affixed, applied and used false designations of origin and false and misleading descriptions and representations on or in connection with the manufacturing, importing, exporting, advertising, marketing, promoting, distributing, displaying, offering for sale and/or sale of Infringing Products with the intent to cause confusion, to cause mistake and to deceive the purchasing public into believing, in error, that Defendants' substandard Infringing Goods are Plaintiff's or related products, and/or that Defendants' Infringing Goods are authorized, sponsored, approved, endorsed or licensed by Plaintiff and/or that Defendants are affiliated, connected or associated with Plaintiff, thereby creating a likelihood of confusion by consumers as to the source of such Infringing Goods, and allowing Defendants to capitalize on the goodwill associated with, and the consumer recognition of, the Plaintiff's Trade Dress and products, to Defendants' substantial profit in blatant disregard of Plaintiff's rights.

84. Additionally, Defendants are using infringements of Plaintiff's Trade Dress in order to unfairly compete with Plaintiff and others for space within search engine organic results, thereby jointly depriving Plaintiff of a valuable marketing and educational tool which would otherwise be available to Plaintiff and reducing the visibility of Plaintiff's genuine goods on the World Wide Web.

85. Defendants' above-described actions are in violation of Section 43(a) of the Lanham Act, 15 U.S.C. §1125(a).

86. Plaintiff has no adequate remedy at law, and has sustained indivisible injury and damage caused by Defendants' concurrent conduct. Absent an entry of an injunction by this Court, Defendants will continue to wrongfully reap profits and Plaintiff will continue to suffer irreparable injury to its respective goodwill and business reputations, as well as monetary damages.

87. Based on Defendants' wrongful conduct, Plaintiff is entitled to injunctive relief as well as monetary damages and other remedies as provided by the Lanham Act, including damages that Plaintiff has sustained and will sustain as a result of Defendants' illegal and infringing actions as alleged herein, and all gains, profits and advantages obtained by Defendants as a result thereof, enhanced discretionary damages and reasonable attorneys' fees and costs.

#### **COUNT IV - COMMON LAW UNFAIR COMPETITION**

88. Plaintiff hereby adopts and re-allege the allegations set forth in the preceding paragraphs as if set forth herein.

89. This is an action against Defendants based on their promotion, advertisement, distribution, sale, and/or offering for sale of goods bearing and/or using marks that are virtually identical, both visually and phonetically, to Plaintiff's Trade Dress in violation of Pennsylvania's common law of unfair competition.

90. Specifically, Defendants are promoting and otherwise advertising, selling, offering for sale, and distributing goods bearing and/or using infringements of Plaintiff's Trade Dress. Defendants are also using infringements of Plaintiff's Trade Dress to unfairly compete on online

marketplaces with Plaintiff and others for space in marketplace search results across an array of search terms, including but not limited to Plaintiff's Mark.

91. Defendants' infringing activities are likely to cause and actually are causing confusion, mistake, and deception among members of the trade and the general consuming public as to the origin and quality of Defendants' products by their use of Plaintiff's Trade Dress.

92. Plaintiff has no adequate remedy at law and are suffering irreparable injury and damages as a result of Defendants' actions.

93. As a result of Defendants' actions alleged herein, Plaintiff is entitled to injunctive relief, an order granting Plaintiff's damages and Defendants' profits stemming from their infringing activities, and exemplary or punitive damages for Defendants' intentional misconduct.

#### **PRAYER FOR RELIEF**

**WHEREFORE**, Plaintiff demands judgment on all Counts of this Complaint and an award of equitable relief and monetary relief against Defendants as follows:

a. Entry of temporary, preliminary and permanent injunctions pursuant to 15 U.S.C. § 1116, 35 U.S.C. § 283, and Federal Rule of Civil Procedure 65 enjoining Defendants, their agents, representatives, servants, employees, and all those acting in concert or participation therewith, from manufacturing or causing to be manufactured, importing, advertising or promoting, distributing, selling or offering to sell their Infringing Goods that infringe on Plaintiff's Patent; from infringing, or diluting Plaintiff's Trade Dress; from using Plaintiff's Mark, or any mark or trade dress similar thereto; from using Plaintiff's Works or substantially similar copies of Plaintiff's Works, in connection with the sale of any unauthorized goods; from using any logo, trade name or trademark or trade dress that may be calculated to falsely advertise

the services or goods of Defendants as being sponsored by, authorized by, endorsed by, or in any way associated with Plaintiff; from falsely representing themselves as being connected with Plaintiff, through sponsorship or association, or engaging in any act that is likely to falsely cause members of the trade and/or of the purchasing public to believe any goods or services of Defendants are in any way endorsed by, approved by, and/or associated with Plaintiff; from using any reproduction, infringing, infringement, copy, or colorable imitation of Plaintiff's Mark or Works in connection with the publicity, promotion, sale, or advertising of any goods sold by Defendants; from affixing, applying, annexing or using in connection with the sale of any goods, a false description or representation, including words or other symbols tending to falsely describe or represent Defendants' goods as being those of Plaintiff, or in any way endorsed by Plaintiff and from offering such goods in commerce; from engaging in search engine optimization strategies using colorable imitations of Plaintiff's name or trademark; from further infringement, inducement and contributory infringement of the patent-in-suit; and from otherwise unfairly competing with Plaintiff.

c. Entry of an Order that, upon Plaintiff's request, any Internet marketplace website operators and/or administrators that are provided with notice of the injunction, including but not limited to Amazon.com, eBay.com, Alibaba.com, AliExpress.com, Temu.com, TikTok, Walmart.com and Wish.com, identify any e-mail address known to be associated with Defendants' respective Seller ID, and cease facilitating access to any or all e-commerce stores through which Defendants engage in the promotion, offering for sale, and/or sale of goods bearing and/or using infringements of Plaintiff's Works or Marks.

d. Entry of an Order that, upon Plaintiff's request, any Internet marketplace website operators and/or administrators who are provided with notice of the injunction, including but not

limited to Amazon.com, eBay.com, Alibaba.com, AliExpress.com, Temu.com, TikTok, Walmart.com, and Wish.com, permanently remove any and all listings and associated images of Infringing Goods that infringe on Plaintiff's Patent; from infringing, or diluting Plaintiff's Trade Dress; from using Plaintiff's Mark, or any mark or trade dress similar thereto; from using Plaintiff's Works or substantially similar copies of Plaintiff's Works, via the e-commerce stores operating under the Seller IDs, including any and all listings and images of goods bearing and/or using infringements of Plaintiff's Mark or Works, or copies of that are substantially similar, linked to the same seller or linked to any other alias seller identification name being used and/or controlled by Defendants to promote, offer for sale and/or sell goods bearing and/or using infringements of Plaintiff's Marks or Works.

e. Entry of an Order that, upon Plaintiff's request, any Internet marketplace website operators and/or administrators who are provided with notice of the injunction, including but not limited to Amazon.com, eBay.com, Alibaba.com, AliExpress.com, Temu.com, TikTok, Walmart.com, and Wish.com, immediately cease fulfillment of and sequester all Infringing Goods that infringe on Plaintiff's Patent; from infringing, or diluting Plaintiff's Trade Dress; from using Plaintiff's Mark, or any mark or trade dress similar thereto; from using Plaintiff's Works or substantially similar copies of Plaintiff's Works, in its inventory, possession, custody, or control, and surrender those goods to Plaintiff.

f. Entry of an order requiring Defendants to account to and pay Plaintiff for all profits and damages resulting from Defendants' infringing and unfairly competitive activities and that the award to Plaintiff be trebled, as provided for under 15 U.S.C. §1117.

g. Entry of an award pursuant to 15 U.S.C. § 1117 (a) and (b) of Plaintiff's costs and reasonable attorneys' fees and investigative fees associated with bringing this action.

h. For an award of Plaintiff's actual damages and Defendants' profits, pursuant to 17 U.S.C. § 504(b), in an amount to be proven at trial for willful copyright infringement of the Plaintiff's Works under § 501(a).

i. In the alternative to Plaintiff's actual damages and Defendants' profits for copyright infringement of the Plaintiff's Works pursuant to 17 U.S.C. § 504 (b), for statutory damages of \$150,000.00 per infringement pursuant to 17 U.S.C. § 504 (c) for willful copyright infringement, which Plaintiff may elect prior to the rendering of a final judgment, together with Plaintiff's costs and reasonable attorney's fees and investigative fees associated with bringing this action.

j. Entry of an Order awarding Plaintiff damages adequate to compensate for the infringement of its patent, but in no event less than a reasonable royalty for the use made of the invention by the Defendants, together with interest and costs as fixed by the Court pursuant to 35 U.S.C. § 284 and/or 35 U.S. Code § 289, and that the award be trebled as provided for under 35 U.S.C. § 284.

k. Entry of an Order finding that this case is exceptional and an award to Plaintiff of its attorney fees and costs as provided for under 35 U.S.C. § 285.

l. Entry of an Order that, upon Plaintiff's request, any financial institutions, payment processors, banks, escrow services, money transmitters, or marketplace platforms, and their related companies and affiliates, identify and restrain all funds, up to and including the total amount of judgment, in all financial accounts and/or sub-accounts used in connection with the Seller IDs or other domain names, alias seller identification names, or e-commerce store names or store URLs used by Defendants presently or in the future, as well as any other related accounts of the same customer(s) and any other accounts which transfer funds into the same

financial institution account(s), to be surrendered to Plaintiff in partial satisfaction of the monetary judgment entered herein.

m. Entry of an award of pre-judgment interest on the judgment amount.

n. Entry of an order for any further relief as the Court may deem just and proper.

**DEMAND FOR JURY TRIAL**

Plaintiff respectfully demands a trial by jury on all claims.

Respectfully submitted,

Dated: October 8, 2024

/s/ Stanley D. Ference III

Stanley D. Ference III

Pa. ID No. 59899

courts@ferencelaw.com

Brian Samuel Malkin

Pa. ID No. 70448

bmalkin@ferencelaw.com

FERENCE & ASSOCIATES LLC

409 Broad Street

Pittsburgh, Pennsylvania 15143

(412) 741-8400 - Telephone

(412) 741-9292 - Facsimile

Attorneys for Plaintiff

Airigan Solutions, LLC

**SCHEDULE “A”**  
**DEFENDANTS BY STORE NAME AND SELLER ID**

<b>Defendant Number</b>	<b>Store/Seller Name</b>	<b>Seller ID</b>
1	Morning Chef	102513028
2	bei jing zhi fu ke ji	102566552
3	JZEQBXXYL	102499924
4	KunMingWuHuass	101695096
5	lalaxiaohumaoyi	102580542
6	linlingliu	101593770
7	Rongxiang Trading	102485970
8	Songsiqing Trading	102503653
9	xinyahanzhuangshi	102566983
10	xulizhixingkeji	102579631
11	zhijianshangmao	101670105
12	Yiwu Baowo Trading Co., Ltd.	1601210777582
13	Yuhuan Aobo Plastic Industry Co., Ltd.	1601213377034
14	Ali-YY120 Store	1103742500
15	Ali-ZYAG-1 Store	1103741818
16	Ali-ZYAR-1 Store	1103843185
17	CHANSUNRUN YAYA Store	1101328979
18	Good Shape-Keep Store	1103317977
19	Hoaden Warm Cozy Home Store	1101936438
20	Imagination321 Store	1101651283
21	Magic666 Store	1103582030
22	My Childhood World Store	1103339289
23	Savor Store	1101850244
24	Shop1102675024 Store	1102669977
25	Shop1103257141 Store	1103258139
26	Shop1103580739 Store	1103572716
27	Shop1103620766 Store	1103618843
28	Shop1103652096 Store	1103667077
29	Shop1103847354 Store	1103846356
30	Sumory Store	1101293646
31	Ycyc0124 Store	1103788191
32	Imaginary Visions Ecommerce LLC	A3N4WI1LTOXGM7

<b>Defendant Number</b>	<b>Store/Seller Name</b>	<b>Seller ID</b>
33	OSCARLETT COMPANY LLC	A1MF3QLGIBNRG5
34	OL16 LLC	A14FLN1FOIUMMU
35	MARKETING FOREVER VISUET LLC	A3HB6FW8URIS6W
36	DQstore	58ea0f6340fc1e15a3671b10

**LISTING OF EXHIBITS**

- Exhibit 1 ..... U.S. Trademark Reg. No. 5,142,630 (NEGG®)
- Exhibit 2 ..... U.S. Copyright VA0002237199 and excerpt of deposit copy from same (yellow), and product insert
- Exhibit 3 ..... U.S. Patent No. 9,968,211 for PERSONAL EGG PEELER
- Exhibit 4 ..... Screenshots of Plaintiff's Website and Amazon Store

Complaint

EXHIBIT 1



## UNITED STATES PATENT AND TRADEMARK OFFICE

UNDER SECRETARY OF COMMERCE FOR INTELLECTUAL PROPERTY AND  
DIRECTOR OF THE UNITED STATES PATENT AND TRADEMARK OFFICE

JULY 3, 2018

PTAS

STANLEY D. FERENCE III  
409 BROAD STREET  
PITTSBURGH, PA 15143

**900456707**

### UNITED STATES PATENT AND TRADEMARK OFFICE NOTICE OF RECORDATION OF ASSIGNMENT DOCUMENT

THE ENCLOSED DOCUMENT HAS BEEN RECORDED BY THE ASSIGNMENT RECORDATION BRANCH OF THE U.S. PATENT AND TRADEMARK OFFICE. A COMPLETE COPY IS AVAILABLE AT THE ASSIGNMENT SEARCH ROOM ON THE REEL AND FRAME NUMBER REFERENCED BELOW.

PLEASE REVIEW ALL INFORMATION CONTAINED ON THIS NOTICE. THE INFORMATION CONTAINED ON THIS RECORDATION NOTICE REFLECTS THE DATA PRESENT IN THE PATENT AND TRADEMARK ASSIGNMENT SYSTEM. IF YOU SHOULD FIND ANY ERRORS OR HAVE QUESTIONS CONCERNING THIS NOTICE, YOU MAY CONTACT THE ASSIGNMENT RECORDATION BRANCH AT 571-272-3350. PLEASE SEND REQUEST FOR CORRECTION TO: U.S. PATENT AND TRADEMARK OFFICE, MAIL STOP: ASSIGNMENT RECORDATION BRANCH, P.O. BOX 1450, ALEXANDRIA, VA 22313.

RECORDATION DATE: 07/02/2018

REEL/FRAME: 6369/0707  
NUMBER OF PAGES: 2

BRIEF: ASSIGNS THE ENTIRE INTEREST

DOCKET NUMBER: 972.003

ASSIGNOR:  
TORGAN, SHEILA

DOC DATE: 06/01/2018  
CITIZENSHIP: UNITED STATES  
ENTITY: INDIVIDUAL

ASSIGNOR:  
TYLER, MARGARET

DOC DATE: 06/01/2018  
CITIZENSHIP: UNITED STATES  
ENTITY: INDIVIDUAL

ASSIGNEE:  
AIRIGAN SOLUTIONS, LLC  
  
107 JOHN STREET, SUITE 1-C  
SOUTHPORT, CONNECTICUT 06890

CITIZENSHIP: CONNECTICUT  
ENTITY: LIMITED LIABILITY COMPANY

SERIAL NUMBER: 86736673  
REGISTRATION NUMBER: 5142630  
MARK: NEGG  
DRAWING TYPE: STANDARD CHARACTER MARK

FILING DATE: 08/25/2015  
REGISTRATION DATE: 02/14/2017

ASSIGNMENT RECORDATION BRANCH  
PUBLIC RECORDS DIVISION

# United States of America

United States Patent and Trademark Office

## Negg

**Reg. No. 5,142,630**

**Registered Feb. 14, 2017**

**Int. Cl.: 8**

**Trademark**

**Principal Register**

Sheila Torgan (UNITED STATES INDIVIDUAL)  
4000 Congress Street  
Fairfield, CT 06824

Margaret Tyler (UNITED STATES INDIVIDUAL)  
105 Dunham Road  
Fairfield, CT 06824

CLASS 8: Manually operated device used for peeling eggs

FIRST USE 10-15-2015; IN COMMERCE 10-18-2015

THE MARK CONSISTS OF STANDARD CHARACTERS WITHOUT CLAIM TO ANY PARTICULAR FONT STYLE, SIZE OR COLOR

SER. NO. 86-736,673, FILED 08-25-2015  
JORDAN A BAKER, EXAMINING ATTORNEY



*Michelle K. Lee*

Director of the United States  
Patent and Trademark Office

**REQUIREMENTS TO MAINTAIN YOUR FEDERAL TRADEMARK REGISTRATION**

**WARNING: YOUR REGISTRATION WILL BE CANCELLED IF YOU DO NOT FILE THE DOCUMENTS BELOW DURING THE SPECIFIED TIME PERIODS.**

**Requirements in the First Ten Years\***

**What and When to File:**

- **First Filing Deadline:** You must file a Declaration of Use (or Excusable Nonuse) between the 5th and 6th years after the registration date. See 15 U.S.C. §§1058, 1141k. If the declaration is accepted, the registration will continue in force for the remainder of the ten-year period, calculated from the registration date, unless cancelled by an order of the Commissioner for Trademarks or a federal court.
- **Second Filing Deadline:** You must file a Declaration of Use (or Excusable Nonuse) and an Application for Renewal between the 9th and 10th years after the registration date.\* See 15 U.S.C. §1059.

**Requirements in Successive Ten-Year Periods\***

**What and When to File:**

- You must file a Declaration of Use (or Excusable Nonuse) and an Application for Renewal between every 9th and 10th-year period, calculated from the registration date.\*

**Grace Period Filings\***

The above documents will be accepted as timely if filed within six months after the deadlines listed above with the payment of an additional fee.

**\*ATTENTION MADRID PROTOCOL REGISTRANTS:** The holder of an international registration with an extension of protection to the United States under the Madrid Protocol must timely file the Declarations of Use (or Excusable Nonuse) referenced above directly with the United States Patent and Trademark Office (USPTO). The time periods for filing are based on the U.S. registration date (not the international registration date). The deadlines and grace periods for the Declarations of Use (or Excusable Nonuse) are identical to those for nationally issued registrations. See 15 U.S.C. §§1058, 1141k. However, owners of international registrations do not file renewal applications at the USPTO. Instead, the holder must file a renewal of the underlying international registration at the International Bureau of the World Intellectual Property Organization, under Article 7 of the Madrid Protocol, before the expiration of each ten-year term of protection, calculated from the date of the international registration. See 15 U.S.C. §1141j. For more information and renewal forms for the international registration, see <http://www.wipo.int/madrid/en/>.

**NOTE: Fees and requirements for maintaining registrations are subject to change. Please check the USPTO website for further information. With the exception of renewal applications for registered extensions of protection, you can file the registration maintenance documents referenced above online at <http://www.uspto.gov>.**

**NOTE: A courtesy e-mail reminder of USPTO maintenance filing deadlines will be sent to trademark owners/holders who authorize e-mail communication and maintain a current e-mail address with the USPTO. To ensure that e-mail is authorized and your address is current, please use the Trademark Electronic Application System (TEAS) Correspondence Address and Change of Owner Address Forms available at <http://www.uspto.gov>.**

Complaint

EXHIBIT 2

## Detail record view

Registration record VA0002237199

Copyright Catalog

◀ Previous Next ▶

**The Negg Product Packaging V4.**

Share ◀ Actions ▼

<b>Registration Number / Date</b>	VA0002237199 / 2020-02-25
<b>Type of Work</b>	Visual Material
<b>Title</b>	The Negg Product Packaging V4.
<b>Application Title</b>	The Negg Product Packaging V4.
<b>Date of Creation</b>	2017
<b>Date of Publication</b>	2017-08-15
<b>Copyright Claimant</b>	Airigan Solutions, LLC. Address: 107 John Street, Suite 1-C, Southport, CT, 06890, United States.
<b>Authorship on Application</b>	Airigan Solutions, LLC, Domicile: United States. employer for hire; Authorship: photograph.
<b>Basis of Claim</b>	photograph.
<b>Rights and Permissions</b>	Ference & Associates LLC, 409 Broad Street, Pittsburgh, PA, 15143, United States
<b>Pre-existing Material</b>	photograph.
<b>Description</b>	Electronic file (eService)
<b>Copyright Note</b>	C.O. correspondence.
<b>Nation of First Publication</b>	United States
<b>Names</b>	<a href="#">Airigan Solutions, LLC</a>

Easy, Fast  
& Fun!

The  
Negg™

# egg peeler

Easy, Fast & Fun!

# egg peeler

**Simple to Use:**

**ADD** a little water and  
your boiled egg.

**SNAP** on the cap.

**SHAKE** up and down.

**SLIDE** off the shell.



Easy, Fast & Fun!

# egg peeler



The  
Negg

1 White  
Egg  
Peeler

Easy, Fast & Fun!  
**egg peeler**

If you like hard boiled eggs,  
**The Negg™** is a kitchen essential.

- BPA Free
- Dishwasher Safe
- Food Safe
- Available in multiple colors



For tips, tricks and some great recipes,  
visit us at [www.neggmaker.com](http://www.neggmaker.com)

The NEGG™ is a trademark of Airigan Solutions, LLC  
Patent Pending  
©2017 Airigan Solutions, LLC  
Airigan Solutions, LLC, 107 John Street, Southport, CT 06890



Easy, Fast & Fun!  
**egg peeler**



**1** White Egg Peeler



Easy, Fast & Fun!  
**egg peeler**



If you like hard boiled eggs **The Negg™**  
is a kitchen essential.

For tips, tricks and some great recipes, visit us

[www.neggmaker.com](http://www.neggmaker.com)

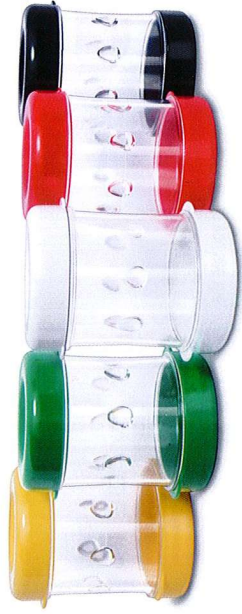

Airigan Solutions, LLC 107 John Street, Southport, CT 06890 Questions? Call us! (203) 594-7781

Easy, Fast  
& Fun!



# egg peeler

- BPA Free
- Dishwasher Safe (top rack)
- Food Safe
- Available in multiple colors

## Simple to Use:

**ADD** a little water and your boiled egg.



**SNAP** on the cap and **SHAKE** a few times!



**SLIDE** off the shell and **ENJOY!**



MADE IN  U. S. A.

The shaking should be vigorous, enough to fracture the shell and membrane. Check after 4 or so shakes. You should feel the shell "soften". When you see the white visible, you're done!

NEGG™ is a registered trademark of Airigan Solutions, LLC  
Patent Pending ©2017 Airigan Solutions, LLC

## The BEST Boiled Egg Recipe: Recommended by The Negg™

### Extra-Large Chicken Eggs

Bring a pot of water to a boil. Using a slotted spoon or ladle, carefully place your eggs in the boiling water.

When the water returns to a boil, cook the eggs for 12 minutes. Immediately remove the eggs from the hot water and place them in a bowl of ice water for 3 to 5 minutes before peeling.

#### NOTE:

As a general rule, adjust the cooking time by 1 minute—up or down—depending on the size of your eggs.

Complaint

EXHIBIT 3



## UNITED STATES PATENT AND TRADEMARK OFFICE

UNDER SECRETARY OF COMMERCE FOR INTELLECTUAL PROPERTY AND  
DIRECTOR OF THE UNITED STATES PATENT AND TRADEMARK OFFICE

JULY 3, 2018

PTAS

FERENCE & ASSOCIATES LLC  
409 BROAD STREET  
PITTSBURGH, PA 15143

**504987176**

### UNITED STATES PATENT AND TRADEMARK OFFICE NOTICE OF RECORDATION OF ASSIGNMENT DOCUMENT

THE ENCLOSED DOCUMENT HAS BEEN RECORDED BY THE ASSIGNMENT RECORDATION BRANCH OF THE U.S. PATENT AND TRADEMARK OFFICE. A COMPLETE COPY IS AVAILABLE AT THE ASSIGNMENT SEARCH ROOM ON THE REEL AND FRAME NUMBER REFERENCED BELOW.

PLEASE REVIEW ALL INFORMATION CONTAINED ON THIS NOTICE. THE INFORMATION CONTAINED ON THIS RECORDATION NOTICE REFLECTS THE DATA PRESENT IN THE PATENT AND TRADEMARK ASSIGNMENT SYSTEM. IF YOU SHOULD FIND ANY ERRORS OR HAVE QUESTIONS CONCERNING THIS NOTICE, YOU MAY CONTACT THE ASSIGNMENT RECORDATION BRANCH AT 571-272-3350. PLEASE SEND REQUEST FOR CORRECTION TO: U.S. PATENT AND TRADEMARK OFFICE, MAIL STOP: ASSIGNMENT RECORDATION BRANCH, P.O. BOX 1450, ALEXANDRIA, VA 22313.

RECORDATION DATE: 07/02/2018

REEL/FRAME: 046255/0183  
NUMBER OF PAGES: 2

BRIEF: ASSIGNMENT OF ASSIGNORS INTEREST (SEE DOCUMENT FOR DETAILS).

DOCKET NUMBER: 972.003

ASSIGNOR:  
TYLER, MARGARET B.

DOC DATE: 06/01/2018

ASSIGNOR:  
TORGAN, SHEILA M.

DOC DATE: 06/01/2018

ASSIGNEE:  
AIRIGAN SOLUTIONS, LLC  
107 JOHN STREET  
SUITE 1-C  
SOUTHPORT, CONNECTICUT 06890

APPLICATION NUMBER: 15156785  
PATENT NUMBER: 9968211  
TITLE: PERSONAL EGG PEELER

FILING DATE: 05/17/2016  
ISSUE DATE: 05/15/2018

ASSIGNMENT RECORDATION BRANCH  
PUBLIC RECORDS DIVISION



US009968211B2

(12) **United States Patent**  
**Tyler**

(10) **Patent No.:** **US 9,968,211 B2**  
(45) **Date of Patent:** **May 15, 2018**

(54) **PERSONAL EGG PEELER**

(71) Applicant: **Margaret B Tyler**, Fairfield, CT (US)

(72) Inventor: **Margaret B Tyler**, Fairfield, CT (US)

(\* ) Notice: Subject to any disclaimer, the term of this patent is extended or adjusted under 35 U.S.C. 154(b) by 165 days.

(21) Appl. No.: **15/156,785**

(22) Filed: **May 17, 2016**

(65) **Prior Publication Data**

US 2016/0338515 A1 Nov. 24, 2016

**Related U.S. Application Data**

(60) Provisional application No. 62/163,062, filed on May 18, 2015.

(51) **Int. Cl.**  
**A47G 19/28** (2006.01)

(52) **U.S. Cl.**  
CPC ..... **A47G 19/28** (2013.01)

(58) **Field of Classification Search**  
CPC ..... A47G 19/28; A47J 43/14  
USPC ..... 99/568, 571, 577, 586, 587, 588  
See application file for complete search history.

(56) **References Cited**

U.S. PATENT DOCUMENTS

1,030,324 A *	6/1912	Pender	.....	A47G 19/28
				30/120.1
2,962,067 A *	11/1960	Mesojedec	.....	A47G 19/28
				99/498
3,092,409 A *	6/1963	Murray	.....	A47G 19/28
				99/498
3,192,977 A *	7/1965	Bean	.....	A23N 7/01
				426/483
4,149,456 A	4/1979	Gisonni		
4,308,290 A	12/1981	Fujii		
5,573,803 A *	11/1996	Omessi	.....	A47J 17/02
				426/483
8,497,845 B2	7/2013	Braithwaite et al.		
2014/0004236 A1	1/2014	Braithwaite et al.		

\* cited by examiner

*Primary Examiner* — Reginald L Alexander

(74) *Attorney, Agent, or Firm* — John L Sotomayor

(57) **ABSTRACT**

An apparatus is described that permits a user to quickly and effortlessly separate an egg shell from the body of a hard-boiled egg. The apparatus has a hollow body into which an egg is inserted, a convex shaped bottom section and a convex shaped top portion. Additionally, the interior surface of the hollow body has a number of protrusions that contribute to peeling action. Eggs are inserted into the apparatus, water is added, the apparatus is sealed, the user agitates the apparatus for a short time, and then pours out the separated egg and egg shell along with the water.

**10 Claims, 5 Drawing Sheets**

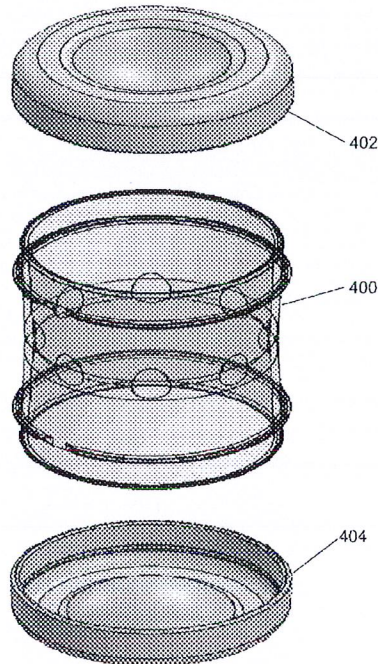

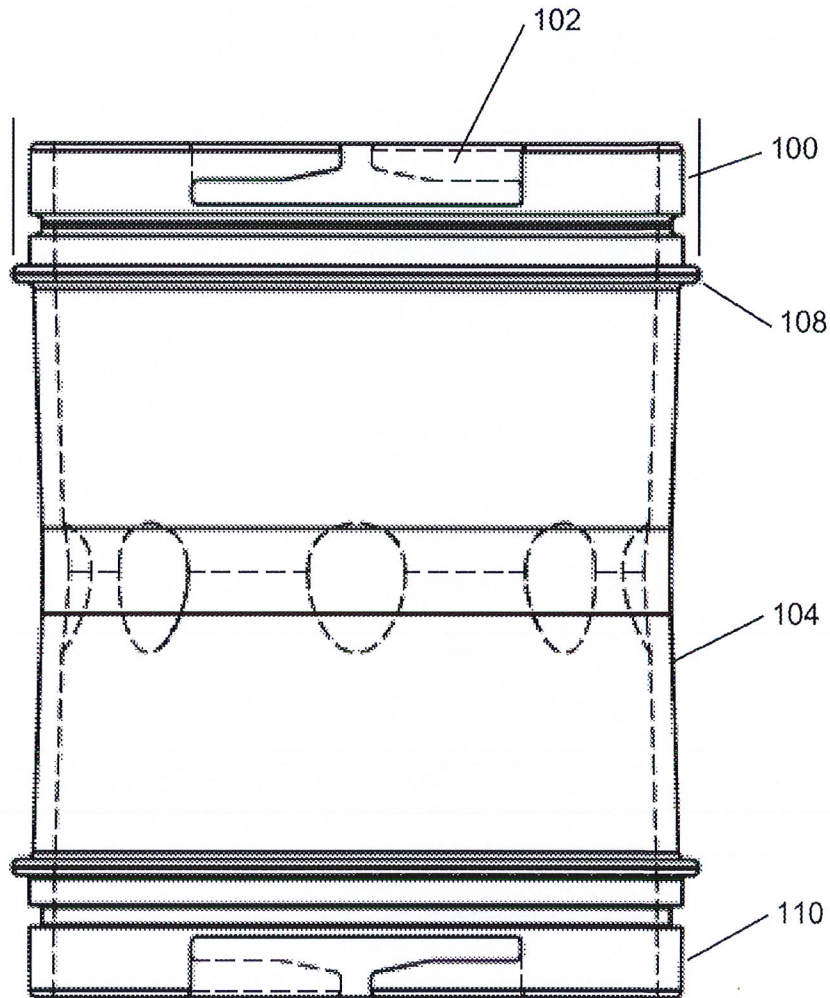

FIGURE 1

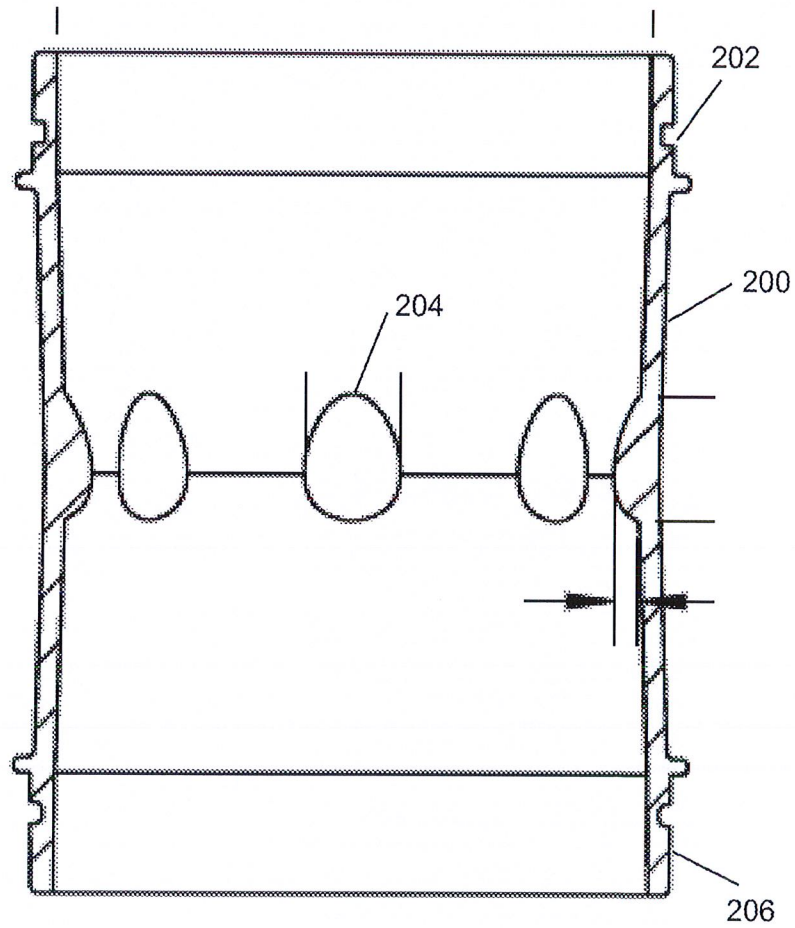

FIGURE 2

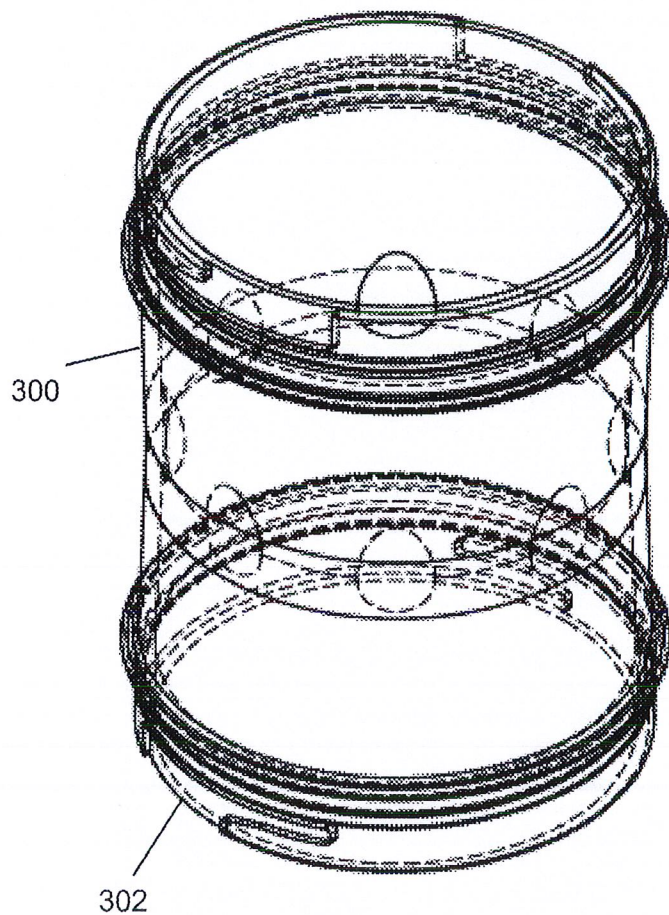

FIGURE 3

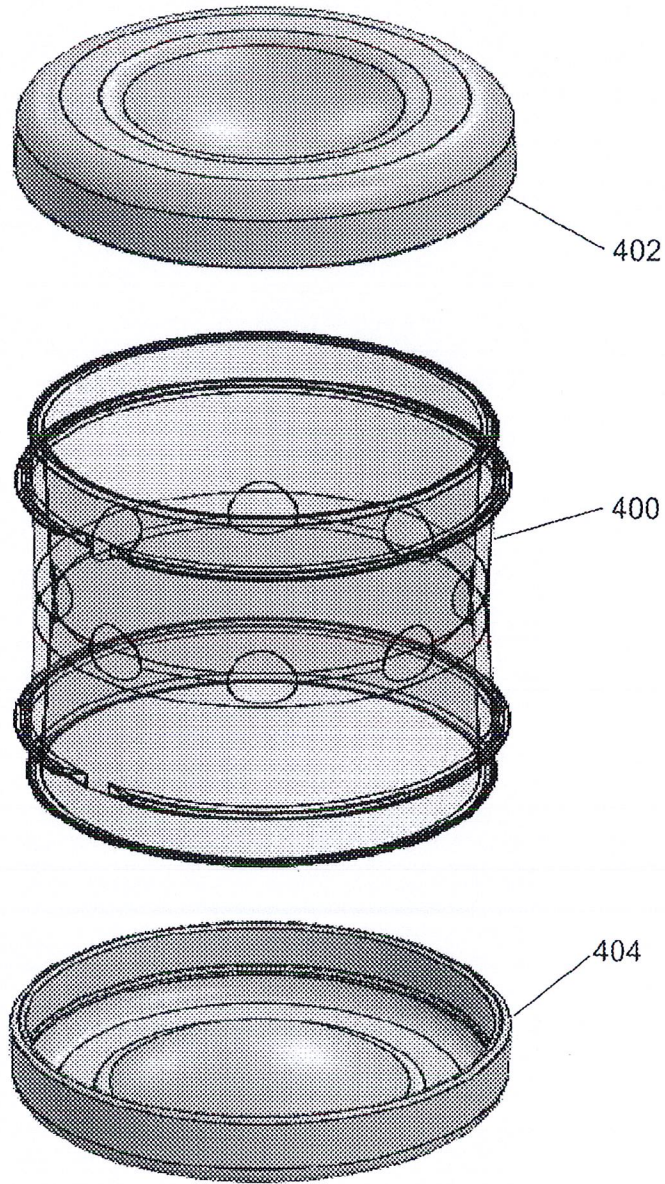

FIGURE 4

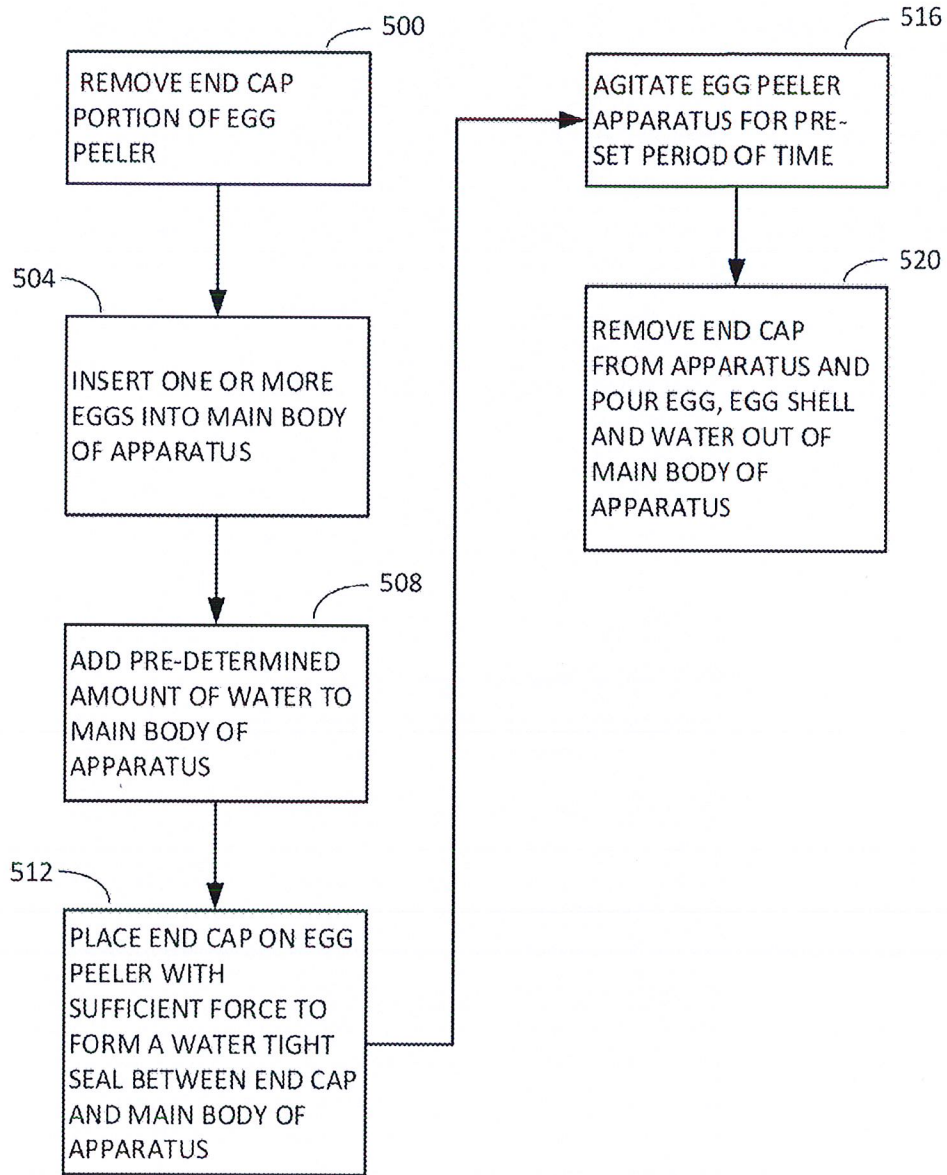

FIGURE 5

**PERSONAL EGG PEELER**

## PRIORITY CLAIM

This Non-Provisional application claims under 35 U.S.C. § 120, the benefit of priority to the Provisional Application 62/163,062, filed May 15, 2015, and Titled "Personal Egg Peeler" which is hereby incorporated by reference in its entirety.

## COPYRIGHT NOTICE

A portion of the disclosure of this patent document contains material which is subject to copyright protection. The copyright owner has no objection to the facsimile reproduction of the patent document or the patent disclosure, as it appears in the Patent and Trademark Office patent file or records, but otherwise reserves all copyright rights whatsoever.

## BACKGROUND

The present invention relates generally to food preparation, and specifically to preparing hard boiled eggs for consumption. Removing the shell of a hard-boiled egg is a tedious process, especially if there is little time prior to the consumption of the eggs. Commercial processes for removing the shell do not apply to home makers and other consumers of small numbers of eggs over a set period of time as the machines used are generally large, cumbersome, and expensive, although effective.

## BRIEF DESCRIPTION OF THE DRAWINGS

Certain illustrative embodiments illustrating organization and method of operation, together with objects and advantages may be best understood by reference detailed description that follows taken in conjunction with the accompanying drawings in which:

FIG. 1 is a view of the exterior of a personal egg peeler apparatus consistent with certain embodiments of the present invention.

FIG. 2 is a view of the main body of a personal egg peeler apparatus consistent with certain embodiments of the present invention.

FIG. 3 is a view of a main body and end portion connectors of a personal egg peeler consistent with certain embodiments of the present invention.

FIG. 4 is a view of a main body and end portion connectors of a personal egg peeler in an exploded view consistent with certain embodiments of the present invention.

FIG. 5 is a flow diagram for the operation of a personal egg peeler consistent with certain embodiments of the present invention.

## DETAILED DESCRIPTION

While this invention is susceptible of embodiment in many different forms, there is shown in the drawings and will herein be described in detail specific embodiments, with the understanding that the present disclosure of such embodiments is to be considered as an example of the principles and not intended to limit the invention to the specific embodiments shown and described. In the descrip-

tion below, like reference numerals are used to describe the same, similar or corresponding parts in the several views of the drawings.

The terms "a" or "an", as used herein, are defined as one or more than one. The term "plurality", as used herein, is defined as two or more than two. The term "another", as used herein, is defined as at least a second or more. The terms "including" and/or "having", as used herein, are defined as comprising (i.e., open language). The term "coupled", as used herein, is defined as connected, although not necessarily directly, and not necessarily mechanically.

Reference throughout this document to "one embodiment", "certain embodiments", "an embodiment" or similar terms means that a particular feature, structure, or characteristic described in connection with the embodiment is included in at least one embodiment of the present invention. Thus, the appearances of such phrases or in various places throughout this specification are not necessarily all referring to the same embodiment. Furthermore, the particular features, structures, or characteristics may be combined in any suitable manner in one or more embodiments without limitation.

A apparatus used for peeling commercial quantities of hard-boiled eggs, for use in such food items as egg-salad as an example, are often large, cumbersome, and expensive. The number of eggs to be peeled must, therefore, be quite large in order to justify the expense for such an apparatus.

Peeling more than a dozen, but less than a quantity that would justify the investment in a commercial size egg peeling apparatus, is a tedious, time-consuming task. However, peeling one, two, or a dozen hard-boiled eggs remains a tedious task, even though this process may not consume a large amount of time. There is a need for a personal egg peeler that removes the shell of a hard-boiled egg speedily and with little effort, while still remaining cost effective to purchase for a personal kitchen, or a low-volume commercial kitchen.

The egg peeler apparatus herein disclosed provides a low-cost, readily portable solution for the peeling of small quantities of hard-boiled eggs. The apparatus is configured to peel the eggs, separate the shell from the egg white, and perform this process in a very short time cycle. The apparatus consists of a cylindrical main body having convex end caps that are configured to be attached and removed from the cylindrical main body, and oval shaped protrusions extending from the interior surface of the cylindrical main body. The cylindrical main body is of sufficient diameter to permit the insertion of one or more eggs produced by a commercial variety hen. However, this should in no way be considered limiting as the cylindrical main body may be sized to accommodate eggs laid by other species of fowl as well.

The egg peeler has a top portion, also with a convex surface that faces the interior of the cylindrical main body, having a water tight connection and seal for sealing the apparatus when the top portion is connected to the main body. The convex end caps form the top and bottom portions of the apparatus when connected to the main body. Each end cap may have a water tight connection such as a gasket, an o-ring, a screw type fastener, or any other type of fastener that keeps water sealed inside the main body when the end caps are secured to the top and bottom portions of the main body. In operation, a user may remove the top portion of the egg peeler with the egg peeler oriented in a vertical plane, place one or more eggs of sufficient diameter to be fully enclosed by the main body of the egg peeler when inserted into the egg peeler, pour water sufficient to cover a third of the volume of the eggs when inserted into the main body,

and replace the top convex end cap onto the top of the cylinder with sufficient force to cause the convex top portion to seal the main body of the cylinder so as to retain both the egg and the water within the main body of the egg peeler. The user then shakes the egg peeler apparatus for a pre-

determined time and removes one of the convex end cap portions, unsealing the egg peeler main body to permit removal of the separated egg and egg shell portions from the cylindrical main body of the apparatus.

Although particular exemplary embodiments of the innovation will be presented herein, it should be apparent that additional embodiments may be accessible to those of ordinary skill in the art without departing from the spirit of innovation of the recited embodiments.

Turning now to FIG. 1, consistent with certain embodiments of the invention this figure is a view of the personal egg peeler apparatus consistent with certain embodiments of the present invention. In this exemplary embodiment, a top portion 100 of a personal egg peeler apparatus is presented as having a substantially circular cross section. However, this should in no way be considered limiting as the top portion 100 may be manufactured in any shape that is consistent with the shape of the main body of the personal egg peeler and may be oval, square, rectangular or any other shape that permits the top portion 100 to be inserted into or onto the top of the main body 104 of the personal egg peeler. The top portion 100 may also have a convex shaped portion 102 so as to permit a user to insert a thumb or fingers into the convex shaped portion 102 to readily grasp the top portion 100 of the personal egg peeler when in use.

The top portion 100 may have a sealing element 108 that is configured to form a closure that permits a water tight seal when the top portion 100 is reattached to the main body 104 of the personal egg peeler. The sealing element may consist of clip fastening, gasket, screw type element, o-ring element, slide and lock connection, or any other fastening structure that permits the top element 100 to be attached to and removed from the main body 104 of the personal egg peeler while maintaining a water tight seal when the top portion 100 is fully secured to the main body 104. The top portion 100 may also be manufactured of a material such as rubber, plastic, silicon, acrylic, or any other equivalent material, that permits a water tight seal to be maintained when the top portion 100 is fully secured onto the top portion of the main body 104 of the personal egg peeler.

The bottom portion 110 of the personal egg peeler may also be convex in shape. The convex shaped portion 102 of both the top portion 100 and the bottom portion 110 permits each end portion to participate in the action by forming a grip for a user to firmly grasp the personal egg peeler when in use. As such, it is readily apparent that the convex shaped portion 102 is not the only shape in which the top portion 100 and the bottom portion 110 of the personal egg peeler, such as a flat surface with protrusions, a wavy surface, a central cone, or any other shaped indentation, are equally disclosed as being consistent with the purpose of the convex shaped portion 102 of the top portion 100 and the bottom portion 110 of the personal egg peeler.

Turning now to FIG. 2, consistent with certain embodiments of the invention is a view of the main body of a personal egg peeler apparatus consistent with certain embodiments of the present invention. In an exemplary embodiment, the main body 200 of the personal egg peeler may be configured in any shape that permits the complete enclosure of one or more eggs when the eggs are inserted

into the main body 200. The main body 200 may be manufactured of any material, such as glass, plastic, acrylic, or any other material that is water proof and has a hardness greater than the hardness of the shell of an egg to be inserted. In a non-limiting example, the main body 200 of the personal egg peeler is presented as a hollow cylinder. However, the main body 200 could equally well be manufactured as a hollow square, rectangular, oval, or other shape that would permit the complete insertion of one or more eggs into the hollow portion of the main body 200.

The inner surface of the main body 200 may have raised protrusions 204 that extend into the hollow space within the main body 200. The raised protrusions 204 may be manufactured as a seamless portion of the interior surface of main body 200, or they may be manufactured separately and later attached to the interior surface of the main body 200. In this exemplary embodiment, the raised protrusions 204 contribute to the action of peeling the one or more eggs inserted into the personal egg peeler.

In an exemplary embodiment, the top portion 100 and bottom portion 110 of the personal egg peeler may be manufactured as separable end portions of the personal egg peeler. A top connector portion 202 and a bottom connector portion 206 may be shaped to form a locking connection with the top portion 100 and bottom portion 110 when placed in contact with the main body 200 of the personal egg peeler.

When preparing to use the personal egg peeler, either the top portion 100 or the bottom portion 110 may be removed from contact with the main body 200. At this point, one or more eggs may be inserted into the main body 200 of the apparatus making the apparatus ready for use in removing the peel from a hard-boiled egg or eggs, depending upon the size and configuration of the apparatus. Water is placed in the cavity of the main body 200 to a level that is approximately one third of the volume of the interior of the main body 200. Alternatively, in another exemplary embodiment, a water level marker may be indicated on the exterior of the apparatus to provide a user with a guideline for the water level that is preferred when using the apparatus. The top portion 100 or bottom portion 110, whichever was removed to permit the insertion of the egg(s) and water, is placed fully in contact with the main body 200 so as to form a sealed, water tight container around the one or more inserted eggs. The user may then firmly grasp the personal egg peeler by the top and bottom convex, or other shaped, portions and operate the apparatus by shaking the personal egg peeler vigorously.

In this exemplary embodiment, the top portion 100 and the bottom portion 110 of the apparatus are fully removable to facilitate cleaning of the interior of the main body 200 of the personal egg peeler apparatus.

Turning now to FIG. 3, consistent with certain embodiments of the invention is a view of a main body and end portion connectors of a personal egg peeler consistent with certain embodiments of the present invention. In this exemplary embodiment, the main body 300 of the personal egg peeler may be connected to a top capping portion and a bottom capping portion (not shown) through the connection point 302 formed as a part of the main body 300 top and bottom sections. The connection point 302 may be formed as a locking channel that permits the insertion of a top cap or a bottom cap and forming a water tight seal as the top cap and/or bottom cap are turned to secure the top cap or bottom cap in the locking channel. It is understood that a locking channel is simply one implementation of the water tight seal between the end caps and the main body 300 of the appa-

5

ratus. Additional sealing mechanisms that may form a water tight seal when fully engaged may include clip fasteners, gaskets, a screw type element, an o-ring element, slide and lock connection, or any other fastening structure that permits the end caps to be firmly attached to the main body 300 and forming a water tight seal.

Turning now to FIG. 4, consistent with certain embodiments of the invention is an exploded view of a main body and end portion connectors of a personal egg peeler consistent with certain embodiments of the present invention. In this exemplary view, the main body 400 of the personal egg peeler is a hollow structure that permits the insertion of one or more eggs into the hollow cavity forming the main body 400. Although the main body 400 is circular in cross section in this exemplary embodiment, this should in no way be considered limiting, as the main body 400 may be of any shape in cross section as long as the central portion of the main body has a cavity that accepts the insertion of one or more eggs in such as fashion as to permit the top end cap 402 and the bottom end cap 404 to be securely fastened to the main body 400 with the eggs fully inserted. The top end cap 402 and the bottom end cap 404 are configured to permit the end caps to be fastened to the top portion and the bottom portion of the main body 400, respectively, to form a water tight seal with the one or more eggs fully inserted into the main body 400.

Turning now to FIG. 5, consistent with certain embodiments of the invention is a flow diagram for the operation of a personal egg peeler consistent with certain embodiments of the present invention. In this exemplary embodiment, the action of peeling one or more eggs in the personal egg peeler begins at step 500 when a user removes an end cap, either the top portion or the bottom portion, of the personal egg peeler. At step 504, the user may place just one egg, or more than one egg, depending upon the size of the eggs relative to the hollow body section of the personal egg peeler. The user may only place the number of eggs into the personal egg peeler that will fit inside with sufficient clearance to permit the top of the personal egg peeler to be placed back into contact with the main body of the personal egg peeler so as to form a water tight seal, and will permit unrestrained movement of the egg, or eggs, inside the personal egg peeler.

At step 508, the user may add water to the main body of the personal egg peeler in sufficient quantity to fill a third of the interior of the main body, or sufficient water to rise to the indicator marking on the exterior surface of the main body of the personal egg peeler. At step 512, the user places the removed portion, whether the top portion or the bottom portion, of the personal egg peeler back into contact with the main body of the personal egg peeler. The placement of the removed portion of the egg peeler must be such that the top, or bottom, portion is in full contact along the entire extent of the gasket with the interior surface of the main body of the personal egg peeler, and put in place with sufficient force so as to form a water tight seal between the gasket part and the interior surface of the main body of the personal egg peeler.

At step 516, the user performs the egg peeling action by picking up the personal egg peeler and agitating the personal egg peeler in up and down, and circular motions for a pre-determined period of time. The pre-determined period of time may be approximately ten seconds, or may be adjusted based upon user experience or the number of eggs that have been inserted into the personal egg peeler to a greater or lesser extent to achieve a complete peeling action. At 520, the user, after agitating the personal egg peeler for the

6

pre-determined period of time, may remove the end cap portion of the personal egg peeler and pour out the separated egg and egg shell along with the water added earlier in the process. When completed, the top and bottom portions of the personal egg peeler may be removed to facilitate cleaning.

While certain illustrative embodiments have been described, it is evident that many alternatives, modifications, permutations and variations will become apparent to those skilled in the art in light of the foregoing description.

What is claimed is:

1. An egg peeler apparatus, comprising:
  - a container having a hollow main body and a top end cap and a bottom end cap;
  - the top end cap and bottom end cap having a convex shaped portion where said convex shaped portion is oriented such that the curved surface of each top and bottom end cap faces the interior of the cylindrical main body and forming the top and bottom portions of the container;
  - the interior surface of the container having a plurality of raised protrusions of sufficient height to extend into the hollow area of the hollow container;
  - the container main body having an internal dimension of sufficient diameter to permit the insertion of one or more standard size chicken eggs;
  - the apparatus configured to peel the one or more standard sized chicken eggs inserted into the hollow container when agitated by a user.
2. The apparatus of claim 1, where the main body of the container may have an external shape that is cylindrical, oval, square, rectangular, or any other regular shape.
3. The apparatus of claim 1, where the end caps form a water tight seal when securely fastened to the top and bottom portions of the main body of the container.
4. The apparatus of claim 1, where the raised protrusions are formed of the same material as the interior surface of the main body of the container.
5. The apparatus of claim 4, where the raised protrusions are shaped in an oval, rectangular, circular, square, or any other shape that is operative to form a protrusion against which an egg shell may impact.
6. The apparatus of claim 1, where the main body of the container is of sufficient dimension to be held in the hand of a user.
7. The apparatus of claim 1, where the top end cap and bottom end cap convex shape forms the center portion of the top end cap and bottom end cap, where the convex shape is of sufficient depth to permit a secure grip when held in the hand of the user.
8. The apparatus of claim 1, further comprising a fastening portion forming a portion of the top end cap and the bottom end cap where the fastening portion permits a user to remove the top end cap and the bottom end cap to remove any eggs and egg shells and to clean the interior of the main body of the container.
9. The apparatus of claim 1, where the interior volume of the main body of the container is sufficient to permit the insertion of as few as one or as many as three grade A large chicken eggs.
10. The apparatus of claim 1, where the agitation of the device is performed by the user for a predetermined time period of sufficient duration to crack and separate the shell from the egg or eggs inserted into the main body of the container.

\* \* \* \* \*

Complaint

EXHIBIT 4



# The Negg®

Hard-Boiled Egg Peeler

*Easy, Fast & Fun!*



The Negg

+ Follow

HOME

POSTS

Search all The Negg

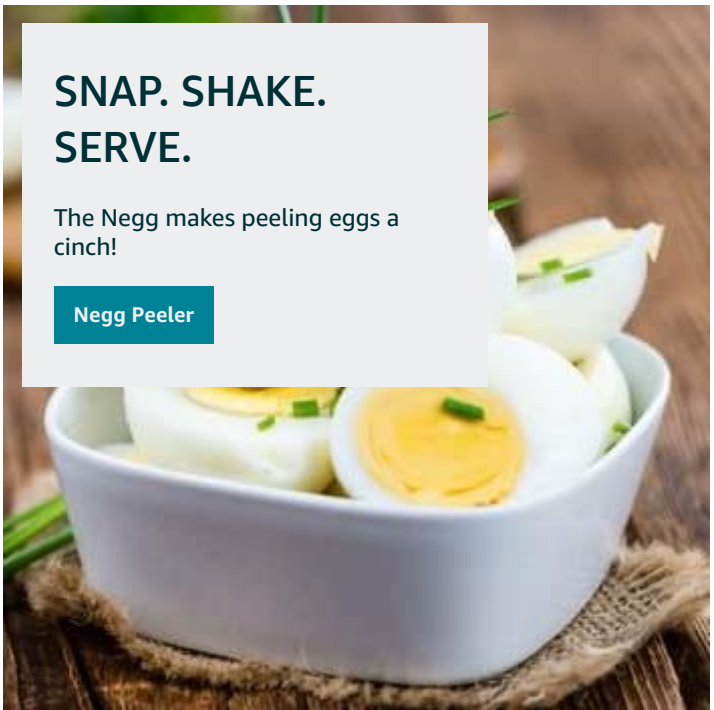

The Negg Boiled Egg Peeler  
Red

\$14<sup>95</sup>



The Negg Boiled Egg Peeler  
Yellow

\$14<sup>90</sup>

Only 11 left in stock - order soon.

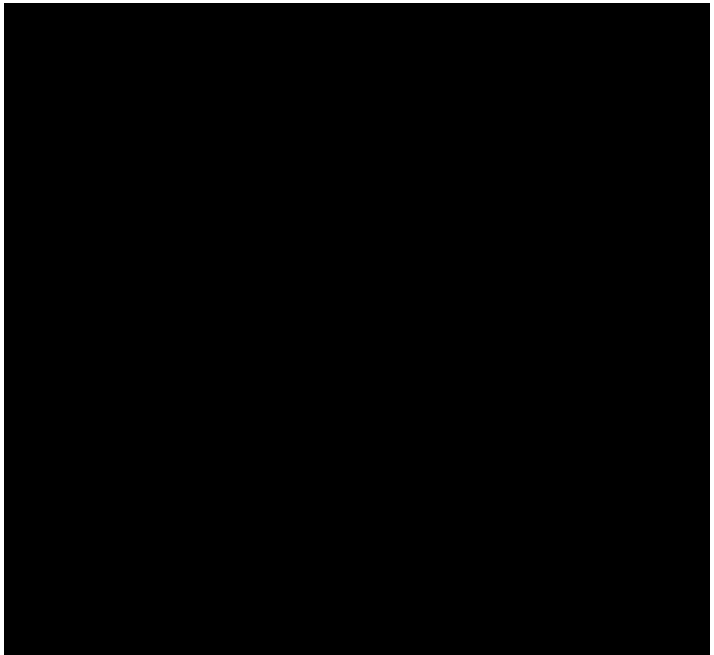

The Negg Boiled Egg Peeler  
Green

\$14.95 



The Negg Boiled Egg Peeler  
Blush Pink

Currently unavailable

The Negg Boiled Egg Peeler  
Fuchsia

\$14.95 



The Negg Boiled Egg Peeler  
White

\$14.95 



The Negg Boiled Egg Peeler  
Black

\$14.95 



Tired of gouged, pitted and mangled hard-boiled eggs? The Negg® makes peeling eggs as simple as a shake. Order your Negg® today, and enjoy easy and quick egg peeling in no time!

Share

# ALL PRODUCTS

Home > Egg Peelers

Filter:

Showing all 4 results

Best Selling

### Categories

- All Products 18
- Deviled Egg Kit 3
- DEVILED EGG SEASONI... 7
- Egg Peelers 4
- Kitchen Accessories & Bu... 2



NEGG EGG PRODUCTS  
**Negg® Egg Peeler Available in 7 Colors!**  
Hard-boiled eggs are back on the menu. Whether it's deviled eggs, eggs for garnish, or eggs for snacking, the Negg® egg peeler makes peeling your eggs easy, fast and fun. ...

\$14.95  
★★★★★



Chat with us <sup>1</sup>

Home > Egg Peelers

Filter:

Showing all 4 results

Best Selling

### Categories

- All Products 18
- Deviled Egg Kit 3
- DEVILED EGG SEASONI... 7
- Egg Peelers 4
- Kitchen Accessories & Bu... 2



NEGG EGG PRODUCTS  
**Negg® Egg Peeler Available in 7 Colors!**  
Hard-boiled eggs are back on the menu. Whether it's deviled eggs, eggs for garnish, or eggs for snacking, the Negg® egg peeler makes peeling your eggs easy, fast and fun. ...

\$14.95  
★★★★★



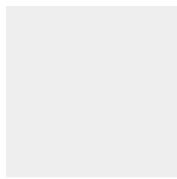

Negg® Egg Peeler Available in 7 Colors!  
\$14.95

- 1 +

ADD TO CART



Home > All Products > Negg® Egg Peeler Available...



### Negg® Egg Peeler Available In 7 Colors!

45 reviews

\$14.95

Hard-boiled eggs are back on the menu. Whether it's deviled eggs, eggs for garnish, or eggs for snacking, the Negg® egg peeler makes peeling your eggs easy, fast and fun. Place a little water in the Negg with your hard-boiled egg. Snap on the cap and give it a few shakes. The shell will separate from the egg leaving you with a perfectly peeled hard-boiled egg. Our guaranteed hard boiled egg peeler is the best way to peel a boiled egg. Stop the madness of peeling a hard boiled egg and become a Negghead – Let us help you "Get the Shell Outta Here!"

Color:

- 1 +

ADD TO CART

Chat with us <sup>1</sup>