

IN THE UNITED STATES DISTRICT COURT
FOR THE WESTERN DISTRICT OF PENNSYLVANIA

Michelle E. De Sousa,
Jose De Jesus De Sousa, and
BraNovations, Inc.

Plaintiffs,

v.

MOON BAY, A PURE LAND, AAA
OUTDOOR, ALADIN, ALISATWO, AMYS
LIFE, ANKES, ATINICOO, ATOM TAKES
YOU OVER THE MOUNTA,
AURORAEVOLVE, AWESOME SELECTION -
HAPPY LIFE GOOD GOODS GALLERY,
AWESOME SELECTION - LIHONG METAL
CONTAINER, BEAN CABIN, BEAUTYSTAR,
BEFASHIONCLUB, BEST BONNIE, BETAS
SHOP, BETHEL BOB, BOBI HOUSEHOLD
DAILY, BRACS, BYDONSUNG,
CCHENGSHOP, CHARM BOX, CHARM BOX
SELECT, CHEAPMRORE, CICCI,
COMFYPRO, CORNFIELD, COSY HOUSE
YOUR, CREATIVE ECLOTHING, CREIKUTA,
DANNISKKKYZJ, DAXUELLL, DEVELOP
SHOP, DEWENBANK, DONGLINGCHENG,
DUFLY, DUHEMICA,
ELEPHANTBOUTIQUE, EMBROIDERY
SHOP, ETCKKSS, FANLILLLLL, FEIHON
LOCAL, FEIXIANG ONE, FIRST, FODONG,
FOUR SEASONAL GOOD THINGS, FREE
THINKING FT, GABBY HOME, GAGABIRDS,
GIRL LINGERIE, GOOD LUCK YAJUN,
GREATTI, GUOJIANGJUN TWO, HANDSOME
JING HAO, HAPPINESS UNDERMN, HAPPY
LIFE GOOD GOODS GALLERY,
HHOMEESSENTIALS, HIBBDIAN, HOMOE,
HOTSALSHOP, HOUSE ROMANCE, HTG
FACTORY, HTG MFG, HTG SUPPLIERS,
HUAMALL, HUANGJIACONG, HUIYUAN

Case No.: 24 -cv-

COMPLAINT

FILED UNDER SEAL

DEMAND FOR JURY TRIAL

BOUTIQUE SHOP, HXDZ, IMPROVE OUR
QUALITY OF EXPRESS DELIVERY LIFE,
INTELLECTUAL CHILDHOOD,
JIAYUEBAIHUO, JIN AZURE STONE, JUDY
K, JUN T, JUNJUNLIQING, KELLYS CAKES,
KIIVMALL, KKITCHENWARE, KNNOWY,
KSPO, KUNYINGMAOYE, LAKING, LAO
LIUS TREASURE CHEST, LCONIC, LEEN
SHOP, LEOHK, LEOHKFIVE, LEOHKFOUR,
LEOHKTHREE, LERYEE, LIDO FIRE,
LONGSHAOXIAODIAN, LOVE LEATHER
BAG, LT TXDY, LU CHUN FISHING GEAR,
LUCAS LEU, LUCKY LADY MEIMEI,
LUXIAOER, MEIJIAJING HOME
FURNISHING, MEKAREN, ML GENERAL
SHOP, MMEGAMALL, MOMOBRAS, MORE
BEAUTIFUL CLOTHES, MOUNTAIN TOP Q,
NANCY STONE, NATURENESTS, NETEBUY,
NEW NUMBER ONE, NOEM, OILON,
ONLOVEEEEE, ONLYTU, OUR VARIOUS,
PEOPLE AND TROJANS, PHIPI SHOP, PICCI,
PLUS SIZE, PREFERABLY ZHEHENG,
PUREEHOME, Q Y FASHION, QAZ SUPPLY,
QUANCHEN BEST WISHES, REDXHY, RMM
FASHION, ROSE FLOWERS, RUKEEY,
SEMIASSIST SELECTIONS, SEXY
UNDERWEAR T, SEXYGIRLMM, SHENGYI
PREMIUM PRODUCTS, SHIJAKEJI,
SHOIFT, SHOPS ALONG THE STREET,
SHUNXIN YUEGOU, SMILEPLUS
ACCESSORIES, SONG YI WANG LUO
LOCAL, SUNH, SWEETIE UNDERPANTS,
SWQONE, TAOTAOSHOP, TENCOOL,
TIANTIANHUI, TING D, TINGS HOME, TOP
PERFECT MALL, TOPBOOC, TOPBOOC
TRAVELS LUGGAGE, TOUCHBRA FOU U,
TPAT SHOP, TTOMORROW, TUTU MAGIC
HOUSE, TUZHIFEI, UMI LIFE SHOP,

UNIFIEDD, VALLEY, VARIOUS OF SHOPS,
VENO, VIVIDVEIL, WANGGEY, WARM
HOME F, WE CAN DUN, WERR,
XIAOYAPIN, XUANSE, XYZ HOUSEHOLD
DAILY, YAN KANG, YAXIU UNDERWEAR,
YFF LINGERIE, YI XIAOMEI,
YINGQIUDIANZISHANGWU, YIY JIA,
YOCISIL, YOHOY, YOUNGGO, YOUR
SPEED, YUGAN SUPPLIES, ZHANGFIVE,
ZHANGSIX, ZHANGTHREE, ZHUANGLU,
ZM SOCKS, ZXZHANG, and ZZHAPPY
TRADING,

Defendants.

COMPLAINT FOR DAMAGES AND INJUNCTIVE RELIEF

Plaintiffs hereby sue Defendants, the Individuals, Partnerships, and Unincorporated Associations identified in the Caption, which are set forth in **Schedule “A”** hereto (collectively “Defendants”). All Defendants are knowingly and intentionally promoting, advertising, distributing, offering for sale, and selling patent infringing versions of Plaintiffs’ patented **CLEAVA®** and **SNAPPY CAMI®** brand mock camisoles, which infringe on one or more claims of the Plaintiffs’ Patent¹ and some of the Defendants and some are copying Plaintiffs’ photographs and advertising, throughout the United States, (“Plaintiffs’ Works”) (*as described below*) thus infringing on Plaintiffs’ copyright², using at least one of the Amazon.com,

¹ U.S. Patent No. 8,152,591, for a “GARMENT AND BRASSIERE ACCESSORY.” A copy of the patent is attached to the Complaint as **Exhibit 3**.

² While all of the Defendants are selling products that infringe on at least one claim of the Plaintiffs’ Patent, the following Defendants are using one or more of the Plaintiff’s photographs to advertise, market and sell their

eBay.com, Temu.com, Wish.com, Walmart.com, and Aliexpress.com online marketplaces (“Internet Marketplaces”) operating under the seller identities as set forth on **Schedule “A”** hereto (the “Seller IDs”)(“Infringing Product”). In support of its claims, Plaintiffs allege as follows:

NATURE OF THE ACTION

1. Michelle E. DeSousa is a co-inventor and owner and president of the Plaintiff company, BraNovations, Inc., the exclusive licensee of the Plaintiffs’ patented **CLEAVA®** and **SNAPPY CAMI®** brand mock camisoles, together with her husband and co-inventor, Jose De Jesus De Sousa, they are collectively the Plaintiffs bringing this lawsuit. Plaintiffs’ patented **CLEAVA®** and **SNAPPY CAMI®** brand mock camisoles are protected by multiple utility and design patents both here in the United States and Internationally.³ The Plaintiffs’ innovative mock camisoles are a garment and brassiere accessories that are worn under a top, easily adjusted for size, fasten to a brassiere, cover cleavage, and thus provide a user with the ability to wear short tops and dresses in situations that require modest attire.

Infringing Products and are thus unfairly competing: Comfypro, Dewenbank, FIRST ,Kkitchenware, MOMOBRAS, MOON BAY, NatureNests, Top Perfect Mall, VALLEY, and YaXiu Underwear.

³ U. S. A Utility Patents No.'s 8,062,093 and 8,152,591 and 8,257,139, U. S. A Design Patent No. D661,463 S, U. S. A. Registered Trademarks No.'s 3,784,662 and 3,950,573, Nigeria Utility Patent No. NG/C/1212/628, South Africa Utility Patent No. 2012/03020 and 2012/09413, Israel Utility Patent No. 218,817, Australia Utility Patent No. 2011253119, Mexico Utility Patent No. MX/a/2012/2012/003579, Mongolia Utility Patent No.3936, New Zealand Utility Patent No. NZ 599,573, Philippines Utility Patent No. 2012-500615, Algeria Utility Patent No. 120848, Japan Utility Patent No. 571 9489, Canada Utility Patent No. CA 2,812,384 / CA 2,812,530, CA 2,864,270, Singapore Utility Patent No. 185536, and Tunisia Utility Patent No. 23122.

2. All the Defendants have offered for sale, sold, and distributed knock-off versions of the Plaintiffs' Product which infringe at least one claim of the Plaintiffs' Patent. Moreover, Defendants' sale, distribution, and advertising of the Infringing Product are highly likely to cause consumers to believe that Defendants are offering a genuine version of Plaintiffs' Product when they are not.

3. Shown below are example types of Infringing Product offered for sale by the Defendants:



Plaintiffs' Listing



Infringing Listing of Defendant Comfypro



Plaintiffs' Listing



Infringing Listing of Defendant Dewenbank



Plaintiffs' Listing



Infringing Listing of Defendant First

Other Infringing Listings Appear in **Complaint Exhibit 1**.

4. Defendants' Infringing Products are not as well made and may disappoint consumers who may give bad reviews that may impact Plaintiffs' products.

5. Defendants' Infringing Products threaten to destroy the reputation of high quality that Plaintiffs' Products have earned.

6. Plaintiffs' Product is marketed and advertised extensively including on its website <https://www.cleava.com/> and its storefront on Amazon.com. The unique features of Plaintiffs' Product and the manner in which it is marketed and advertised, including the distinct photographs, the design, the instructions, the packaging, and the unique presentation of the product, all comprise Plaintiffs' valuable intellectual property ("IP") and all have become distinct in consumer's minds such that consumers associate all of this IP with Plaintiffs' Product. Screenshots from Plaintiffs' Website and Amazon Store are attached as **Complaint Exhibit 2**.

7. The innovative features of Plaintiffs' Product are the subject of U. S. Patent No. 8,152,591 entitled "GARMENT AND BRASSIERE ACCESSORY." A copy of the patent is attached as **Complaint Exhibit 3**. The Plaintiffs' Product is marked in accordance with the

Patent Act. A Claim Chart for an exemplar infringing product is attached as **Complaint Exhibit 4** demonstrating that the Defendant's products infringe on at least Claim 1 of the Plaintiffs' Patent.

8. On information and belief, Defendants' sale of Infringing Products gives rise to a plausible expectation that discovery will reveal that Defendants' actions all arise from the same transaction, occurrence, or series of transactions. Specifically, on information and belief, Defendants are actively participating in a conspiracy to distribute and sell Infringing Products. For example, Defendants, on information and belief, are working together to manufacture, arrange the manufacture of and/or sell and otherwise distribute the Infringing Products. Moreover, the Infringing Products all infringe on at least one claim of the Plaintiffs' Patent.

9. Plaintiffs therefore bring this action for Patent Infringement under 35 U.S.C. § 271, and The All-Writs Act, 28 U.S.C. § 1651(a) and against some of the Defendant under Section 43 (a) of the Lanham Act.

JURISDICTION AND VENUE

10. This Court has subject matter jurisdiction over this action pursuant to 15 U.S.C. § 1121, 28 U.S.C. §§ 1331 and 1338. This Court has supplemental jurisdiction pursuant to 28 U.S.C. § 1367 over Plaintiffs' state law claims because those claims are so related to the federal claims that they form part of the same case or controversy.

11. This Court may exercise personal jurisdiction over a non-resident of the State in which the Court sits to the extent authorized by the state's laws. Fed. R. Civ. P. 4(e). Pennsylvania authorizes personal jurisdiction over each Defendant pursuant to 42 Pa. Cons. Stat.

§ 5322 (a) which provides in pertinent part: “A tribunal of this Commonwealth may exercise personal jurisdiction over a person ... as to a cause of action or other matter arising from such person: (1) Transacting any business in this Commonwealth. Without excluding other acts which may constitute transacting business for the purpose of this paragraph: (ii) The doing of a single act in this Commonwealth for the purpose of thereby realizing pecuniary benefit ... (3) Causing harm or tortious injury by an act or omission in this Commonwealth. (4) Causing harm or tortious injury by an act or omission outside this Commonwealth ... (10) Committing any violation within the jurisdiction of the Commonwealth of any statute, home rule charter, local ordinance or resolution, or rule or regulation promulgated thereunder by any government unit or of any order of court or other government unit.” In the alternative, Federal Rule of Civil Procedure 4(k) confers personal jurisdiction over the Defendants because, upon information and belief, Defendants regularly conduct, transact and/or solicit business in Pennsylvania and in this judicial district, and/or derive substantial revenue from their business transactions in Pennsylvania and in this judicial district and/or otherwise avail themselves of the privileges and protections of the laws of the Commonwealth of Pennsylvania such that this Court's assertion of jurisdiction over Defendants does not offend traditional notions of fair play and due process, and/or Defendants' illegal counterfeiting and infringing actions caused injury to Plaintiffs in Pennsylvania and in this judicial district such that Defendants should reasonably expect such actions to have consequences in Pennsylvania and in this judicial district, for example:

a. Upon information and belief, at all times relevant hereto, Defendants were and/or are systematically directing and/or targeting their business activities at consumers in the United States, including Pennsylvania, through on-line platforms with Merchant

Storefronts (as defined *infra*), via on-line marketplace websites, such as Amazon.com, under the Seller IDs, as well as any and all as yet undiscovered accounts with Merchant Storefronts held by or associated with Defendants, their respective officers, employees, agents, servants and all persons in active concert or participation with any of them (“User Accounts”), through which consumers in the United States, including Pennsylvania, can view the one or more of Defendants’ Merchant Storefronts that each Defendant operates, uses to communicate with Defendants regarding their listings for Infringing Products and to place orders for, receive invoices for and purchase Infringing Products for delivery in the U.S., including Pennsylvania, as a means for establishing regular business with the U.S., including Pennsylvania.

b. Upon information and belief, certain Defendants are sophisticated sellers, each operating one or more commercial businesses using their respective User Accounts through which Defendants, their respective officers, employees, agents, servants and all persons in active concert of participation with any of them, operate storefronts to manufacture, import, export, advertise, market, promote, distribute, offer for sale and/or otherwise deal in products, including the Infringing Products, which are held by or associated with Defendants, their respective officers, employees, agents, servants and all persons in active concert or participation with any of them (“Merchant Storefront(s)”) in wholesale quantities at significantly below-market prices to consumers worldwide, including to those in the U.S., and specifically Pennsylvania.

c. Upon information and belief, Defendants' Merchant Storefronts reflect multiple sales to consumers all over the world, including repeat sales to consumers in the U.S. and into this judicial district.

d. Upon information and belief, all Defendants accept payment in U.S. Dollars and offer shipping to the U.S., including to Pennsylvania.

e. Upon information and belief, at all times relevant, Defendants have transacted business with consumers located in the U.S., including Pennsylvania, for the sale and shipment of Infringing Products.

f. Upon information and belief, some Defendants are employing and benefiting from substantially similar, paid advertising and marketing and advertising strategies in order to make their Merchant Storefronts selling illegal goods appear more relevant and attractive to search result software across an array of search words, including but not limited to "CLEAVA" and "SNAPPY CAMI". By their actions, Defendants are causing concurrent and indivisible harm to Plaintiffs and the consuming public by (i) depriving Plaintiffs of their right to fairly compete for space within the various on-line marketplace search results and reducing the visibility of the Plaintiffs' Product on various on-line marketplaces and/or diluting and driving down the retail market price for the Plaintiffs' Product; (ii) causing an overall degradation of the value of the goodwill associated with Plaintiffs' Product; and (iii) increasing Plaintiffs' overall cost to market its goods and educate consumers about its brand and products.

g. Upon information and belief, Defendants have cooperated, communicated their plans with one another, shared information, and coordinated their efforts, all in order to create an illegal marketplace operating in parallel to the legitimate marketplace of Plaintiffs' and the legally authorized resellers of Plaintiffs' genuine goods.

h. Upon information and belief, Defendants are concurrently targeting their infringing activities toward consumers and causing harm in Allegheny County, Pennsylvania.

i. Upon information and belief, Defendants likely reside and/or operate in foreign jurisdictions with lax trademark and patent enforcement systems and are cooperating by creating an illegal stream of infringing and counterfeit goods.

j. Upon information and belief, Defendants are aware of Plaintiffs, their genuine **CLEAVA®** and **SNAPPY CAMI®** mock camisole products, and are aware that their illegal infringing actions alleged herein are likely to cause injury to Plaintiffs in the United States, in Pennsylvania and in this judicial district specifically, as Plaintiffs conduct substantial business in Pennsylvania.

k. Plaintiffs are suffering irreparable and indivisible injury and suffered substantial damages as a result of Defendants' unauthorized and wrongful sale of infringing goods.

12. Venue is proper, *inter alia*, pursuant to 28 U.S.C. § 1391 because, for example:

a. Upon information and belief, Defendants conduct, transact, and/or solicit business in this judicial district.

b. Upon information and belief, Defendants or their agent(s) may be found in this district because personal jurisdiction is proper in this district.

c. Upon information and belief, this is a judicial district in which a substantial part of the events or omissions giving rise to the infringement claims occurred, or a substantial part of the property that is the subject of the action is situated.

d. Defendants not resident in the United States may be sued in this judicial district because personal jurisdiction is proper in this district.

THE PLAINTIFFS

13. Plaintiff company, BraNovations, Inc. d/b/a Cleava, is a Florida corporation and has its principal place of business in Naples Florida. Plaintiffs, Michelle E. De Sousa and Jose De Jesus De Sousa, are co-inventors and owners of the Plaintiffs' Patent. BraNovations, Inc. is the exclusive licensee of the Plaintiffs' Patent.

14. Plaintiffs are, in part, engaged in the business of manufacturing and distributing throughout the world, including within this district, the **CLEAVA**[®] and **SNAPPY CAMI**[®] mock camisole products, through their website, cleava.com, its authorized storefront on amazon.com, and various retail establishments. Defendants, through the sale and offer to sell Infringing Products are directly, and unfairly, competing with Plaintiffs' economic interest in the Commonwealth of Pennsylvania and causing Plaintiffs harm within this jurisdiction.

15. Like many other brand owners, Plaintiffs suffer ongoing daily and sustained violations of their rights at the hands of infringers, such as Defendants herein, who wrongfully reproduce Plaintiffs' Products for the twin purposes of (i) duping and confusing the consuming

public and (ii) earning substantial profits from the sale of their Infringing Products. The natural and intended byproduct of Defendants' actions is the erosion and destruction of the goodwill associated with Plaintiffs' Products and the destruction of the legitimate market sector in which Plaintiffs operate.

16. The recent explosion of counterfeiting and infringement over the Internet, including through online marketplace platforms, has created an environment that requires brand owners, such as Plaintiffs, to expend significant time and money across a wide spectrum of efforts in order to protect both consumers and Plaintiffs from the ill effects of confusion and the erosion of the goodwill associated with Plaintiffs' brand and products.

17. E-commerce sales, including through e-commerce stores like those of Defendants, have resulted in a sharp increase in the shipment of unauthorized products into the United States. *Ference Dec⁴*, Exhibit 1, Excerpts from Fiscal Year 2021 U.S. Customs and Border Protection ("CBP") Intellectual Property Seizure Statistics Report. Over 89% of all CBP intellectual property seizures were smaller international mail and express shipments (as opposed to large shipping containers). *Id.* More than half (51%) of CBP seizures originated from mainland China and Hong Kong. *Id.* Infringing and pirated products account for billions in economic losses, resulting in tens of thousands of lost jobs for legitimate businesses and broader economic losses, including lost tax revenue.

⁴ Referring to Declaration of Stanley D. Ference III in Support of Temporary Restraining Order, filed herewith.

18. Third party service providers like those used by Defendants do not adequately subject new sellers to verification and confirmation of their identities, allowing infringers to “routinely use false or inaccurate names and addresses when registering with these e-commerce platforms.” *Ference Dec.*, Exhibit 2, Daniel C.K. Chow, Alibaba, Amazon, and Infringing in the Age of the Internet, 40 NW. J. INT’L L. & BUS. 157, 186 (2020); see also, report on “Combating Trafficking in Infringing and Pirated Goods” prepared by the U.S. Department of Homeland Security’s Office of Strategy, Policy, and Plans (Jan. 24, 2020), attached as *Ference Dec.*, Exhibit 3 and finding that on “at least some e-commerce platforms, little identifying information is necessary for an Infringer to begin selling” and recommending that “[s]ignificantly enhanced vetting of third-party sellers” is necessary. Infringers hedge against the risk of being caught and having their websites taken down from an e-commerce platform by preemptively establishing multiple virtual store-fronts. *Ference Dec.*, Exhibit 3, at p. 22. Since platforms generally do not require a seller on a third-party marketplace to identify the underlying business entity, Infringers can have many different profiles that can appear unrelated even though they are commonly owned and operated. *Ference Dec.*, Exhibit 3 at p. 39. Further, “E-commerce platforms create bureaucratic or technical hurdles in helping brand owners to locate or identify sources of Infringing and Infringers.” *Ference Dec.*, Exhibit 2 at 186-187.

THE DEFENDANTS

19. The Defendants are individuals and/or business entities of unknown makeup, each of whom, upon information and belief, either reside or operate in foreign jurisdictions, or (though

not foreign)⁵ redistribute products from the same or similar sources in those foreign locations. Defendants have the capacity to be sued pursuant to Federal Rule of Civil Procedure 17(b). Defendants target their business activities toward consumers throughout the United States, including within this district, and conduct pervasive business through the operation of, at least, one fully interactive commercial Internet based e-commerce store via, at least one of the Internet based online marketplaces Aliexpress.com, Amazon.com, eBay.com, Temu, Walmart.com, and Wish.com, all under the Seller IDs.

20. Upon information and belief, the Defendants use aliases in conjunction with the operation of their businesses as set forth in Schedule “A” hereto.

21. Defendants are the past and present controlling forces behind the sale of products infringing at least one claim of the Plaintiffs’ Patent described herein using at least the Seller IDs.

22. Upon information and belief, Defendants were willfully advertising, offering for sale and selling goods infringing upon at least one claim of the Plaintiffs’ Patent to consumers within the United States and this district through several fully interactive, commercial Internet websites and Internet based e-commerce stores operating under, at least, the storefronts, the Seller IDs, and any additional domain names, websites and corresponding website URLs or seller

⁵ Prior to filing this lawsuit, Plaintiffs viewed a public seller profile that is published by certain Defendant’s storefronts that purports to identify the name and address of the Defendant. Solely based upon their representation on their storefronts, the following defendants have identified themselves as US-based and are not at this time alleged to be foreign sellers: MOON BAY, FIRST, CREIKUTA, Free Thinking FT, and SemiAssist Selections.

identifications and store URL aliases not yet known to Plaintiffs. Defendants have purposefully directed some portion of their illegal activities towards consumers in the Commonwealth of Pennsylvania through the advertisement, offer to sell, sale, and/or shipment of Infringing Products into the Commonwealth.

23. Defendants have registered, established, or purchased, and maintained the on-line marketplace website storefronts and Seller IDs. Upon information and belief, Defendants have engaged in fraudulent conduct with respect to the registration of the storefronts and Seller IDs by providing false and/or misleading information to the Internet based e-commerce platforms where they offer for sale and/or sell, during the registration or maintenance process related to their respective Seller ID. Upon information and belief, Defendants have anonymously registered and maintained some of the Seller IDs for the sole purpose of engaging in illegal infringing activities.

24. Upon information and belief, Defendants will continue to register or acquire new seller identification aliases for the purpose of selling and offering for sale goods infringing at least one claim of the Plaintiffs' Patent unless preliminarily and permanently enjoined.

25. Defendants' Internet-based businesses amount to nothing more than illegal operations established and operated in order to infringe the intellectual property rights of Plaintiffs.

26. Defendants' business names, i.e., the Seller IDs, associated payment accounts, and any other alias seller identification names used in connection with the sale of goods infringing on at least one claim of the Plaintiffs' Patent are essential components of Defendants' online

activities and are the means by which Defendants further their infringement scheme and cause harm to Plaintiff.

COMMON FACTUAL ALLEGATIONS

Plaintiffs and Their Innovative Product

27. The Plaintiffs' Product is designed to quickly attach to a brassiere, adjust to the correct size, convert a short top or dress into a modest manner of dress. The Plaintiffs' Product retails for between \$19.99 and \$39.99 (pictured below):



28. The Plaintiffs' Patent has never been assigned or licensed to any of the Defendants in this matter. Plaintiffs have provided constructive notice of the Plaintiffs' Patent by placing the patent number of the patent on the packaging of Plaintiffs' Product.

29. Plaintiffs' Product has been featured in videos or articles by numerous media outlets.

Defendants' Wrongful and Infringing Conduct

30. Upon information and belief, Defendants are, through at least the Internet based e-commerce stores operating under the Seller IDs, promoting, selling, offering for sale, and distributing goods that willfully infringe at least one claim of the Plaintiffs' Patent while marketing their knock-off products in a willful attempt to pass off their knock-off products as the genuine version of Plaintiffs' Products.

31. Upon information and belief, Defendants' Infringing Products are of a quality substantially and materially different than that of Plaintiffs' genuine goods. Defendants, upon information and belief, are actively using, promoting and otherwise advertising, distributing, selling, and/or offering for sale substantial quantities of their Infringing Products with the knowledge and intent that such goods will be mistaken for the genuine high-quality goods offered for sale by Plaintiffs despite Defendants' knowledge that they are without authority to use the subject matter of the Plaintiffs' Patent.

32. Defendants advertise their Infringing Products for sale to the consuming public via Internet based e-commerce stores on, at least, one Internet marketplace using at least the Seller IDs. In so advertising these goods, Defendants improperly and unlawfully infringe at least one claim of the Plaintiffs' Patent without Plaintiffs' permission.

33. As part of their overall infringement scheme, Defendants are, upon information and belief, concurrently employing and benefitting from substantially similar, advertising and marketing strategies based, in large measure, upon an illegal use of infringements of the

Plaintiffs' Patent in order to make their e-commerce stores selling illegal goods appear more relevant and attractive to consumers online. By their actions, Defendants are contributing to the creation and maintenance of an illegal marketplace operating in parallel to the legitimate marketplace for Plaintiffs' genuine goods. Defendants are causing, individual, concurrent and indivisible harm to Plaintiffs and the consuming public by (i) depriving Plaintiffs and other third parties of their right to fairly compete for space within search engine results and reducing the visibility of Plaintiffs' genuine goods on the World Wide Web, (ii) causing actual consumer confusion, (iii) harm to Plaintiffs' reputations, including tarnishing their status as the innovator in this market, (iv) an overall degradation of the value of the goodwill associated with the Plaintiffs' brand, and (v) increasing Plaintiffs' overall cost to market its goods and educate consumers about its brand via the Internet.

34. Plaintiffs confirmed that Defendants were and/or are still currently offering for sale and/or selling Infringing Products for sale to the consuming public via Internet based e-commerce stores on, at least, one Internet marketplace using at least the Seller IDs and that Defendants provide shipping and/or have actually shipped Infringing Products to customers located within this judicial district.

35. There is no question that the Infringing Product itself and the manner in which it is marketed is designed to confuse and mislead consumers into believing that they are purchasing Plaintiffs' Product or that the Infringing Product is otherwise approved by or sourced from Plaintiffs, thereby trading on the goodwill and reputation of Plaintiffs.

36. Upon information and belief, at all times relevant hereto, Defendants in this action had full knowledge of Plaintiffs' ownership of the Plaintiffs' Patent. Defendants' use of the patent is without Plaintiffs' consent or authorization.

37. Defendants are engaging in the above-described illegal infringing activities knowingly and intentionally or with reckless disregard or willful blindness to Plaintiffs' rights for the purpose of infringing the Plaintiffs' Patent and trading on Plaintiffs' goodwill and reputation. If Defendants' intentional infringing activities are not preliminarily and permanently enjoined by this Court, Plaintiffs and the consuming public will continue to be harmed.

38. Defendants above identified infringing activities are likely to cause confusion, deception, and mistake in the minds of consumers before, during, and after the time of purchase. Moreover, Defendants' wrongful conduct is likely to create a false impression and deceive customers, the public, and the trade into believing there is a connection or association between Plaintiffs' Products and Defendants' Infringing Products, which there is not.

39. Upon information and belief, Defendants' payment and financial accounts are being used by Defendants to accept, receive, and deposit profits from Defendants' infringing activities connected to their Seller IDs and any other alias e-commerce stores, photo albums, seller identification names, domain names, or websites being used and/or controlled by them.

40. Further, upon information and belief, Defendants are likely to transfer or secret their assets to avoid payment of any monetary judgment awarded to Plaintiffs.

41. Plaintiffs have no adequate remedy at law.

42. Plaintiffs are suffering irreparable injury and have suffered substantial damages as a result of Defendants' unauthorized and wrongful infringement of at least one claim of the Plaintiffs' Patent. If Defendants' infringing activities are not preliminarily and permanently enjoined by this Court, Plaintiffs and the consuming public will continue to be harmed.

43. The harm and damages sustained by Plaintiffs have been directly and proximately caused by Defendants' wrongful reproduction, use, advertisement, promotion, offers to sell, and sale of their Infringing Products.

COUNT I – PATENT INFRINGEMENT (35 U.S.C. § 271 (a))

44. The allegations in the above paragraphs are hereby incorporated by reference.

45. The innovative features of Plaintiffs' Product are the subject of U. S. Patent No. 8,152,591 entitled "GARMENT AND BRASSIERE ACCESSORY" (a copy of the patent is attached to the Complaint as **Exhibit 3**). The Plaintiffs' Product is marked in accordance with the Patent Act.

46. The Infringing Products infringe at least Claim 1 of the Plaintiffs' Product, as more fully detailed in **Exhibit 3 and Exhibit 4**, respectively.

47. Defendants have infringed and continue to infringe the Plaintiffs' Patent either directly or indirectly through acts of contributory infringement or inducement in violation of 35 U.S.C. § 271, by making, using, selling, importing and/or offering to sell Infringing Products, namely the knock-offs that infringe at least one claim of the Plaintiffs' Patent.

48. Defendants' infringement, contributory infringement and/or inducement to infringe has injured Plaintiffs and they, therefore, are entitled to recover damages adequate to compensate it for such infringement, but in no event less than a reasonable royalty.

49. Defendants' infringement, contributory infringement and/or inducement to infringe has been willful and deliberate because Defendants have notice of or knew of the Plaintiffs' Patent and have nonetheless injured and will continue to injure Plaintiffs, unless and until this Court enters an injunction, which prohibits further infringement and specifically enjoins further manufacture, use, sale, importation and/or offer for sale of products or services that come within the scope of the Plaintiffs' Patent.

50. Based on Defendants' wrongful conduct, Plaintiffs are entitled to injunctive relief as well as monetary damages and other remedies as provided by the Patent Act, including damages that Plaintiffs have sustained and will sustain as a result of Defendants' illegal and infringing actions as alleged herein, enhanced discretionary damages and reasonable attorneys' fees and costs.

COUNT II – FEDERAL UNFAIR COMPETITION (15 U.S.C. § 1125(a))

Plaintiffs vs. Defendant Nos. 1, 27, 35, 45, 79, 104, 108, 147, 157, 169 ⁶

51. Plaintiffs hereby adopt and re-allege the allegations set forth in the preceding paragraphs as if set forth herein.

⁶ See note 2, *supra*.

52. Upon information and belief, Defendants' Infringing Products bearing, offered for sale, and sold using copies of at least one of the Plaintiffs' Works have been widely advertised and offered for sale throughout the United States via at least one fully interactive Internet marketplace.

53. Defendants' Infringing Products bearing, offered for sale, and sold using copies of at least one of the Plaintiffs' Works are virtually identical in appearance to Plaintiffs' genuine goods. Defendants' Infringing Products, however, are different and likely inferior in quality. Accordingly, Defendants' activities are likely to cause confusion in market and among the general public as to at least the origin or sponsorship of their Infringing Products.

54. Defendants, upon information and belief, have used in connection with their advertisement, offer for sale, and sale of their Infringing Products, false designations of origin and false descriptions and representations, including words or other symbols and trade dress, which tend to falsely describe or represent such goods and have caused such goods to enter into with full knowledge of the falsity of such designations of origin and such descriptions and representations, all to Plaintiffs' detriment.

55. Defendants have engaged in the unauthorized use of Plaintiffs' Works in Defendants' advertisement and promotion of their Infringing Products. Defendants have misrepresented to members of the consuming public that the Infringing Products being advertised and sold by them are genuine, non-infringing goods.

56. Additionally, Defendants are using infringements of the Plaintiffs' Works in order to unfairly compete with Plaintiffs and others for space within search engine organic results,

thereby jointly depriving Plaintiffs of a valuable marketing and educational tool which would otherwise be available to Plaintiffs and reducing the visibility of Plaintiffs' genuine goods on the World Wide Web.

57. Defendants' above-described actions are in violation of Section 43(a) of the Lanham Act, 15 U.S.C. § 1125(a).

58. Plaintiffs have no adequate remedy at law, and have sustained indivisible injury and damage caused by Defendants' concurrent conduct. Absent an entry of an injunction by this Court, Defendants will continue to wrongfully reap profits and Plaintiffs will continue to suffer irreparable injury to its goodwill and business reputation, as well as monetary damages.

59. Based on Defendants' wrongful conduct, Plaintiffs are entitled to injunctive relief, Plaintiffs' actual damages and Defendants' profits in an amount to be proven at trial, enhanced discretionary damages for willful infringement, and reasonable attorneys' fees and costs.

Count III – Common Law Unfair Competition

Plaintiffs vs. Defendant Nos. 1, 27, 35, 45, 79, 104, 108, 147, 157, 169

60. Plaintiffs hereby adopt and re-allege the allegations set forth in the preceding paragraphs as if set forth herein.

61. This is an action against Defendants based on their promotion, advertisement, distribution, sale, and/or offering for sale of goods bearing and/or using marks that are virtually identical, both visually and phonetically, to one or more of the Plaintiffs' Works in violation of Pennsylvania's common law of unfair competition.

62. Specifically, Defendants are promoting and otherwise advertising, selling, offering for sale, and distributing goods bearing and/or using infringements of one or more of the Plaintiffs' Works. Defendants are also using infringements of one or more of the Plaintiffs' Works to unfairly compete with Plaintiffs and others on Internet marketplaces, for space in search results across an array of search terms, and visibility on the World Wide Web.

63. Defendants' infringing activities are likely to cause and actually are causing confusion, mistake, and deception among members of the trade and the general consuming public as to the origin and quality of Defendants' products by their use of one or more of the Plaintiffs' Works.

64. Plaintiffs have no adequate remedy at law and are suffering irreparable injury and damages as a result of Defendants' actions.

65. As a result of Defendants' actions alleged herein, Plaintiffs are entitled to injunctive relief, an order granting Plaintiffs' damages and Defendants' profits stemming from their infringing activities, and exemplary or punitive damages for Defendants' intentional misconduct.

PRAYER FOR RELIEF

WHEREFORE, Plaintiffs demand judgment on all Counts of this Complaint and an award of equitable relief and monetary relief against Defendants as follows:

a. Entry of temporary, preliminary, and permanent injunctions pursuant to 35 U.S.C. § 283, and Federal Rule of Civil Procedure 65 enjoining Defendants, their agents, representatives, servants, employees, and all those acting in concert or participation therewith, from manufacturing or causing to be manufactured, importing, advertising or promoting, distributing,

selling or offering to sell their Infringing Products (i.e., patent infringing or unfairly competing by using copies or unauthorized derivative works of Plaintiffs' Works);

c. Entry of an Order that, upon Plaintiffs' request, any Internet marketplace website operators and/or administrators that are provided with notice of the injunction, including but not limited to the online marketplaces Aliexpress.com, Amazon.com, ebay.com, Temu.com, Walmart.com and wish.com, identify any e-mail address known to be associated with Defendants' respective Seller ID, and cease facilitating access to any or all e-commerce stores through which Defendants engage in the promotion, offering for sale, and/or sale of Infringing Products.

d. Entry of an Order that, upon Plaintiffs' request, any Internet marketplace website operators and/or administrators who are provided with notice of the injunction, including but not limited to the online marketplaces Aliexpress.com, Amazon.com, ebay.com, Temu.com, Walmart.com and wish.com, permanently remove any and all listings offering for sale Infringing Products via the e-commerce stores operating under the Seller IDs, including any and all listings linked to the same seller or linked to any other alias seller identification name being used and/or controlled by Defendants to promote, offer for sale and/or sell Infringing Products.

e. Entry of an Order that, upon Plaintiffs' request, any Internet marketplace website operators and/or administrators who are provided with notice of the injunction, including but not limited to the online marketplaces Aliexpress.com, Amazon.com, ebay.com, Temu.com, Walmart.com and wish.com, immediately cease fulfillment of and sequester all goods of each

Defendant or other Seller under a Seller ID offering for sale the Infringing Product in its inventory, possession, custody, or control, and surrender those goods to Plaintiffs.

f. Entry of an order awarding Plaintiffs damages adequate to compensate for the infringement of its patent, but in no event less than a reasonable royalty for the use made of the invention by the Defendants, together with interest and costs as fixed by the Court pursuant to 35 U.S.C. § 284 and that the award be trebled as provided for under 35 U.S.C. §284.

g. Entry of an order requiring Defendants to account to and pay Plaintiffs for all profits and damages resulting from Defendants' infringing and unfairly competitive activities and that the award to Plaintiffs be trebled, as provided for under 15 U.S.C. §1117.

h. Entry of an award pursuant to 15 U.S.C. § 1117 (a) and (b) of Plaintiffs' costs and reasonable attorneys' fees and investigative fees associated with bringing this action.

i. Entry of an Order finding that this case is exceptional and an award to Plaintiffs of its attorney fees and costs as provided by for under 35 U.S.C. § 285.

j. Entry of an Order that, upon Plaintiffs' request, any financial institutions, payment processors, banks, escrow services, money transmitters, including, but not limited to, Amazon Services, LLC d/b/a Amazon.com, and Amazon Payments, Inc. d/b/a Amazon Pay (collectively "Amazon"), Whaleco Inc., a Delaware Corporation, which is a wholly owned subsidiary of Pinduoduo Inc. which is owned by PDD Holdings (collectively, "Temu"), eBay, Inc. d/b/a ebay.com, Walmart Inc. and Wal-Mart.com USA, LLC, wish.com, Alibaba.com US LLC d/b/a Alibaba.com and Aliexpress.com ("Third Party Service Providers") and financial institutions, including but not limited to, Zhejiang Ant Small and Micro Financial Services Group Co., Ltd.

AliPay (China) Internet Technology Co. Ltd., and Alipay.com Co., Ltd. (collectively referred to as “AliPay”)⁷, Amazon Payments, Inc., Walmart Pay, Klarna, Inc. d/b/a Klarna, PayPal, Inc. d/b/a paypal.com, and Context Logic, Inc. d/b/a wish.com (“Financial Institutions”)⁸, and their related companies and affiliates, identify and restrain all funds, up to and including the total amount of judgment, in all financial accounts and/or sub-accounts used in connection with the Seller IDs or other domain names, alias seller identification names, or e-commerce store names or store URLs used by Defendants presently or in the future, as well as any other related accounts of the same customer(s) and any other accounts which transfer funds into the same financial institution account(s), to be surrendered to Plaintiffs in partial satisfaction of the monetary judgment entered herein.

k. Entry of an award of pre- and post-judgment interest on the judgment amount.

l. Entry of an order for any further relief as the Court may deem just and proper.

⁷ WorldPay US, Inc. (“WorldPay”) processes transactions on behalf of Alibaba and Alipay, which may appear as “Aliexpress” on a cardholder’s credit card statement.

⁸ Plaintiffs acknowledge that they are seeking multiple forms of relief. Plaintiffs will promptly provide supplemental briefing or oral argument on any issue should the Court request it.

DEMAND FOR JURY TRIAL

Plaintiffs respectfully demand a trial by jury on all claims.

Respectfully submitted,

Dated: November 12, 2024

/s/ Stanley D. Ference III

Stanley D. Ference III

Pa. ID No. 59899

courts@ferencelaw.com

Brian Samuel Malkin

Pa. ID No. 70448

bmalkin@ferencelaw.com

FERENCE & ASSOCIATES LLC

409 Broad Street

Pittsburgh, Pennsylvania 15143

(412) 741-8400 - Telephone

(412) 741-9292 - Facsimile

Attorneys for Plaintiffs

Schedule “A”
Defendants with Store Name and Seller ID

Defendant Number	Store/Seller Name	Seller ID
1	MOON BAY	635517727758482
2	A pure land	634418212896294
3	AAA Outdoor	634418210875963
4	Aladin	5528254826496
5	AlisaTwo	634418215794109
6	AMYS Life	634418214539327
7	Ankes	634418212388126
8	ATinicoo	634418217714778
9	Atom takes you over the mounta	634418215517217
10	Auroraevolve	634418217037058
11	Awesome Selection - Happy life good goods gallery	415511530677
12	Awesome Selection - Lihong metal container	1780876881588
13	Bean cabin	634418211354660
14	Beautystar	634418210888924
15	BEfashionclub	5756385642743
16	Best Bonnie	6115905219145
17	Betas shop	5549403515591
18	Bethel Bob	634418212399765
19	Bobo Household Daily	634418217213332
20	BRACS	634418214437748
21	BYDONSUNG	634418212130543
22	CChengShop	2728460554941
23	Charm Box	634418215748991
24	Charm Box Select	634418217402649
25	cheapmore	634418218281109
26	Cicci	116182969267
27	Comfypro	634418216916963
28	cornfield	39583751921
29	Cosy house your	634418215126855
30	Creative eclthing	634418210141977

Defendant Number	Store/Seller Name	Seller ID
31	CREIKUTA	635517728206080
32	DanniskkyZJ	634418211202110
33	DAXUELLL	634418217205855
34	develop shop	634418210798266
35	Dewenbank	634418216890430
36	Donglingcheng	634418217703871
37	Dufly	634418217558511
38	DUHEMICA	634418215962368
39	ELEPHANTBOUTIQUE	634418212856234
40	Embroidery Shop	634418211775007
41	ETCKKSS	634418211765865
42	fanlillll	634418215829711
43	Feihon local	634418216977483
44	FeiXiang one	634418211723611
45	FIRST	635517727287493
46	FODONG	634418213589058
47	Four Seasonal Good Things	634418212707863
48	Free thinking FT	635517728960900
49	GABBY HOME	634418212988835
50	gagabirds	634418216428344
51	Girl Lingerie	634418218456067
52	Good Luck Yajun	634418211144208
53	GREATTI	634418217316775
54	Guojiangjuntwo	634418218093108
55	Handsome Jing Hao	634418214759750
56	Happiness Undermn	634418218143802
57	Happy life good goods gallery	241101709208
58	HHomeEssentials	634418217371905
59	Hibbdian	634418217080958
60	Homoe	634418213537582
61	Hotsaleshop	634418217709738
62	House Romance	634418212117144
63	HTG Factory	634418217186637
64	HTG Mfg	634418217308632

Defendant Number	Store/Seller Name	Seller ID
65	HTG Suppliers	634418215823670
66	HUAMALL	634418212788176
67	HuangJiaConG	634418215584109
68	HuiYuan Boutique Shop	634418214707509
69	HXDZ	634418212399563
70	Improve our quality of Express delivery life	634418214853120
71	Intellectual childhood	5306483939571
72	JiaYueBaiHuo	634418211670589
73	Jin azure stone	634418216367818
74	Judy K	634418213988653
75	jun T	634418214609412
76	junjunliqing	634418212526107
77	Kellys cakes	634418212862267
78	KIIVmall	634418216709956
79	Kkitchenware	2755809516648
80	Kknowy	4189067804365
81	kspo	634418218165843
82	KUNYINGMAOYE	5685040985527
83	LAKING	4157761961162
84	Lao Lius Treasure Chest	634418214868801
85	Lconic	634418217433654
86	LEEN SHOP	634418214954252
87	Leohk	634418212868265
88	Leohkfive	634418218093342
89	Leohkfour	634418217614368
90	Leohkthree	634418216197326
91	LERYEE	634418214096227
92	LIDO FIRE	634418211906390
93	Longshaoxiaodian	3081492062223
94	Love leather bag	634418210963546
95	LT TXDY	634418214377422
96	Lu chun fishing gear	983947045087
97	Lucas Leu	634418211277734
98	Lucky lady MeiMei	634418216960516

Defendant Number	Store/Seller Name	Seller ID
99	LUXIAOER	634418215466217
100	Meijiajing Home furnishing	533930424574
101	MeKaren	22742859332
102	ML General Shop	634418216316155
103	MMegaMall	634418217371960
104	MOMOBRAS	634418214105784
105	More beautiful clothes	1219658487136
106	mountain top Q	634418213753816
107	Nancy stone	634418213400966
108	NatureNests	634418216954631
109	NetEBuy	634418211682814
110	New Number One	634418217877587
111	noem	634418211941559
112	Oilon	634418212557205
113	onloveeeee	5722573108891
114	Onlytu	5147854327363
115	OUR Various	634418216925423
116	People and Trojans	634418217446900
117	PHIPI SHOP	2792520256919
118	PICCI	634418212834057
119	Plus Size	35913910258
120	Preferably Zheheng	601099634135350
121	PureeHome	634418216649130
122	Q Y fashion	634418213280733
123	QAZ SUPPLY	634418216630031
124	quanchen best wishes	634418211921600
125	REDXHY	634418212174976
126	RMM Fashion	321653081388
127	Rose flowers	634418216223829
128	RUKEEY	634418216421585
129	SemiAssist Selections	635517729199895
130	Sexy Underwear T	22030692468
131	Sexygirlmm	634418218025252
132	SHENGYI Premium products	634418216939439

Defendant Number	Store/Seller Name	Seller ID
133	SHIJIKEJI	634418215657673
134	Shopift	634418217423735
135	Shops along the street	634418214367492
136	Shunxin YueGou	634418213469767
137	Smileplus Accessories	5937069577283
138	Song yi wang lu local	634418215435878
139	SunH	634418212520188
140	sweetie underpants	634418218314026
141	SWQONE	634418216646703
142	TAOTAOSHOP	4703968178720
143	TenCool	601099557960004
144	Tiantianhui	5009552186813
145	Ting D	634418218016985
146	TingS HOME	634418217288738
147	Top Perfect Mall	634418215534681
148	Topbooc	634418212464781
149	Topbooc Travels Luggage	634418212935544
150	Touchbra fou u	634418216980461
151	TPAT SHOP	634418214136923
152	TTomorrow	634418211211003
153	TuTu Magic House	1355789126743
154	TUZHIFEI	634418215481443
155	Umi Life Shop	634418216496346
156	UNIFIEDD	5952541346505
157	VALLEY	635517727758196
158	Various of shops	634418217711408
159	Veno	10736859393
160	VividVeil	634418217189332
161	wanggey	634418213978607
162	Warm Home f	634418211986790
163	WE CAN DUN	634418217189332
164	WERR	634418213978607
165	xiaoyapin	634418211986790
166	xuanse	634418216973030

Defendant Number	Store/Seller Name	Seller ID
167	XYZ Household Daily	634418217213323
168	Yan kang	634418216421497
169	YaXiu Underwear	634418213551243
170	YFF Lingerie	3547740787441
171	Yi Xiaomei	5537123062942
172	YingQiuDianZiShangWu	306865749424
173	yi y jia	634418214377692
174	YOCISIL	58368371348
175	YOHOY	35140078143
176	YoungGo	2609541841528
177	Your speed	634418214888682
178	Yugan Supplies	3241612839448
179	ZHANGFive	634418217513485
180	ZHANGsix	634418218099131
181	ZHANGthree	634418216219154
182	zhuanglu	634418214886305
183	ZM Socks	634418211091540
184	ZXZHANG	634418213613195
185	ZZHappy Trading	634418216950693

LISTING OF EXHIBITS

Exhibit 1Exemplar Screenshots of Infringing Listings









Exhibit 2.....Screenshots from Plaintiffs’ Website and Amazon Store

Exhibit 3.....U.S. Patent No. 8,152,591

Exhibit 4.....Comparison of Exemplar Infringing Product to claim 1 of U.S.
Patent No. 8,152,591

EXHIBIT 1

Example Infringing Listings

 <p>Instant layering... Control your style... Transform your look...</p>	 <p>Instant layering... Control your style... Transform your look...</p>
<p>Plaintiffs' Listing</p>	<p><i>Infringing Listing of Defendant Comfypro</i></p>
 <p>Instant layering... Control your style... Transform your look...</p>	 <p>Instant layering... Control your style... Transform your look...</p>
<p>Plaintiffs' Listing</p>	<p><i>Infringing Listing of Defendant Dewenbank</i></p>
 <p>Instant layering... Control your style... Transform your look...</p>	 <p>Instant layering... Control your style... Transform your look...</p>
<p>Plaintiffs' Listing</p>	<p><i>Infringing Listing of Defendant First</i></p>
 <p>Instant layering... Control your style... Transform your look...</p>	 <p>Instant layering... Control your style... Transform your look...</p>
<p>Plaintiffs' Listing</p>	<p><i>Infringing Listing of Defendant Top Perfect Mall</i></p>

 <p><i>Instant layering... Control your style... Transform your look...</i></p>	 <p><i>Instant layering... Control your style... Transform your look...</i></p>
<p>Plaintiffs' Listing</p>	<p><i>Infringing Listing of Defendant of VALLEY</i></p>
 <p><i>Instant layering... Control your style... Transform your look...</i></p>	 <p><i>Instant layering... Control your style... Transform your look...</i></p>
<p>Plaintiffs' Listing</p>	<p><i>Infringing Listing of Defendant of NatureNests</i></p>

EXHIBIT 2

https://www.cleava.com/category_s/1843.htm

The screenshot shows the Cleava website interface. At the top, there are navigation links: "HOME OF THE DAY", "BUY NOW", "EMAIL", "ABOUT US", "CONTACT US", and "WORK WITH US". The main content area features a comparison between "Cleava" and "Snappy Cami".

Cleava vs. Snappy Cami Comparison:

- Cleava (Left):** "Adjust here for the width of the bra strap and/or chest size." (Pointing to the top edge)
- Snappy Cami (Right):** "Adjust here for the width of the bra strap and/or chest size." (Pointing to the top edge)

VS.

Cleava (Bottom):

- "Adjust here for the width of the bra strap and/or chest size." (Pointing to the top edge)
- "Adjust here for the width of the bridge, cup size and height." (Pointing to the bridge area)
- A blue award ribbon: "BEST PRODUCT 2013"
- A circular seal: "100% PATENTED"

NEW!

Snappy Cami

Snap on Mock Camisole.
PATENTS • COPYRIGHTS • TRADEMARKS

Solid or Lace

Securely Snaps

Available in assorted colors and styles

Full lace worn over a solid = a variety of looks

**Instant layering...
Control your style...
Transform your look...**

BEFORE AFTER

Adjust here for the width of the bra strap and/or chest size.

Tuck under the bridge of the bra, or let it hang for deep low cut tops and dresses.

- Instantly On or Off. No need to undress.
- Covers cleavage in an elegant way.
- Fits most bras, thin to wide straps.
- Lightweight, cool and comfortable.

EXHIBIT 3



US008152591B2

(12) **United States Patent**
De Sousa et al.

(10) **Patent No.:** **US 8,152,591 B2**
(45) **Date of Patent:** **Apr. 10, 2012**

(54) **GARMENT AND BRASSIERE ACCESSORY**

(56) **References Cited**

(76) Inventors: **Michelle E. De Sousa**, Naples, FL (US);
Jose De Jesus De Sousa, Naples, FL (US)

U.S. PATENT DOCUMENTS

626,589	A *	6/1899	Bucher	450/28
731,759	A *	6/1903	Dieter	2/48
770,752	A *	9/1904	Hull	2/54
1,645,995	A *	10/1927	McCarthy	2/92
2,472,606	A *	6/1949	Michaelson	450/86
2,707,786	A *	5/1955	Stoner	2/119
3,064,265	A *	11/1962	Bridgewater	2/74
4,955,846	A	9/1990	Greenberg	
4,995,846	A *	2/1991	Mariol	446/376
6,205,585	B1 *	3/2001	Capparelli	2/106
6,550,067	B2 *	4/2003	Force	2/104
6,935,921	B1 *	8/2005	Eudenbach et al.	450/54
2006/0277648	A1 *	12/2006	Harry	2/69
2007/0281585	A1 *	12/2007	Calamari et al.	450/1

(*) Notice: Subject to any disclaimer, the term of this patent is extended or adjusted under 35 U.S.C. 154(b) by 0 days.

(21) Appl. No.: **13/095,124**

(22) Filed: **Apr. 27, 2011**

(65) **Prior Publication Data**

US 2011/0201251 A1 Aug. 18, 2011

Related U.S. Application Data

(63) Continuation of application No. 12/778,212, filed on May 12, 2010, which is a continuation-in-part of application No. 12/586,622, filed on Sep. 25, 2009, now Pat. No. 8,062,093, which is a continuation-in-part of application No. 11/855,131, filed on Sep. 13, 2007, now abandoned.

(51) **Int. Cl.**
A41C 3/00 (2006.01)

(52) **U.S. Cl.** **450/1; 450/30; 450/86; 2/105; 2/106**

(58) **Field of Classification Search** 450/1, 30-35, 450/63, 70-74, 77-80, 82, 86, 88, 87, 92, 450/93; 2/912, 913, 69, 73-75, 90, 96, 102-106, 2/109, 110, 113, 114, 118, 67, 119, 122, 2/129, 133, 46, 50-54

See application file for complete search history.

* cited by examiner

Primary Examiner — Gloria Hale

(74) *Attorney, Agent, or Firm* — Maier & Maier, PLLC

(57) **ABSTRACT**

A garment and brassiere accessory that is substantially triangular in shape having attachment straps extending outward from upper corners of the undergarment that may be looped around shoulder straps of a brassiere. In addition, a lower corner may be looped around a center portion of the brassiere. An upper band of preferably elastomeric material located along an upper edge of the undergarment keeps the undergarment securely against a woman's chest while being worn. The undergarment is preferably constructed from two layers of material, an outer layer and an inner layer so that the outer layer hides any wrinkles or indentations caused by the stress of the lower corner pulling on the inner layer while the undergarment is being worn. Additional features include extension straps that allow a user to adapt the undergarment to a larger chest and/or brassiere size or to wear the undergarment without a brassiere and detachable jewelry.

20 Claims, 4 Drawing Sheets

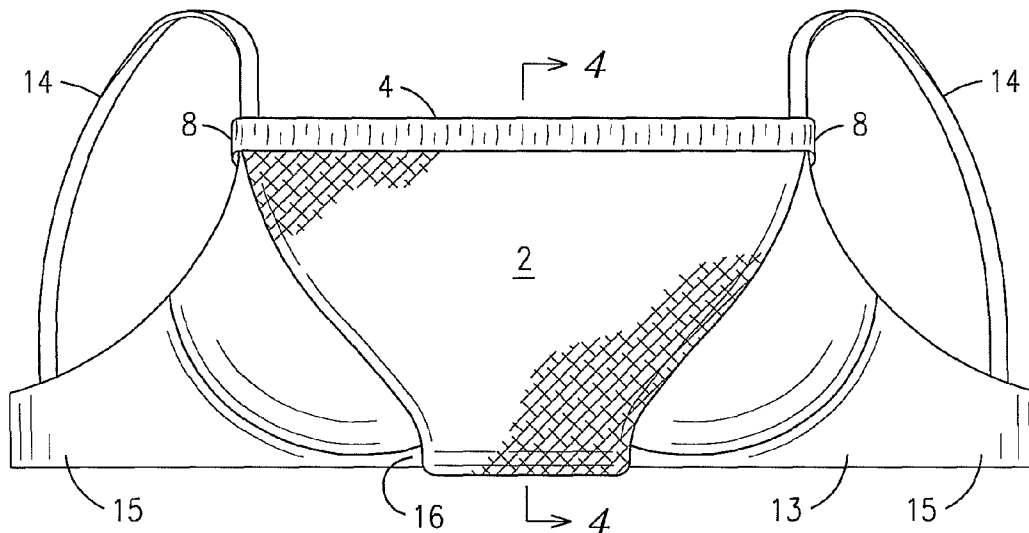

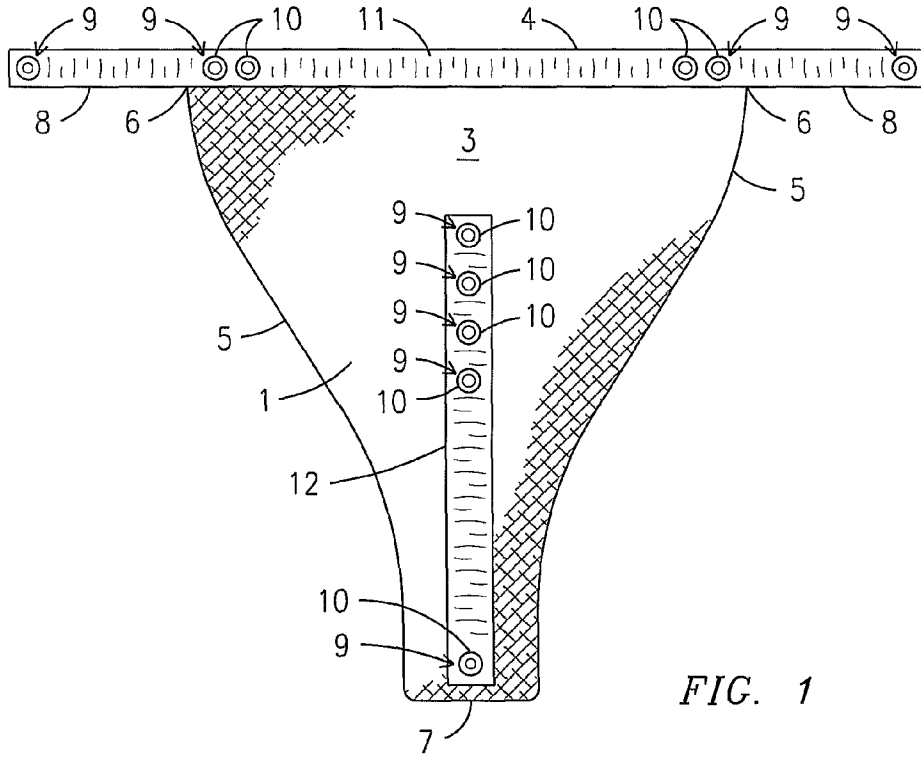

FIG. 1

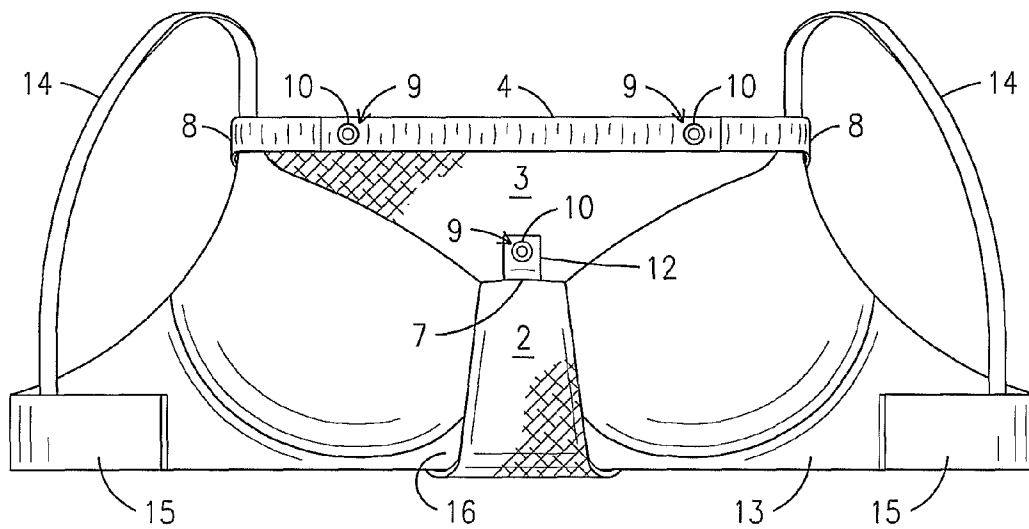

FIG. 2

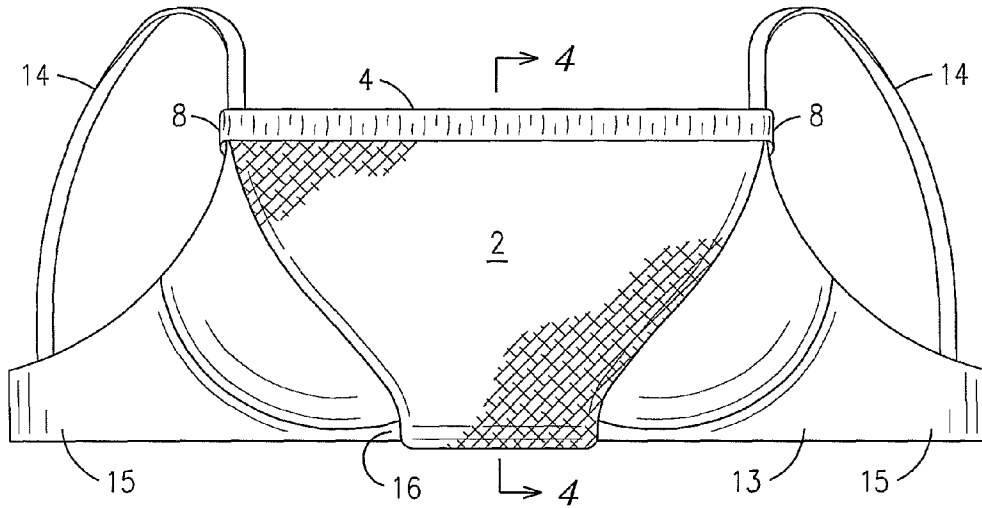

FIG. 3

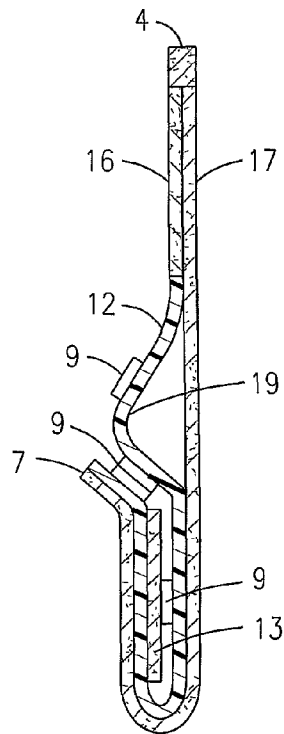

FIG. 4

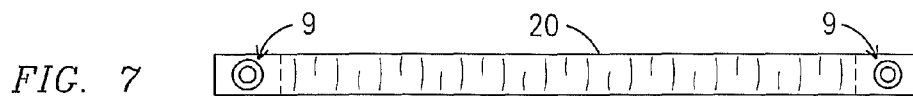

FIG. 7

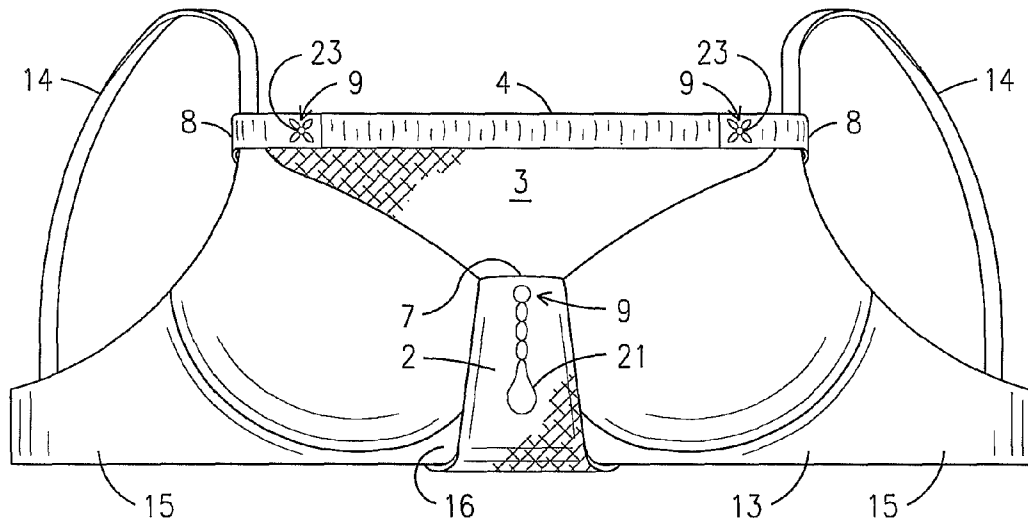

FIG. 5

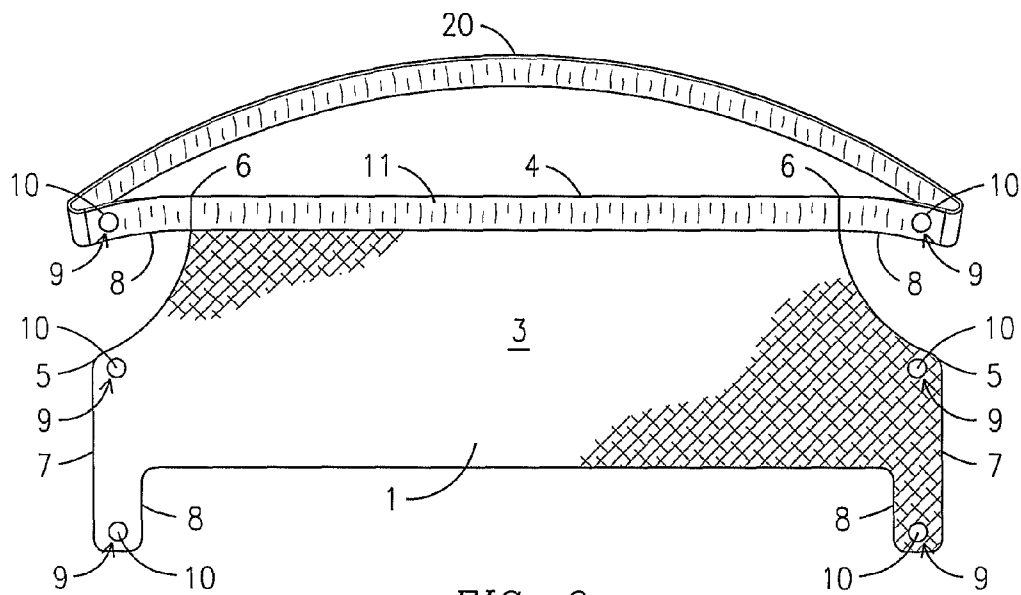

FIG. 6

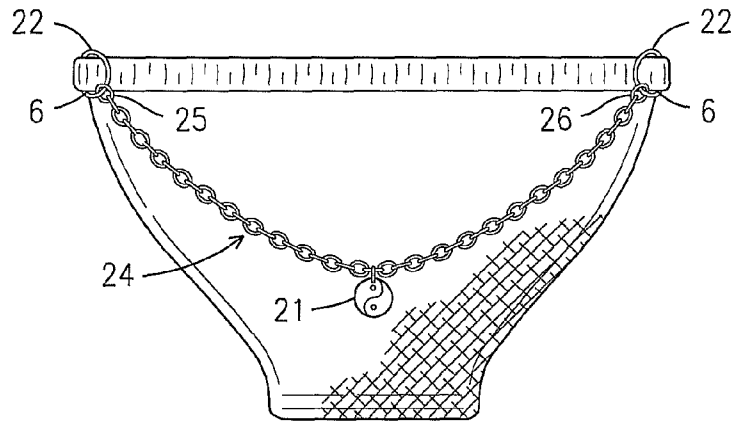

FIG. 8

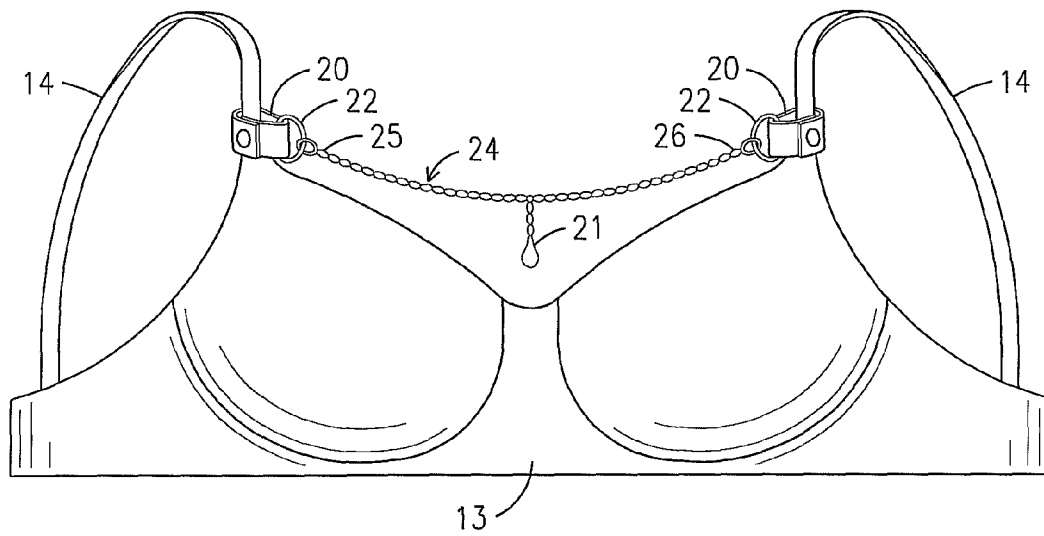

FIG. 9

GARMENT AND BRASSIERE ACCESSORY

CROSS REFERENCE TO RELATED APPLICATION

This is a continuation application of U.S. patent application Ser. No. 12/778,212, filed on May 12, 2010, which was a continuation-in-part application of U.S. patent application Ser. No. 12/586,622, filed on Sep. 25, 2009, which was a continuation-in-part application of U.S. patent application Ser. No. 11/855,131, filed on Sep. 13, 2007. The patent applications identified above are incorporated hereby in their entirety to provide continuity of disclosure.

BACKGROUND OF THE INVENTION

This invention relates to women's garments, undergarments and brassieres, more particularly, a device that attaches to a brassiere and simulates a camisole or tank top and covers a user's chest area and/or cleavage, thereby allowing the user to wear short-cut tops and dresses in formal or any other situations that require a modest attire.

There are many environments, such as work, school, church, etc., where it is considered inappropriate for women to wear low short-cut tops or dresses that reveal too much cleavage. Many women own dresses and/or tops that are formal, but low cut. Therefore a woman can be very limited in her options with regard to clothes for work and so forth. Past attempts have been made to develop garments that attach to brassieres or prevent the low cut tops or dresses to cover exposed cleavage.

However, many of these garments do not attach securely to brassieres to ensure that the garments will not come loose and also do not fit snugly against a woman's chest. A further problem with past garments is that they are not adjustable and thus are not adaptable to different chest sizes and/or different sizes of brassieres. An even further problem with past garments is that some use securing means, such as adhesives, strings, bows, etc., to attach the garments to the brassiere or to the outer garment. These past securing means have been prone to failure due to the fact that securing means, such as adhesives, do not always adhere and do not allow a user to re-use the garment without applying new adhesive. Further, securing means, such as bows, show through the outer garment, thereby making it obvious that a woman is wearing a cleavage covering device that simulates a tank top or camisole. An even further problem with past devices is that they do not attach to strapless brassieres.

Therefore, a need exists for an undergarment that securely attaches to a wearers brassiere, is adjustable to a woman's chest and/or bra size, gives the appearance of being an actual undergarment such as a tank-top, provides a re-usable securing means and can be worn even without a brassiere.

The relevant prior art includes the following references:

Pat. No. (u.s. unless stated otherwise)	Inventor	Issue/Publication Date
2007/0281585	Calamari et al.	Dec. 06, 2007
4,955,846	Greenberg	Sep. 11, 1990

SUMMARY OF THE INVENTION

The primary object of the present invention are to provide a garment and brassiere accessory that securely attaches to a wearer's brassiere.

Another object of the present invention is to provide a garment and brassiere accessory that is adjustable to a woman's chest and/or bra size.

5 An even further object of the present invention is to provide a garment and brassiere accessory that gives the appearance of being an actual undergarment, such as a tank top.

Another object of the present invention is to provide a garment and brassiere accessory that provides a re-usable securing means.

10 An even further object of the present invention is to provide a garment and brassiere accessory that provides a securing means that is not visible through an outer garment.

15 Another object of the present invention is to provide a garment and brassiere accessory that fits securely against a woman's chest.

An even further object of the present invention is to provide a garment and brassiere accessory that will attach to a strapless brassiere.

20 An additional object of the present invention is to provide a garment and brassiere accessory that allows attachment of jewelry to the garment.

25 An even further object of the present invention is to provide a garment and brassiere accessory that can be instantly taken on or off.

An additional object of the present invention is to provide a garment and brassiere accessory that can be worn without a brassiere.

30 The present invention fulfills the above and other objects by providing a garment and brassiere accessory that is substantially triangular in shape having a front surface, a rear surface, an upper edge, side edges, upper corners and a lower corner. Attachment straps extend outward from the upper corners. The attachment straps may be looped around the shoulder straps of a brassiere or in the case of a strapless brassiere, around the side straps of the brassiere. The attachment straps have securing means, such as snaps, buttons, hook and loop fastener, etc., located thereon. After looping the attachment straps around the shoulder straps of a brassiere, the securing means located on the attachment straps are secured to a corresponding securing means located along the upper edge of the garment and brassiere accessory. There may be a plurality of securing means located along the upper edge to allow a user to adjust the length of the loops made by the attachment straps and, thus, the width of the garment and brassiere accessory. A securing means is also located on the lower corner of the device. The lower corner may be looped around the center portion of a brassiere. After looping the lower corner around the center portion of a brassiere, the securing means located on the lower corner is secured to a corresponding securing means located on the rear side of the garment and brassiere accessory.

35 There may be a plurality of securing means located on the rear side of the garment and brassiere accessory to allow a user to adjust the length of the loop made by the lower corner and, thus, the height of the garment and brassiere accessory.

40 An upper band of elastomeric material is located along the upper edge of the garment and brassiere accessory. The elastomeric material keeps the garment and brassiere accessory securely against a woman's chest while being worn. The garment and brassiere accessory is preferably constructed from two layers of material, an outer layer and an inner layer. An advantage of having multiple layers of material is that the outer layer hides the securing means as well as any wrinkles or indentations caused by the stress of the lower corner pulling on the inner layer while the garment and brassiere accessory is being worn.

Additional features of the present invention include extension straps that attach to the attachment straps and allow a user to adapt the garment and brassiere accessory to a larger chest and/or brassiere size. The extension straps may also be used so that a woman can still wear the garment and brassiere accessory without a brassiere. For example, a long extension strap that goes around the woman's back may be attached to the attachment straps of the garment and brassiere accessory. The garment and brassiere accessory may also include attachment means for attaching jewelry to the garment. The above and other objects, features and advantages of the present invention should become even more readily apparent to those skilled in the art upon a reading of the following detailed description in conjunction with the drawings wherein there is shown and described illustrative embodiments of the invention.

BRIEF DESCRIPTION OF THE DRAWINGS

In the following detailed description, reference will be made to the attached drawings in which:

FIG. 1 is a rear view of a garment and brassiere accessory of the present invention;

FIG. 2 is a rear view of a garment and brassiere accessory of the present invention attached to a brassiere;

FIG. 3 is a front view of a garment and brassiere accessory of the present invention attached to a brassiere;

FIG. 4 is a side cross sectional view along line 4-4 of FIG. 3 of a garment and brassiere accessory of the present invention attached to a brassiere;

FIG. 5 is a front view of a garment and brassiere accessory of the present invention attached to a bikini top;

FIG. 6 is a front view of a garment and brassiere accessory of the present invention for use with strapless brassieres;

FIG. 7 is a rear view of an extension strap of the present invention;

FIG. 8 is a front view of a garment and brassiere accessory of the present invention having jewelry attached thereto; and

FIG. 9 is a front view of a brassiere having jewelry attached thereto via extension straps of the present invention.

DESCRIPTION OF THE PREFERRED EMBODIMENTS

For purposes of describing the preferred embodiment, the terminology used in reference to the numbered components in the drawings is as follows:

1. body
2. front surface
3. rear surface
4. upper edge
5. side edge
6. upper corner
7. lower corner
8. attachment strap
9. securing means
10. snap
11. upper band
12. lower band
13. brassiere
14. shoulder straps
15. side straps
16. center portion
17. outer layer
18. inner layer
19. indentation
20. extension strap

21. jewelry
22. attachment means
23. bikini top
24. linking means
25. first end
26. second end

With reference to FIG. 1, a rear view of a garment and brassiere accessory of the present invention is shown. The garment and brassiere accessory comprises a body 1 that is substantially triangular in shape. The body 1 comprises a front surface 2 (as shown in FIG. 3), a rear surface 3, an upper edge 4, side edges 5, upper corners 6 and a lower corner 7. Attachment straps 8 extend outward from the upper corners 6. A plurality of securing means 9, such as snaps 10, buttons, hook and loop fasteners, hook and eye fasteners, etc., are located along the upper edge 4 of the garment and brassiere accessory and attachment straps 8. Also, a securing means 9 is also located on the lower corner 7 of the garment and brassiere accessory. In addition, a plurality of securing means 9 are located on the rear surface 3 of the garment and brassiere accessory directly above the lower corner 7. An upper band 11 preferably having elastomeric qualities is located along the upper edge 4 of the garment and brassiere accessory. The upper band 11 keeps the garment and brassiere accessory securely against a woman's chest while being worn. A lower band 12 preferably having elastomeric qualities is located on the rear surface 3 of the garment and brassiere accessory and provides reinforcement for the securing means 9 that are located on the rear surface 3 of the garment and brassiere accessory directly above the lower corner 7.

With reference to FIGS. 2 and 3, a rear view and a front view of a garment and brassiere accessory of the present invention attached to a brassiere 13, respectively, are shown. To secure the garment and brassiere accessory to a brassiere 13, the attachment straps 8 are looped around shoulder straps 14 of the brassiere 13 or in the case of a strapless brassiere, looped around or looped under and over side straps 15 of the brassiere 13. The attachment straps 8 are then secured to the upper edge 4 of the garment and brassiere accessory by attaching the securing means 9 located on the attachment straps 8, which as shown here are snaps 10, to corresponding securing means 9 located along the upper edge 4 of the garment and brassiere accessory. Then the lower corner 7 is looped around a center portion 16 of the brassiere 13. The lower corner 7 is then secured to the rear surface 3 of the garment and brassiere accessory by attaching the securing means 9 located on the lower corner 7 to corresponding securing means 9 located along the rear surface 3 of the garment and brassiere accessory.

With reference to FIG. 4, a side cross sectional view along line 4-4 of FIG. 3 of a garment and brassiere accessory of the present invention attached to a brassiere 13 is shown. The garment and brassiere accessory is preferably constructed from two layers of material, an outer layer 17 and an inner layer 18, both preferably made of a stretchable cloth-like material. An advantage of having an outer layer 17 and an inner layer 18 is that the outer layer 17 hides the securing means 9 as well as any wrinkles or indentations 19 caused by the stress of the lower corner 7 pulling downward on the inner layer 17 while the garment and brassiere accessory is being worn.

With reference to FIG. 5, a front view of a garment and brassiere accessory of the present invention attached to a bikini top 23 is shown. The garment and brassiere accessory is worn with the rear surface 3 facing outward when worn on a bikini top 23. To secure the garment and brassiere accessory to the bikini top 23, the attachment straps 8 are looped around

5

shoulder straps **14** of the bikini top **23**. The attachment straps **8** are then secured to the upper edge **4** of the garment and brassiere accessory by attaching the securing means **9** located on the attachment straps **8**, which as shown here are decorative snaps **23**, to corresponding securing means **9** located along the upper edge **4** of the garment and brassiere accessory. Then the lower corner **7** is looped around a center portion **16** of the bikini top **23**. The lower corner **7** is then secured to the rear surface **3** of the garment and brassiere accessory by attaching the securing means **9** located on the lower corner **7** to corresponding securing means **9** located along the rear surface **3** of the garment and brassiere accessory. A decorative piece of jewelry **21** is attached to the securing means **9** located on the lower corner **7**.

With reference to FIG. 6, a front view of a garment and brassiere accessory of the present invention for use with strapless brassieres. The garment and brassiere accessory comprises a body **1** that is substantially rectangular in shape. The body **1** comprises a front surface **2**, a rear surface **3**, an upper edge **4**, side edges **5**, upper corners **6** and lower corners **7**. Attachment straps **8** extend outward from the upper corners **6**. Securing means **9**, such as snaps **10**, buttons, hook and loop fasteners, hook and eye fasteners, etc., are located on the attachment straps **8**. The attachment straps **8** are used in conjunction with an extension strap **20** (as shown further in FIG. 7) that allows a user to secure the upper edge **4** of the garment and brassiere accessory around the user's back. Also, attachment straps **8** having securing means **9** extend downward from the lower corners **7** of the garment and brassiere accessory. In addition, securing means **9** are located on the rear surface **3** of the garment directly above the lower corners **7**. The attachment straps **8** located on the lower corners **7** may be looped around or looped under and over side straps **15** of the brassiere **13**. An upper band **11** preferably having elastomeric qualities is located along the upper edge **4** of the garment and brassiere accessory. The upper band **11** keeps the garment and brassiere accessory securely against a woman's chest while being worn.

With reference to FIG. 7, a rear view of an extension strap **20** of the present invention **20** is shown. The extension strap **20** can be made in various lengths or sizes. The extension strap **20** has securing means **9** located on opposite ends that attach to the securing means **9** located on the garment and brassiere accessory allow a user to adapt the garment and brassiere accessory to a larger chest and/or brassiere **13** size. Extension straps **20** may also be used so that a woman can still wear the garment and brassiere accessory without a brassiere **13**. For example, a long extension strap **20** may be attached to the attachment straps **8** of the garment and brassiere accessory and be worn around the back of a user.

With reference to FIG. 8, a front view of a garment and brassiere accessory of the present invention having jewelry **21** attached thereto is shown. The garment and brassiere accessory may have an attachment means **22**, such as loops, hooks, clasps, etc., that allow a user to attach a piece of jewelry **21** or a plurality of linking means **24**, such as a rope, ribbon, wire, chain, pearls, beads, etc., having a first end **25** and a second end **26**, to the garment and brassiere accessory or directly to a brassiere. The attachment means **22** are preferably located near the upper corners **6** of the garment and brassiere accessory.

Finally with reference to FIG. 9, a front view of a brassiere **13** having jewelry **21** attached thereto via extension straps **20** of the present invention is shown. Jewelry **21** or a plurality of linking means **24**, such as a rope, ribbon, wire, chain, pearls, beads, etc., having a first end **25** and a second end **26**, is attached to the brassiere **13** by looping the extension straps **20** around the shoulder straps **14** of the brassiere **13** and through the an attachment means **22**, which as shown here are rings.

6

It is to be understood that while a preferred embodiment of the invention is illustrated, it is not to be limited to the specific form or arrangement of parts herein described and shown. It will be apparent to those skilled in the art that various changes may be made without departing from the scope of the invention and the invention is not to be considered limited to what is shown and described in the specification and drawings.

What is claimed is:

1. A brassiere garment accessory comprising:

a body having a front surface,
a rear surface,
an upper edge,
at least two side edges, and
at least two upper corners at distal ends of the upper edge
and at least one lower corner;
at least one attachment strap extending from each of the at least two upper corners, the at least one attachment strap having a proximal portion coupled to the body and a distal portion extending away from the body along the upper edge; and
at least one fastener located on the distal portion of the at least one attachment strap that facilitates coupling of the at least one fastener located on the distal portion of the at least one attachment strap to at least one fastener located on at least one of the proximal portion of the at least one attachment strap and the body of the brassiere garment accessory.

2. A brassiere garment accessory of claim **1** further comprising: an upper band located along the upper edge of the body.

3. A brassiere garment accessory of claim **2** wherein: said upper band has elastomeric qualities.

4. A brassiere garment accessory of claim **1** further comprising: a lower band located on the rear surface of the body.

5. A brassiere garment accessory of claim **2** wherein: said lower band has elastomeric qualities.

6. A brassiere garment accessory of claim **1** wherein: the body further comprises at least one outer layer and at least one inner layer.

7. A brassiere garment accessory of claim **1** further comprising: an extension strap for extending the length of the at least one attachment strap.

8. A brassiere garment accessory of claim **1** further comprising: an attachment portion for attaching a piece of jewelry to the garment and brassiere accessory.

9. A brassiere garment accessory of claim **1** wherein: the body further comprises at least one lower corner.

10. A brassiere garment accessory of claim **9** further comprising: at least one fastener located on the at least one lower corner.

11. A brassiere garment accessory comprising:

a body having a front surface, a rear surface, an upper edge,
at least two side edges, and at least two upper corners at distal ends of the upper edge;
at least one attachment strap extending from each of the at least two upper corners, the attachment strap having a proximal portion coupled to the body and a distal portion extending away from the body along the upper edge; and
at least one fastener located on the distal portion of the attachment strap that facilitates coupling of the at least one fastener located on the distal portion of the at least one attachment strap to at least one fastener located on at least one of the proximal portion of the at least one attachment strap and the body of the brassiere garment accessory; wherein at least a portion of the body comprises at least one inner layer and at least one outer layer; and the upper edge has elastomeric qualities.

12. A brassiere garment accessory of claim **11** further comprising: an upper band located along the upper edge of the body.

7

13. A brassiere garment accessory of claim 12 wherein: said upper band has elastomeric qualities.

14. A brassiere garment accessory of claim 11 further comprising: a lower band located on the rear surface of the body.

15. A brassiere garment accessory of claim 14 wherein: 5
said lower band has elastomeric qualities.

16. A brassiere garment accessory of claim 11 further comprising: an extension strap for extending the length of the at least one attachment strap.

17. A brassiere garment accessory of claim 11 further comprising: an attachment portion for attaching a piece of jewelry 10
to the garment and brassiere accessory.

18. A brassiere garment accessory comprising:

a body having a front surface, a rear surface, an upper edge, 15
at least two side edges, and at least two upper corners at distal ends of the upper edge and at least one lower corner;

and

at least one attachment strap extending from each of the at least two side edges, the attachment strap having a proxi-

8

mal portion coupled to the body and a distal portion extending away from the body along the upper edge the at least one attachment strap further having at least one fastener located on a distal portion of the at least one attachment strap that facilitates coupling of the at least one fastener located on the distal portion of the at least one attachment strap to at least one fastener located on at least one of a proximal portion of the at least one attachment strap and the body of the brassiere garment accessory.

19. A brassiere garment accessory of claim 18, wherein at least a portion of the body comprises at least one inner layer and at least one outer layer.

20. A brassiere garment accessory of claim 18, further comprising a plurality of fasteners located on the proximal portion of the attachment strap and at least one fastener located on the distal portion of the attachment strap.

* * * * *

EXHIBIT 4

Claim Chart

US Patent No. 8152591

Claim 1

1. A brassiere garment accessory comprising:

a body having a front Surface, a rear Surface, an upper edge,

at least two side edges,

and at least two upper corners at distal ends of the upper edge and at least one lower corner,

at least one attachment strap extending from each of the at least two upper corners,

the at least one attachment strap having a proximal portion coupled to the body and a distal portion extending away from the body along the upper edge;

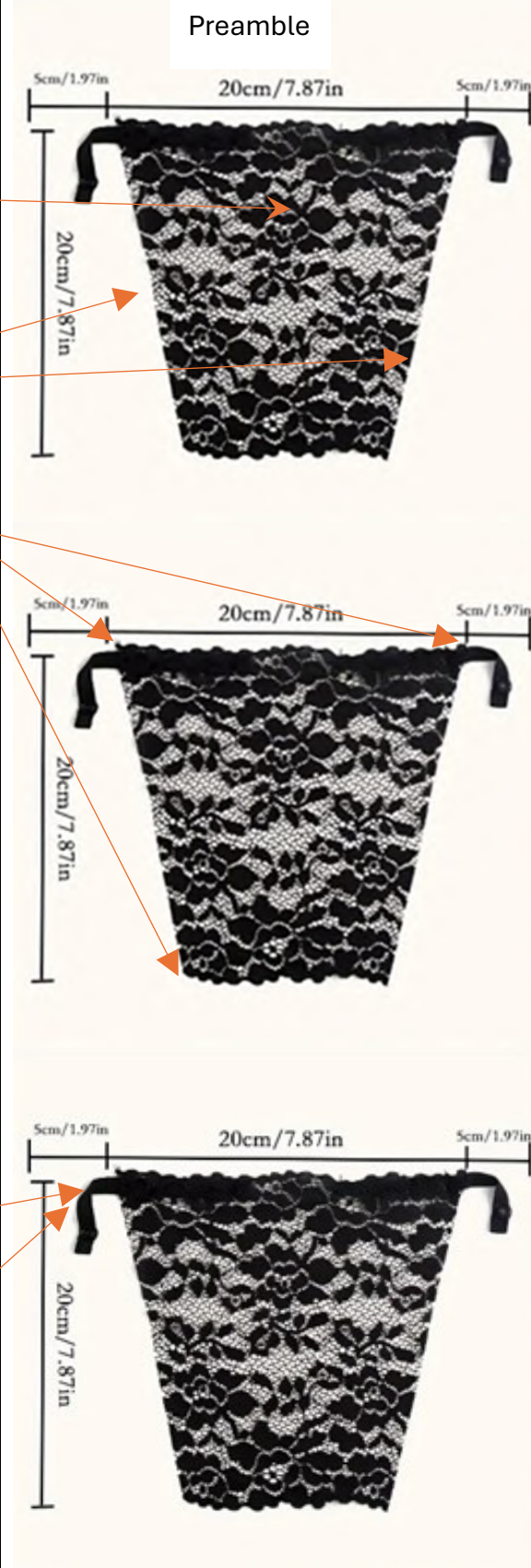

and at least one fastener located on the distal portion of the at least one attachment strap that facilitates coupling of the at least one fastener located on the distal portion of the at least one attachment strap to at least one fastener located on at least one of the proximal portion of the at least one attachment strap and the body of the brassiere garment accessory.

